

ECEN 4618
Advanced Electronics Lab
Spring 1999
Quiz # 4

Name: SOLUTION

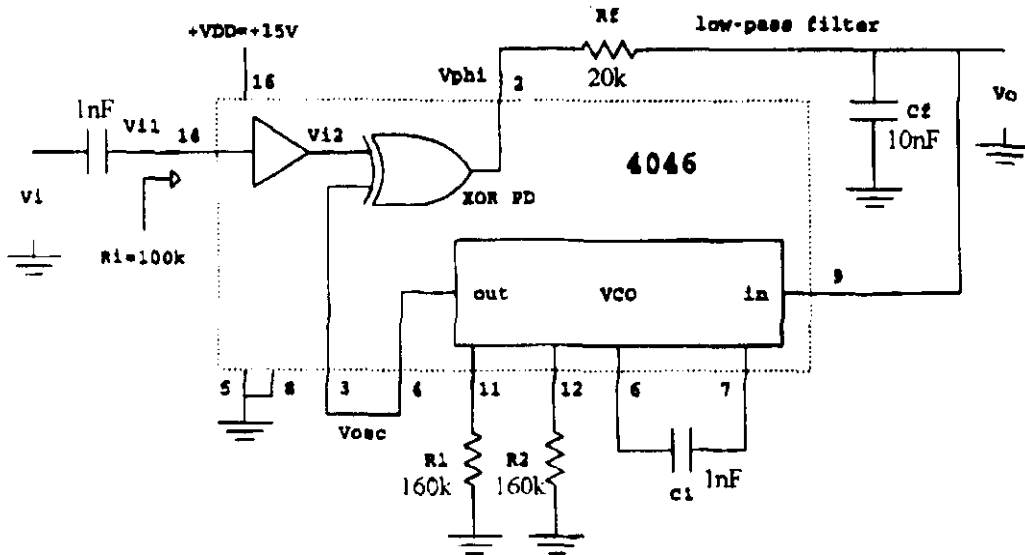

For the CMOS 4046 PLL circuit shown above, and using the theoretical equations outlined in the Lab 4 handout, find:

(1 point) The minimum output frequency of the VCO, f_{min} : $f_{min} \approx 6 \text{ KHz}$

(1 point) The maximum output frequency of the VCO, f_{max} : $f_{max} \approx 12 \text{ KHz}$

(1 point) The gain of the VCO, K_o : (make sure to include the units of K_o in your answer)

$$K_o \approx 400 \text{ Hz/V}$$

(1 point) The cutoff frequency of the low-pass loop filter, f_p :

$$f_p \approx 800 \text{ Hz}$$

(3 points) What is the free running frequency, f_o , of this PLL?

$$f_o = \frac{f_{min} + f_{max}}{2} \approx 9 \text{ KHz}$$

(3 points) True or False: "If the filter capacitance C_f is increased, the **capture range** will also increase."

$$2f_c \approx \sqrt{2K_o f_p V_{DD}} \quad ; \quad f_p = \frac{1}{2\pi R C_f}$$

IF $C_f \uparrow$, THEN $f_p \downarrow$ AND $f_c \downarrow$, SO FALSE