

Chapter 2

Principles of Steady-State Converter Analysis

- 2.1. Introduction
- 2.2. Inductor volt-second balance, capacitor charge balance, and the small ripple approximation
- 2.3. Boost converter example
- 2.4. Cuk converter example
- 2.5. Estimating the ripple in converters containing two-pole low-pass filters
- 2.6. Summary of key points

2.1 Introduction

Buck converter

SPDT switch changes dc component

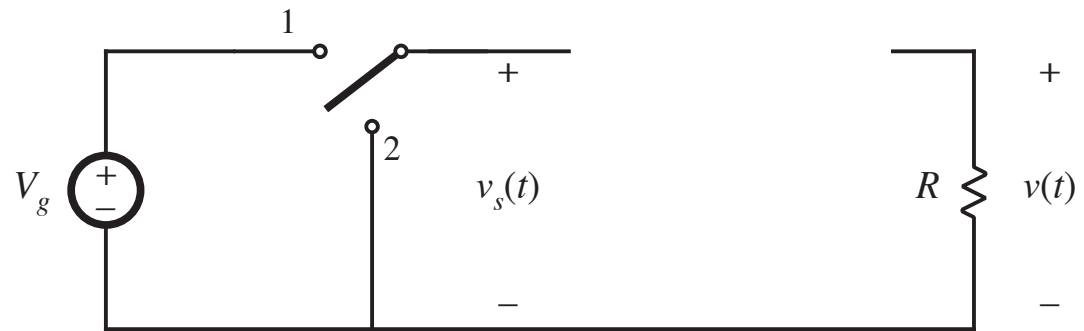

Switch output voltage waveform

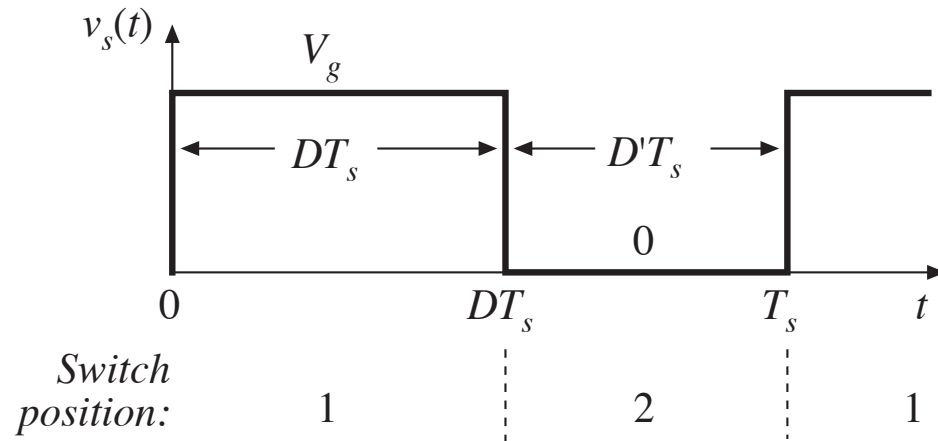

Duty cycle D :
 $0 \leq D \leq 1$

complement D' :
 $D' = 1 - D$

Dc component of switch output voltage

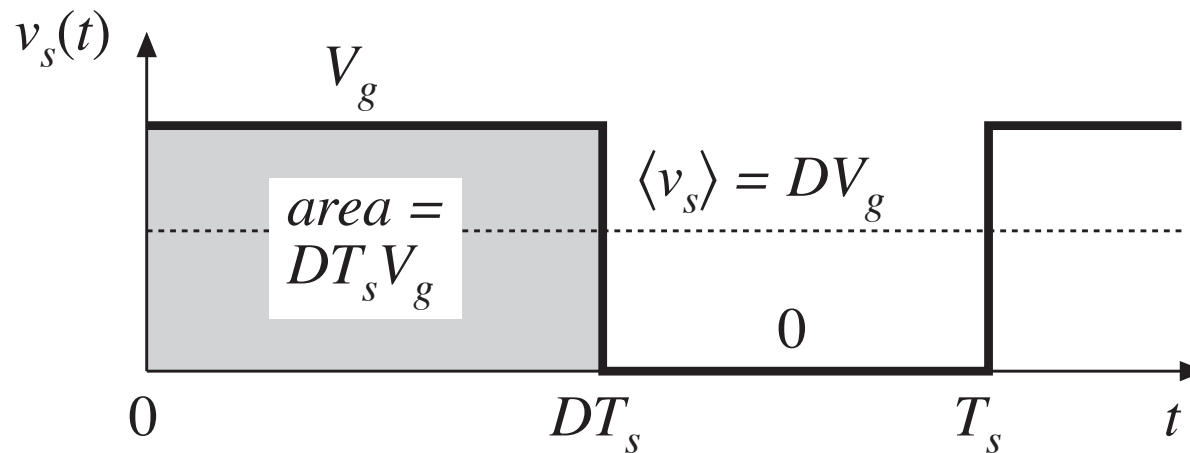

Fourier analysis: Dc component = average value

$$\langle v_s \rangle = \frac{1}{T_s} \int_0^{T_s} v_s(t) dt$$

$$\langle v_s \rangle = \frac{1}{T_s} (DT_s V_g) = DV_g$$

Insertion of low-pass filter to remove switching harmonics and pass only dc component

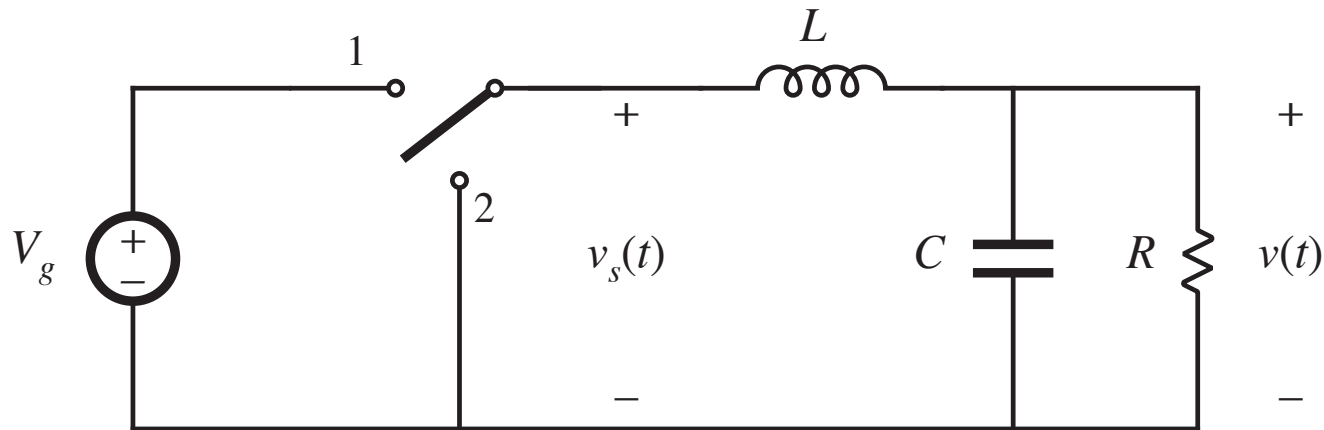

$$v \approx \langle v_s \rangle = DV_g$$

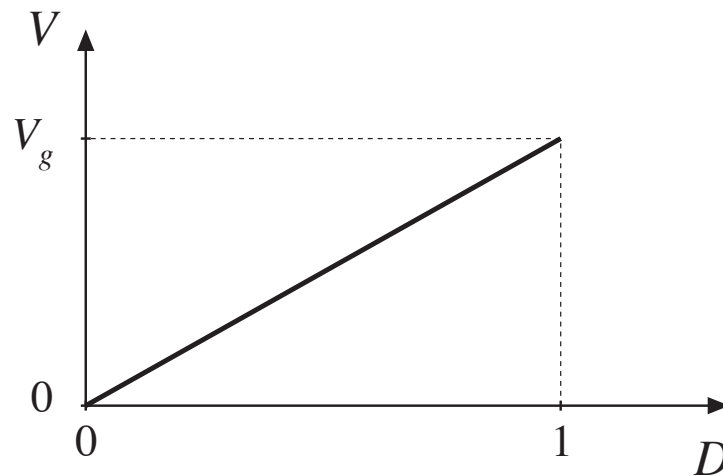

Three basic dc-dc converters

Buck

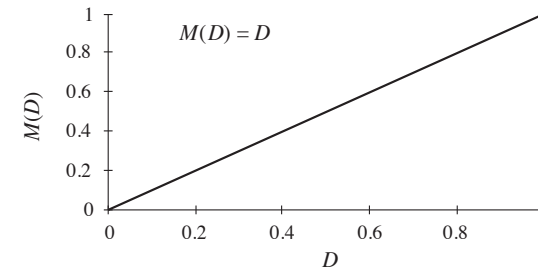
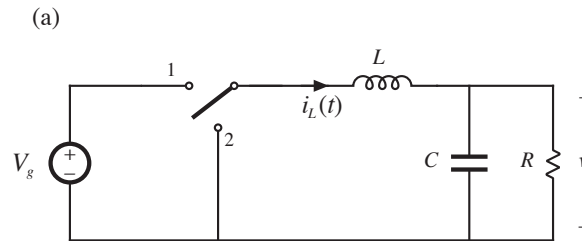

Boost

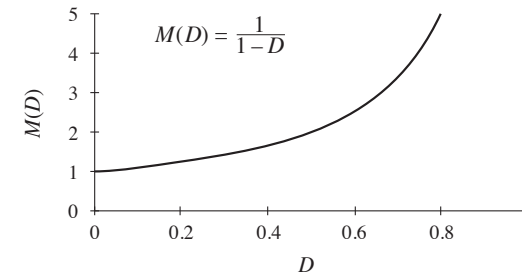
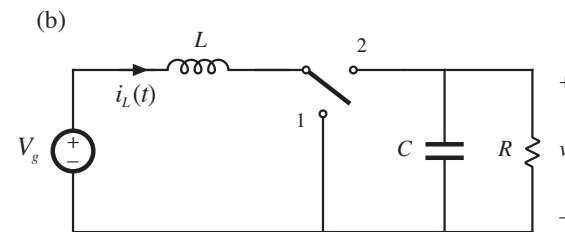

Buck-boost

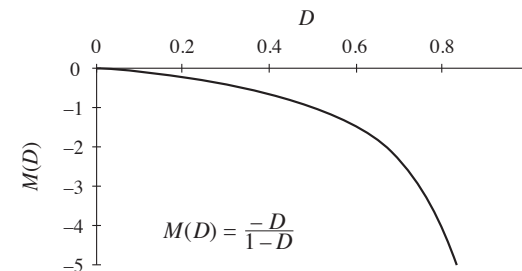
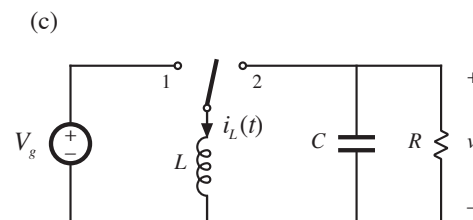

Objectives of this chapter

- Develop techniques for easily determining output voltage of an arbitrary converter circuit
- Derive the principles of *inductor volt-second balance* and *capacitor charge (amp-second) balance*
- Introduce the key *small ripple approximation*
- Develop simple methods for selecting filter element values
- Illustrate via examples

2.2. Inductor volt-second balance, capacitor charge balance, and the small ripple approximation

Actual output voltage waveform, buck converter

*Buck converter
containing practical
low-pass filter*

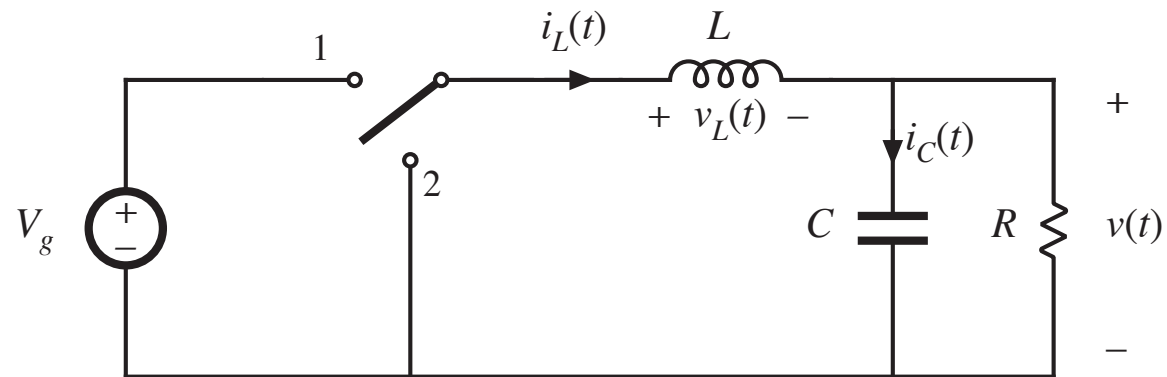

*Actual output voltage
waveform*

$$v(t) = V + v_{\text{ripple}}(t)$$

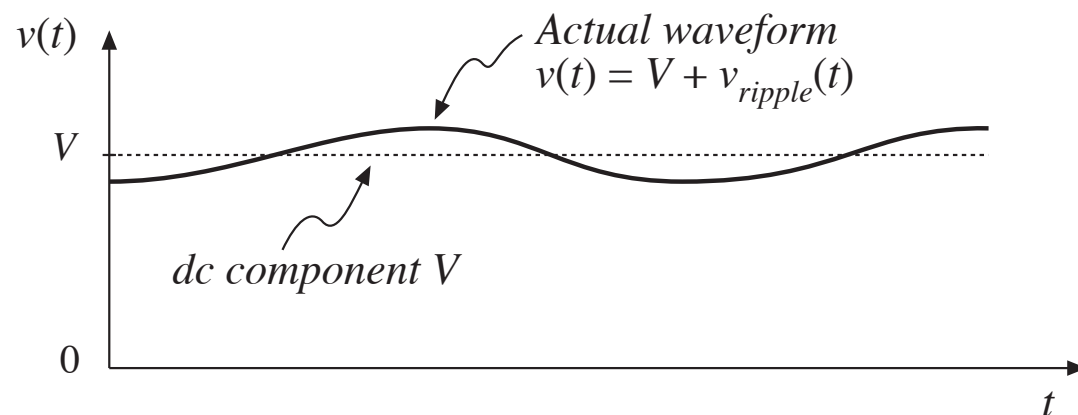

The small ripple approximation

$$v(t) = V + v_{ripple}(t)$$

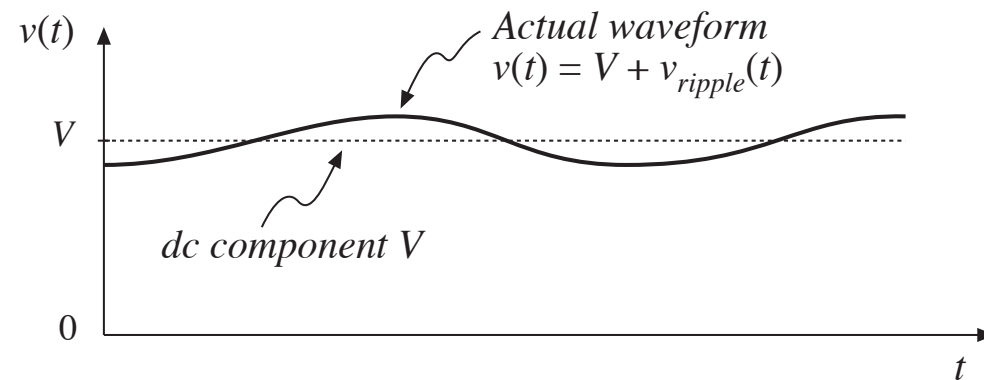

In a well-designed converter, the output voltage ripple is small. Hence, the waveforms can be easily determined by ignoring the ripple:

$$\|v_{ripple}\| < V$$

$$v(t) \approx V$$

Buck converter analysis: inductor current waveform

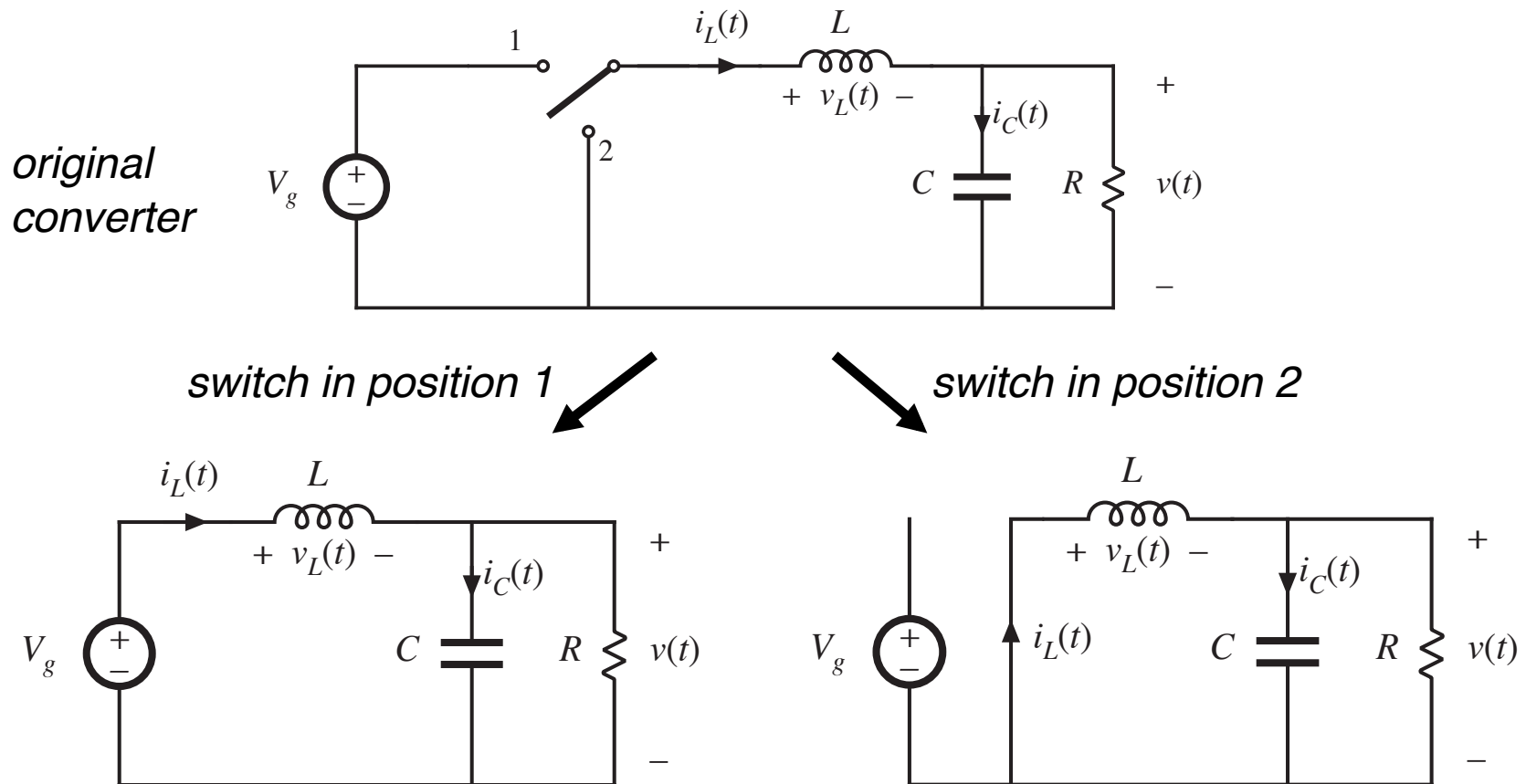

Inductor voltage and current

Subinterval 1: switch in position 1

Inductor voltage

$$v_L = V_g - v(t)$$

Small ripple approximation:

$$v_L \approx V_g - V$$

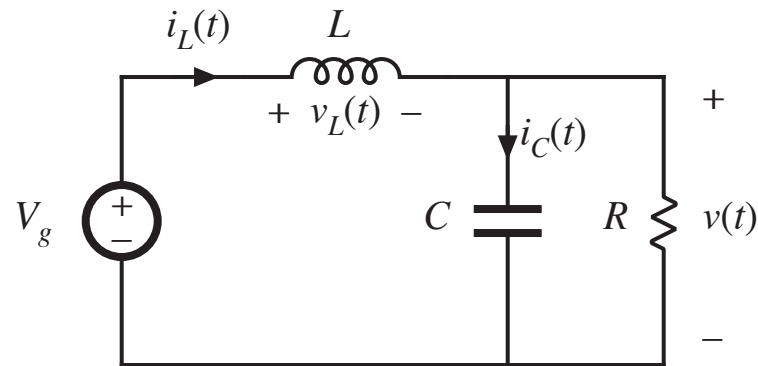

Knowing the inductor voltage, we can now find the inductor current via

$$v_L(t) = L \frac{di_L(t)}{dt}$$

Solve for the slope:

$$\frac{di_L(t)}{dt} = \frac{v_L(t)}{L} \approx \frac{V_g - V}{L}$$

\Rightarrow *The inductor current changes with an essentially constant slope*

Inductor voltage and current

Subinterval 2: switch in position 2

Inductor voltage

$$v_L(t) = -v(t)$$

Small ripple approximation:

$$v_L(t) \approx -V$$

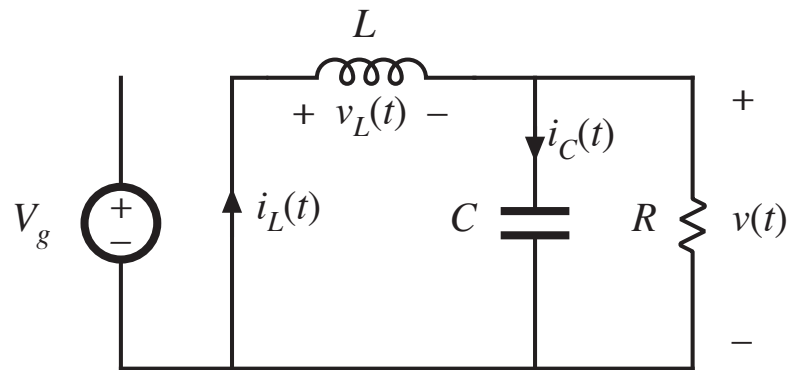

Knowing the inductor voltage, we can again find the inductor current via

$$v_L(t) = L \frac{di_L(t)}{dt}$$

Solve for the slope:

$$\frac{di_L(t)}{dt} \approx -\frac{V}{L}$$

\Rightarrow *The inductor current changes with an essentially constant slope*

Inductor voltage and current waveforms

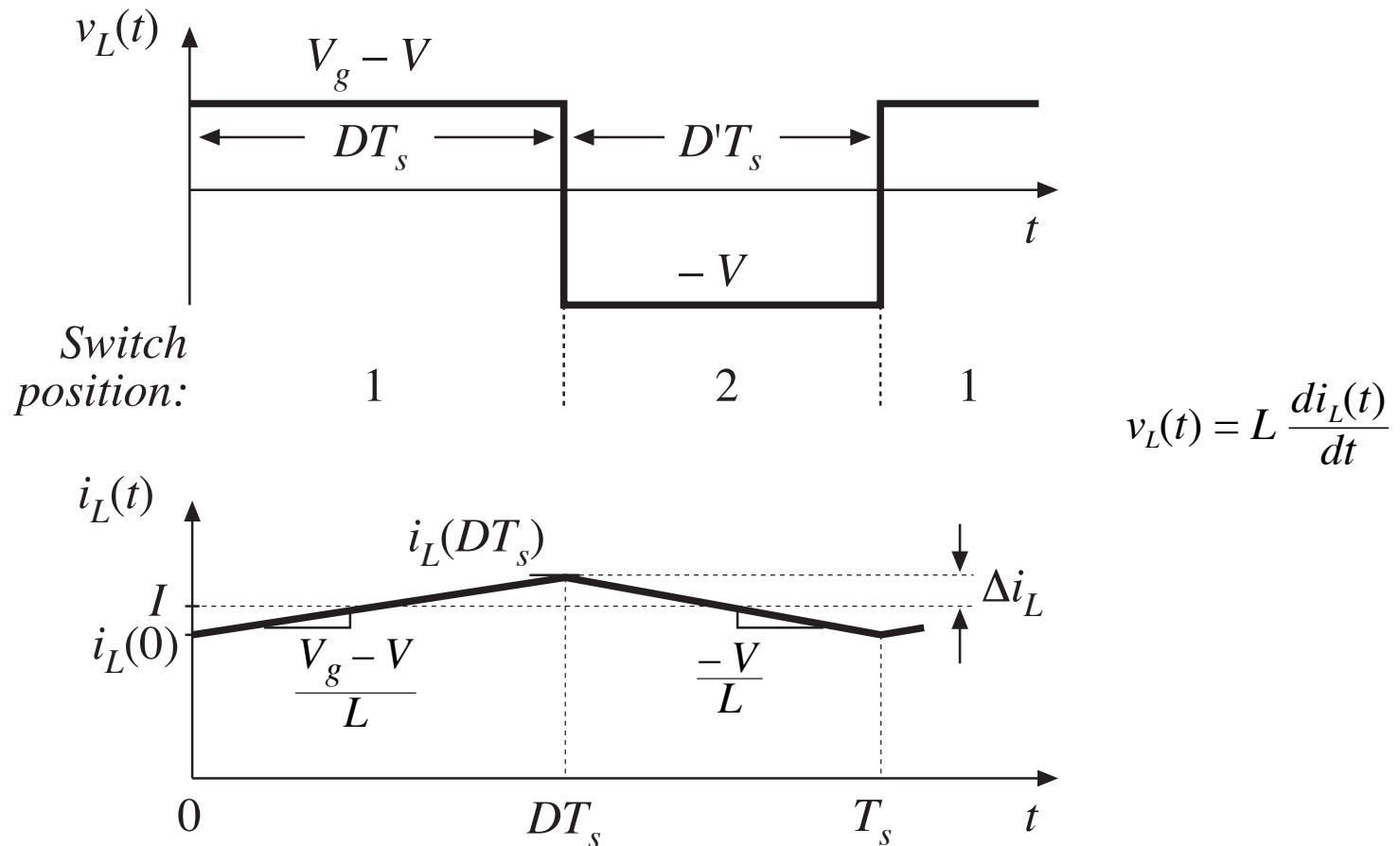

Determination of inductor current ripple magnitude

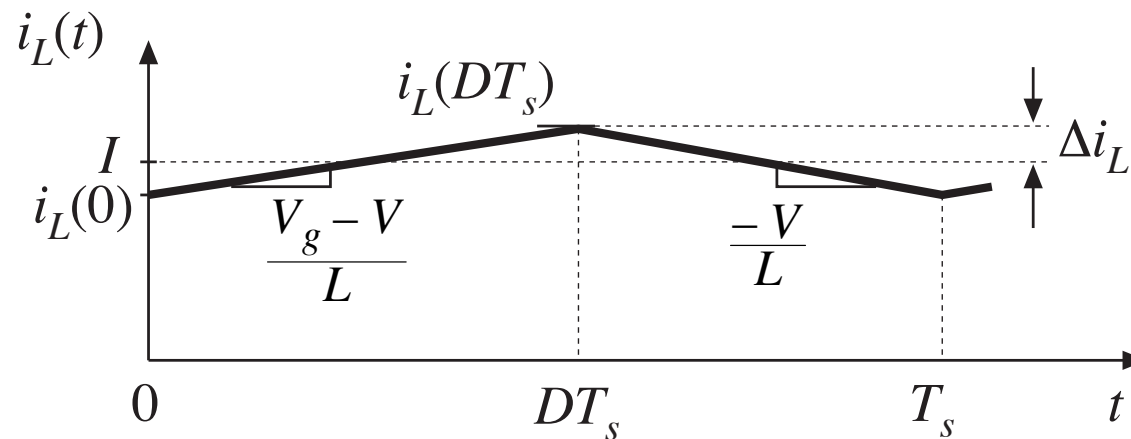

(change in i_L) = (slope)(length of subinterval)

$$(2\Delta i_L) = \left(\frac{V_g - V}{L} \right) (DT_s)$$

$$\Rightarrow \Delta i_L = \frac{V_g - V}{2L} DT_s \qquad L = \frac{V_g - V}{2\Delta i_L} DT_s$$

Inductor current waveform during turn-on transient

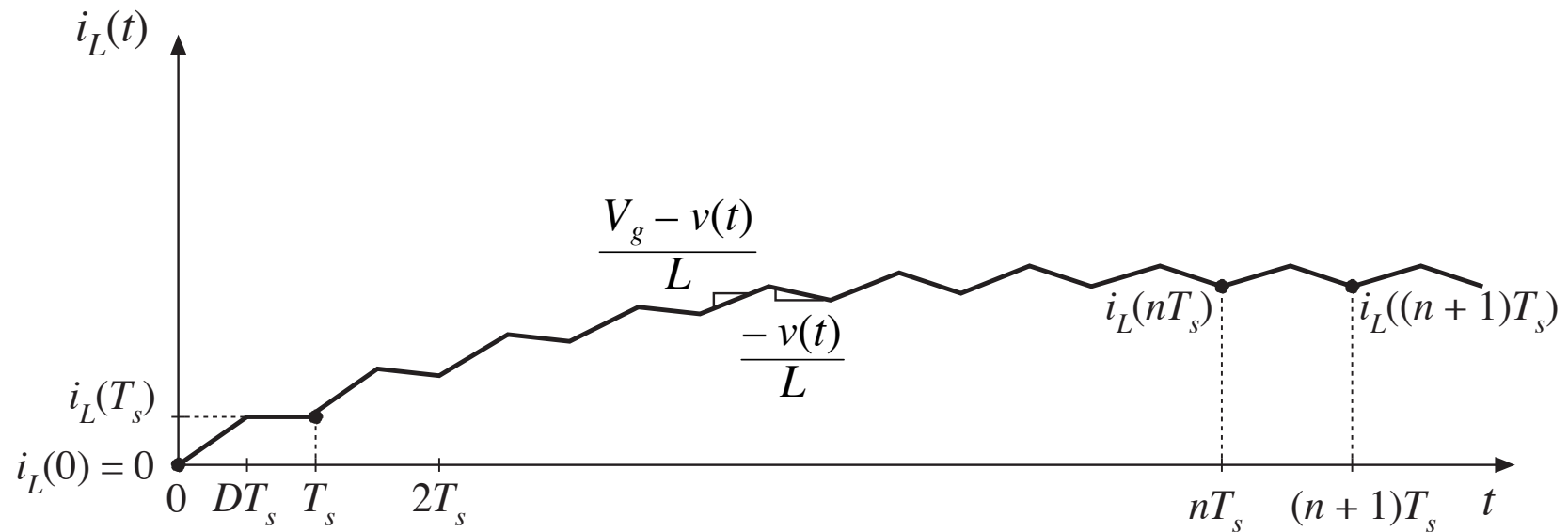

When the converter operates in equilibrium:

$$i_L((n+1)T_s) = i_L(nT_s)$$

The principle of inductor volt-second balance: Derivation

Inductor defining relation:

$$v_L(t) = L \frac{di_L(t)}{dt}$$

Integrate over one complete switching period:

$$i_L(T_s) - i_L(0) = \frac{1}{L} \int_0^{T_s} v_L(t) dt$$

In periodic steady state, the net change in inductor current is zero:

$$0 = \int_0^{T_s} v_L(t) dt$$

Hence, the total area (or volt-seconds) under the inductor voltage waveform is zero whenever the converter operates in steady state.

An equivalent form:

$$0 = \frac{1}{T_s} \int_0^{T_s} v_L(t) dt = \langle v_L \rangle$$

The average inductor voltage is zero in steady state.

Inductor volt-second balance: Buck converter example

Inductor voltage waveform,
previously derived:

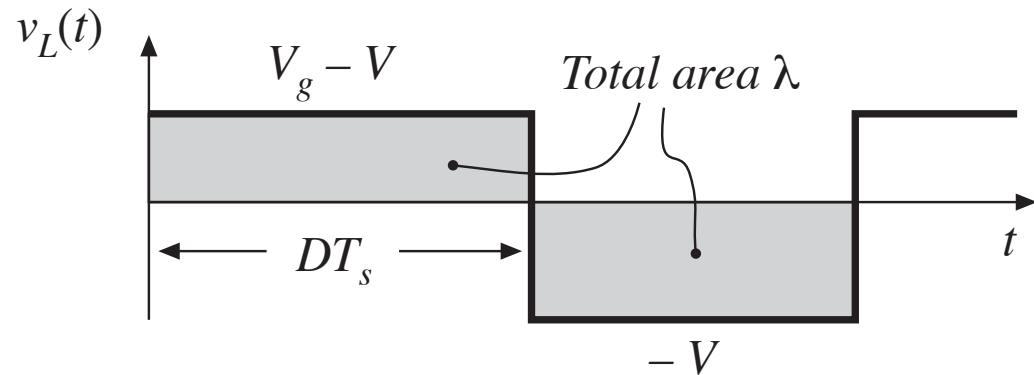

Integral of voltage waveform is area of rectangles:

$$\lambda = \int_0^{T_s} v_L(t) dt = (V_g - V)(DT_s) + (-V)(D'T_s)$$

Average voltage is

$$\langle v_L \rangle = \frac{\lambda}{T_s} = D(V_g - V) + D'(-V)$$

Equate to zero and solve for V :

$$0 = DV_g - (D + D')V = DV_g - V \quad \Rightarrow \quad V = DV_g$$

The principle of capacitor charge balance: Derivation

Capacitor defining relation:

$$i_c(t) = C \frac{dv_c(t)}{dt}$$

Integrate over one complete switching period:

$$v_c(T_s) - v_c(0) = \frac{1}{C} \int_0^{T_s} i_c(t) dt$$

In periodic steady state, the net change in capacitor voltage is zero:

$$0 = \frac{1}{T_s} \int_0^{T_s} i_c(t) dt = \langle i_c \rangle$$

Hence, the total area (or charge) under the capacitor current waveform is zero whenever the converter operates in steady state. The average capacitor current is then zero.

2.3 Boost converter example

*Boost converter
with ideal switch*

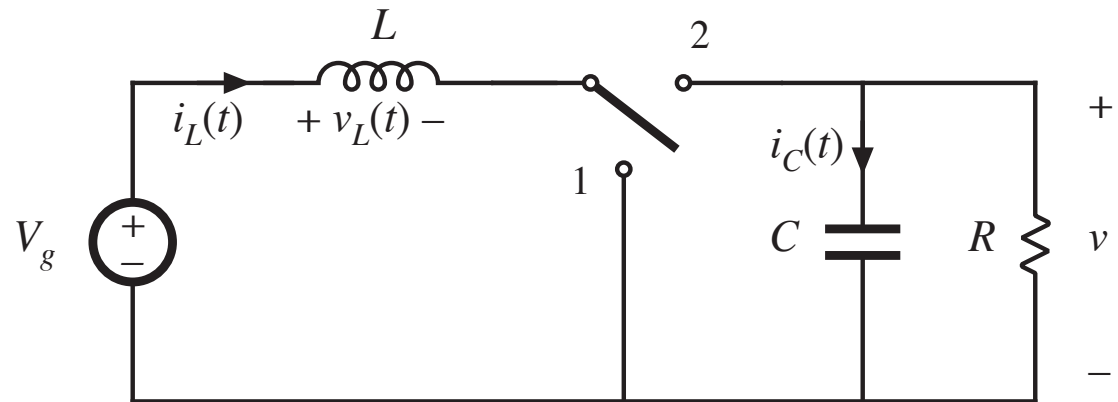

*Realization using
power MOSFET
and diode*

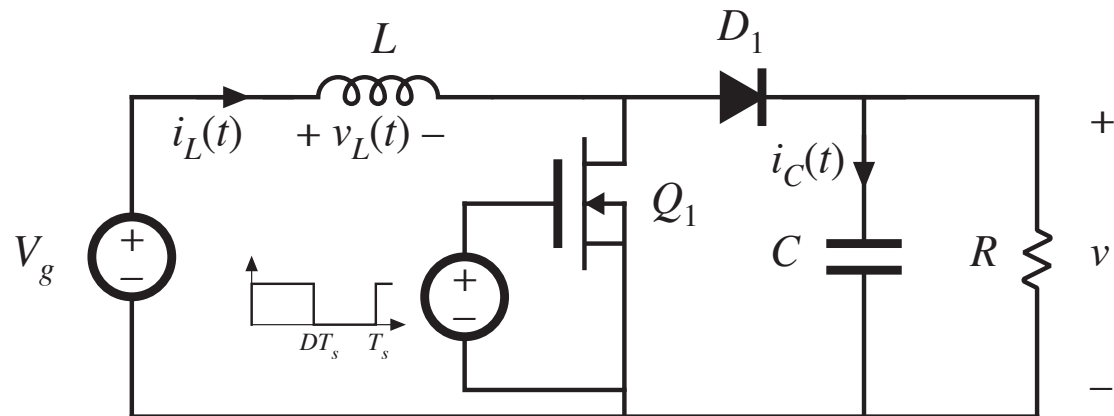

Boost converter analysis

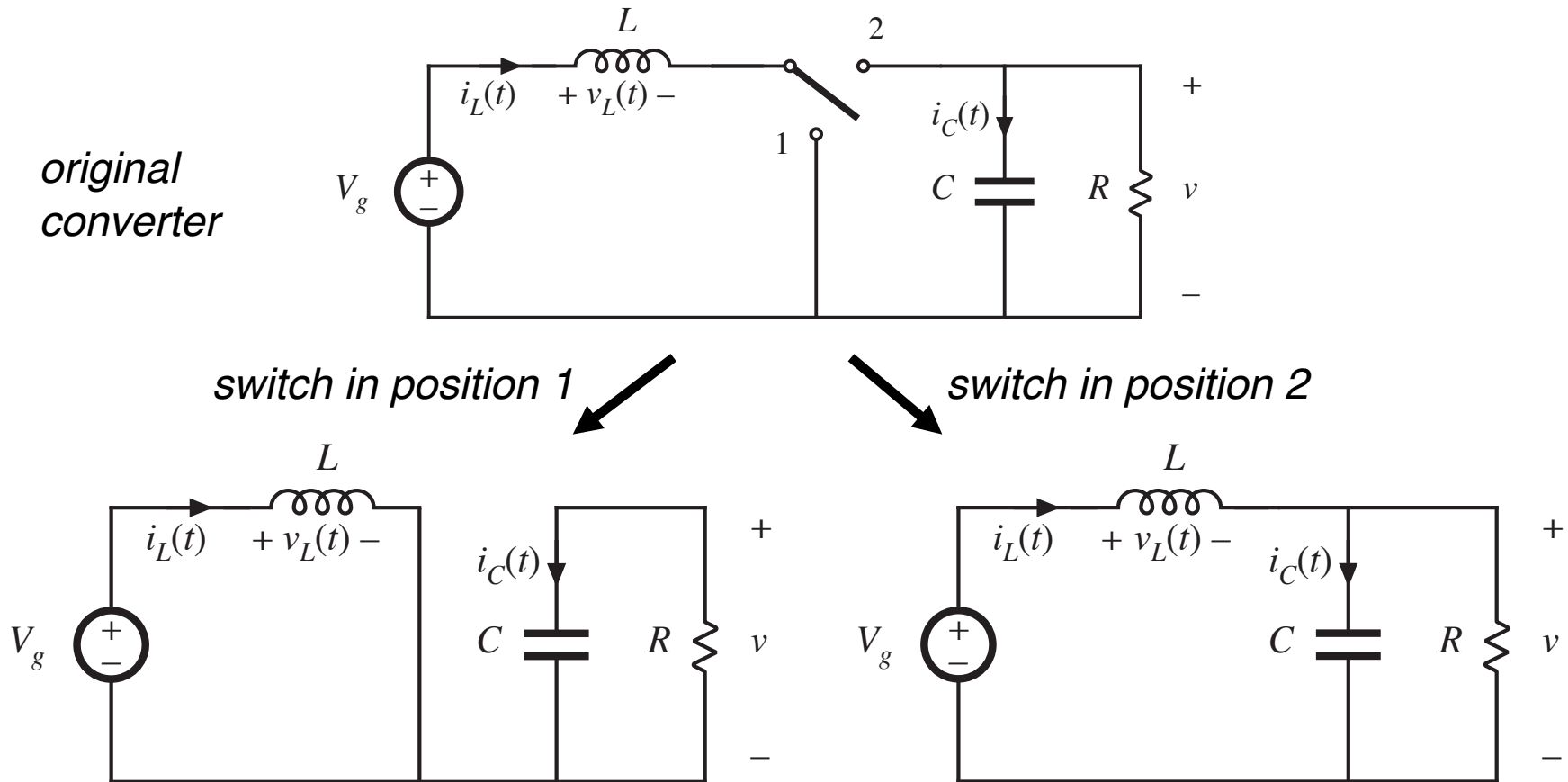

Subinterval 1: switch in position 1

Inductor voltage and capacitor current

$$v_L = V_g$$

$$i_C = -v / R$$

Small ripple approximation:

$$v_L = V_g$$

$$i_C = -V / R$$

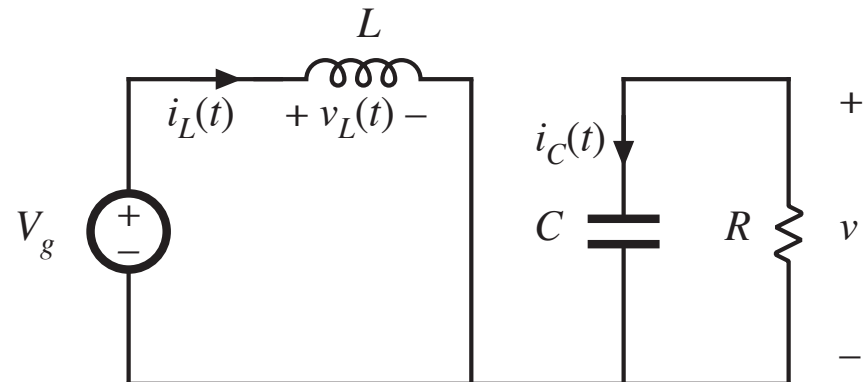

Subinterval 2: switch in position 2

Inductor voltage and capacitor current

$$v_L = V_g - v$$

$$i_C = i_L - v / R$$

Small ripple approximation:

$$v_L = V_g - V$$

$$i_C = I - V / R$$

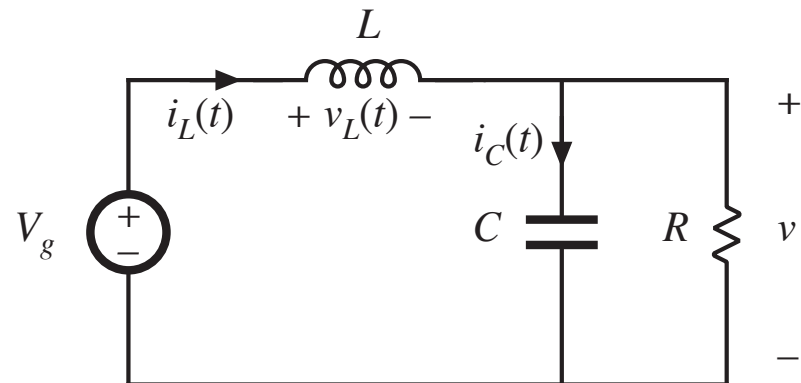

Inductor voltage and capacitor current waveforms

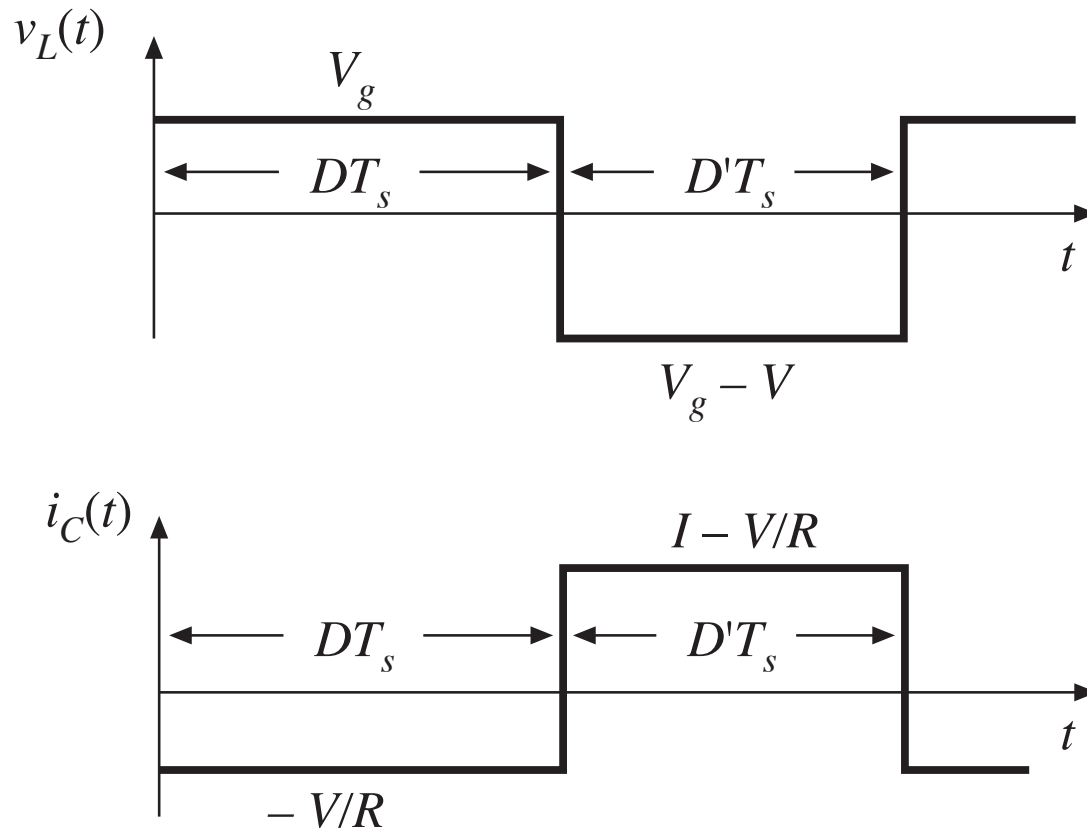

Inductor volt-second balance

Net volt-seconds applied to inductor over one switching period:

$$\int_0^{T_s} v_L(t) dt = (V_g) DT_s + (V_g - V) D'T_s$$

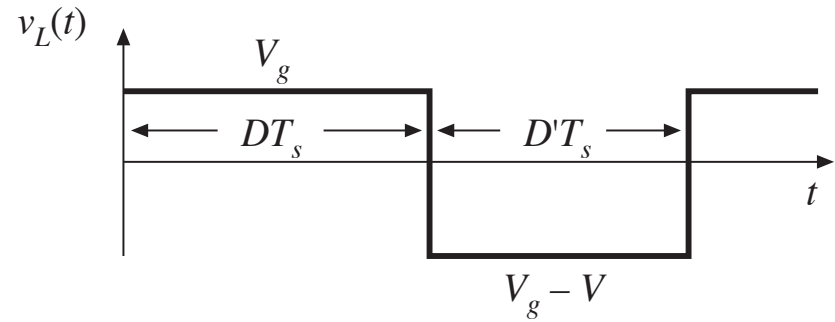

Equate to zero and collect terms:

$$V_g (D + D') - V D' = 0$$

Solve for V:

$$V = \frac{V_g}{D'}$$

The voltage conversion ratio is therefore

$$M(D) = \frac{V}{V_g} = \frac{1}{D'} = \frac{1}{1 - D}$$

Conversion ratio $M(D)$ of the boost converter

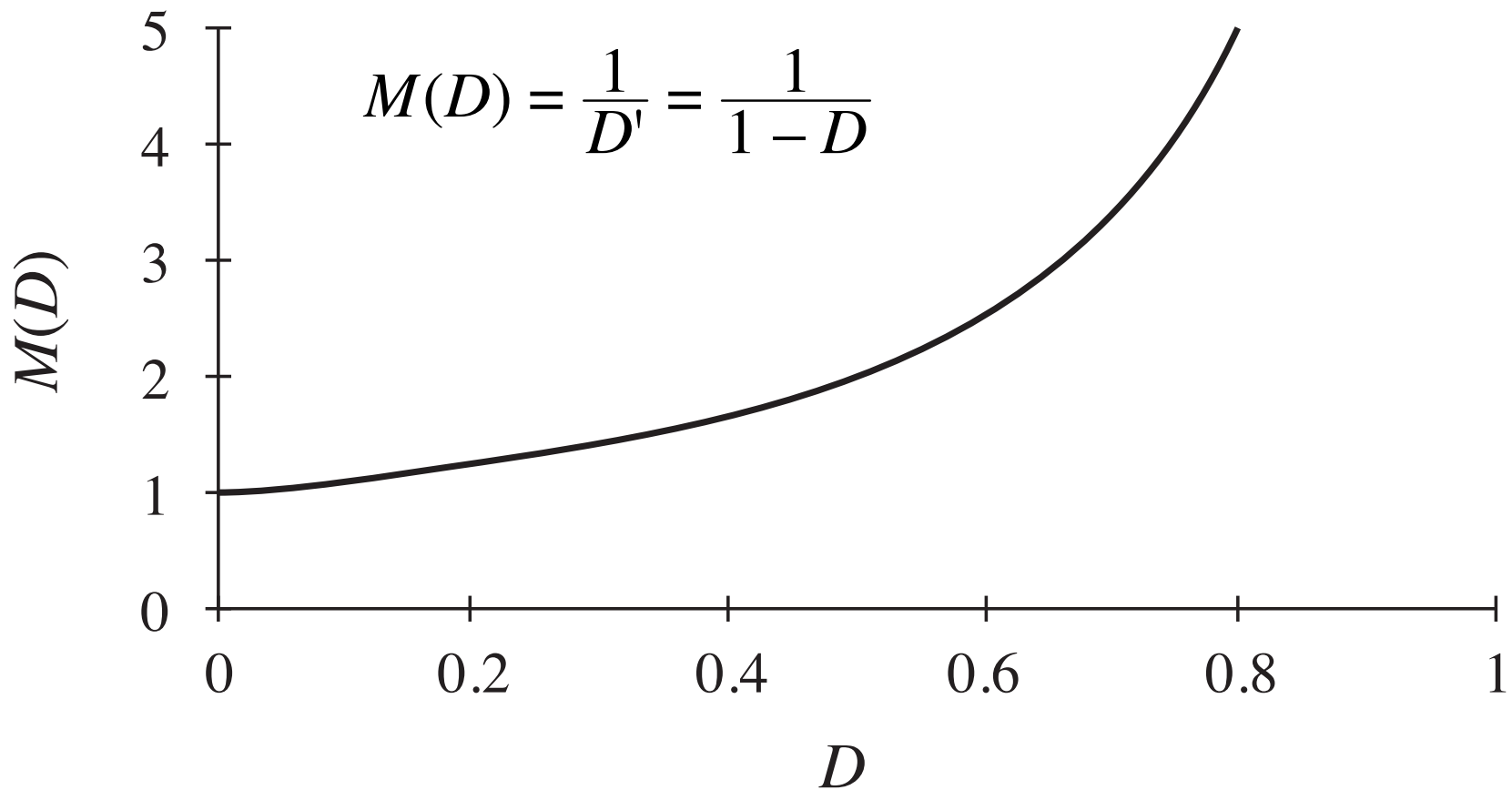

Determination of inductor current dc component

Capacitor charge balance:

$$\int_0^{T_s} i_C(t) dt = \left(-\frac{V}{R}\right) DT_s + \left(I - \frac{V}{R}\right) D'T_s$$

Collect terms and equate to zero:

$$-\frac{V}{R} (D + D') + I D' = 0$$

Solve for I :

$$I = \frac{V}{D' R}$$

Eliminate V to express in terms of V_g :

$$I = \frac{V_g}{D'^2 R}$$

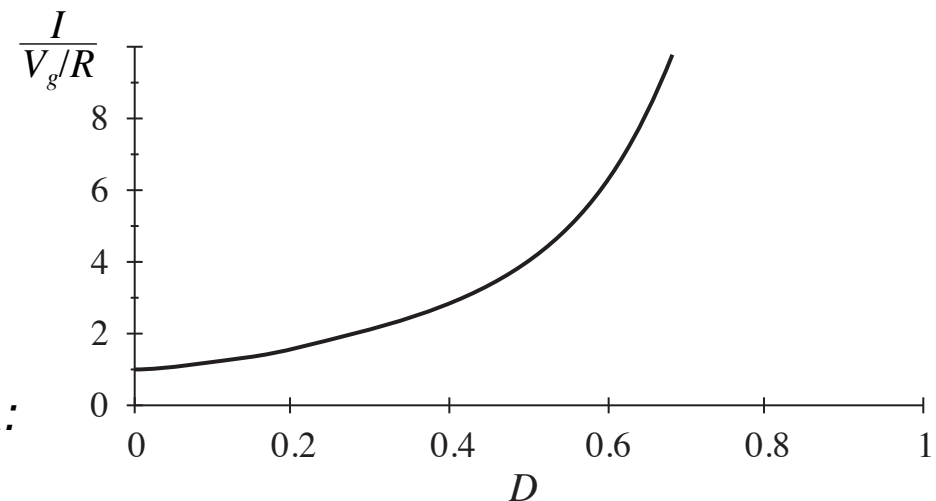
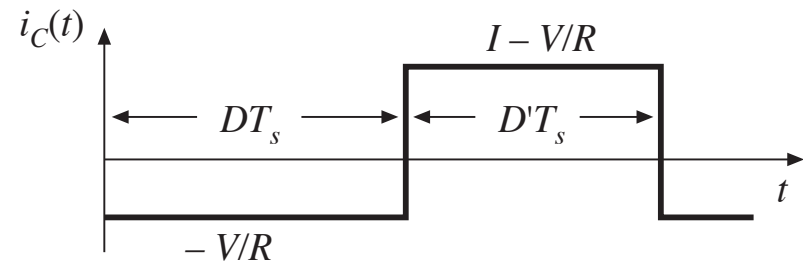

Determination of inductor current ripple

Inductor current slope during subinterval 1:

$$\frac{di_L(t)}{dt} = \frac{v_L(t)}{L} = \frac{V_g}{L}$$

Inductor current slope during subinterval 2:

$$\frac{di_L(t)}{dt} = \frac{v_L(t)}{L} = \frac{V_g - V}{L}$$

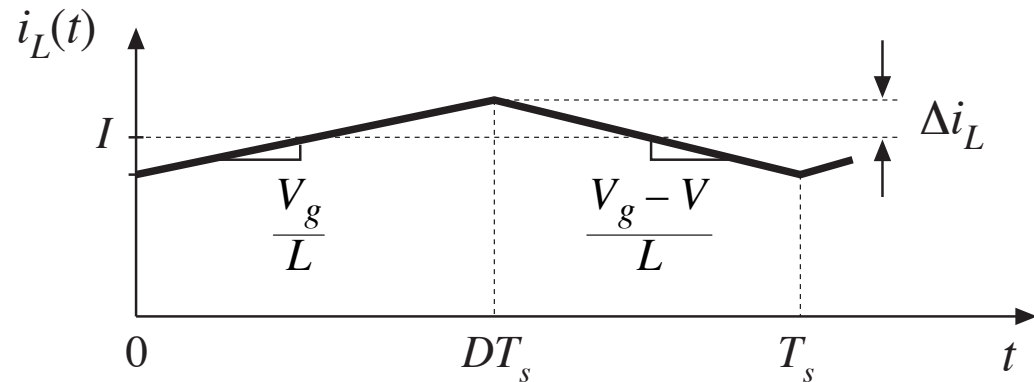

Change in inductor current during subinterval 1 is (slope) (length of subinterval):

$$2\Delta i_L = \frac{V_g}{L} DT_s$$

Solve for peak ripple:

$$\Delta i_L = \frac{V_g}{2L} DT_s$$

- Choose L such that desired ripple magnitude is obtained

Determination of capacitor voltage ripple

Capacitor voltage slope during subinterval 1:

$$\frac{dv_c(t)}{dt} = \frac{i_c(t)}{C} = \frac{-V}{RC}$$

Capacitor voltage slope during subinterval 2:

$$\frac{dv_c(t)}{dt} = \frac{i_c(t)}{C} = \frac{I}{C} - \frac{V}{RC}$$

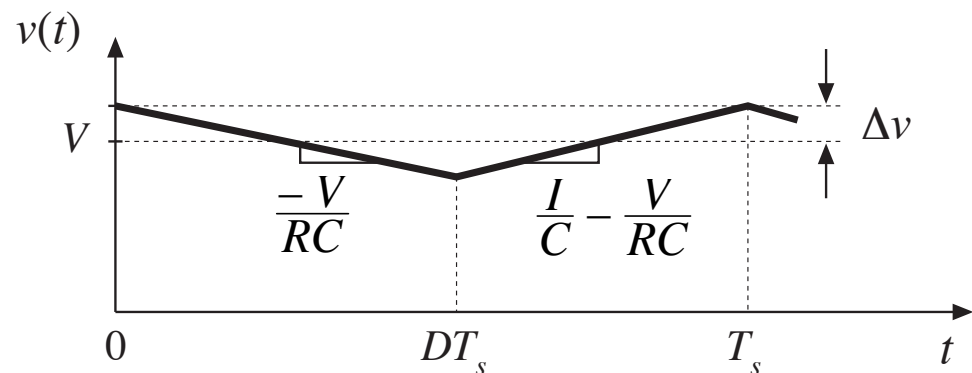

Change in capacitor voltage during subinterval 1 is (*slope*) (*length of subinterval*):

$$-2\Delta v = \frac{-V}{RC} DT_s$$

Solve for peak ripple:

$$\Delta v = \frac{V}{2RC} DT_s$$

- Choose C such that desired voltage ripple magnitude is obtained
- In practice, capacitor *equivalent series resistance* (esr) leads to increased voltage ripple

2.4 Cuk converter example

*Cuk converter,
with ideal switch*

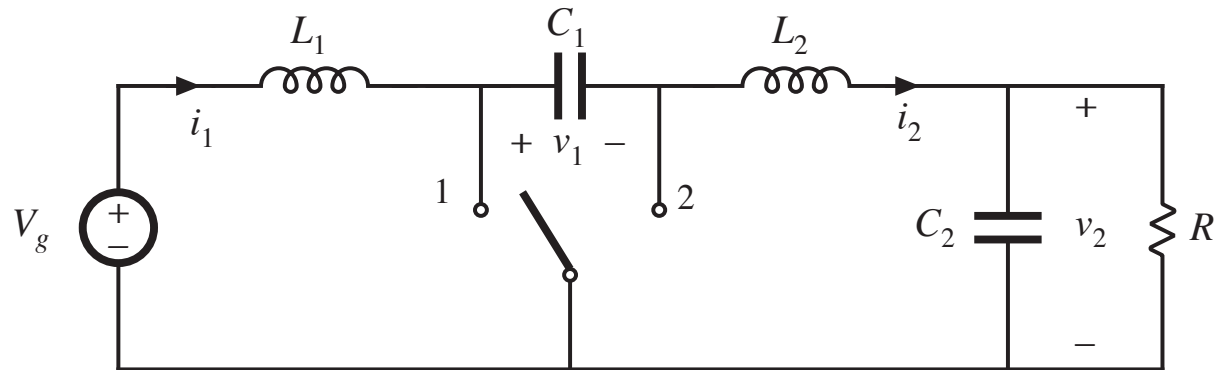

*Cuk converter:
practical realization
using MOSFET and
diode*

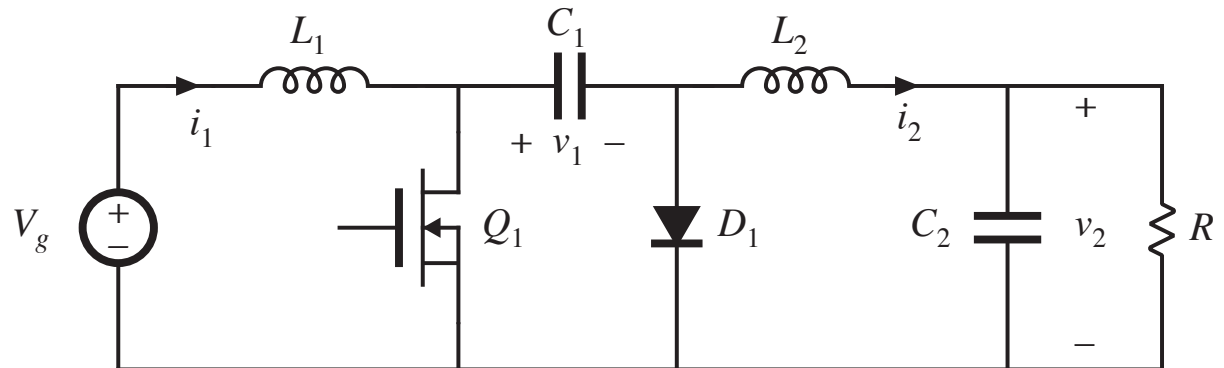

Analysis strategy

This converter has two inductor currents and two capacitor voltages, that can be expressed as

$$i_1(t) = I_1 + i_{1-ripple}(t)$$

$$i_2(t) = I_2 + i_{2-ripple}(t)$$

$$v_1(t) = V_1 + v_{1-ripple}(t)$$

$$v_2(t) = V_2 + v_{2-ripple}(t)$$

To solve the converter in steady state, we want to find the dc components I_1 , I_2 , V_1 , and V_2 , when the ripples are small.

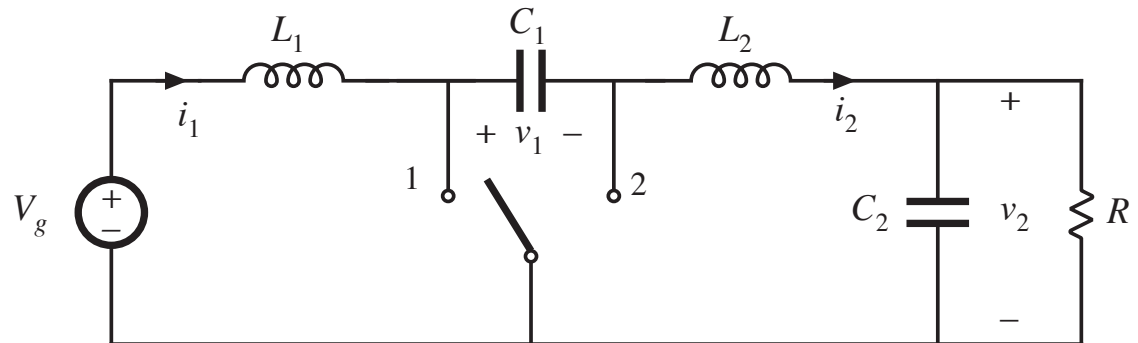

Strategy:

- Apply volt-second balance to each inductor voltage
- Apply charge balance to each capacitor current
- Simplify using the small ripple approximation
- Solve the resulting four equations for the four unknowns I_1 , I_2 , V_1 , and V_2 .

Cuk converter circuit with switch in positions 1 and 2

Switch in position 1:
MOSFET conducts
Capacitor C_1 releases
energy to output

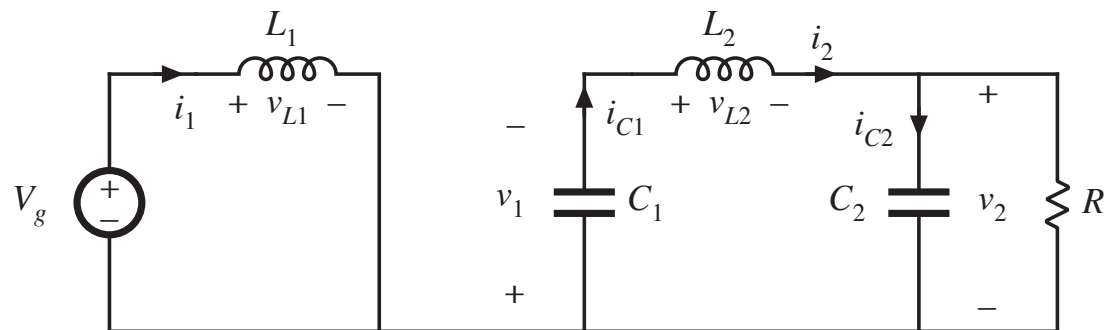

Switch in position 2:
diode conducts
Capacitor C_1 is
charged from input

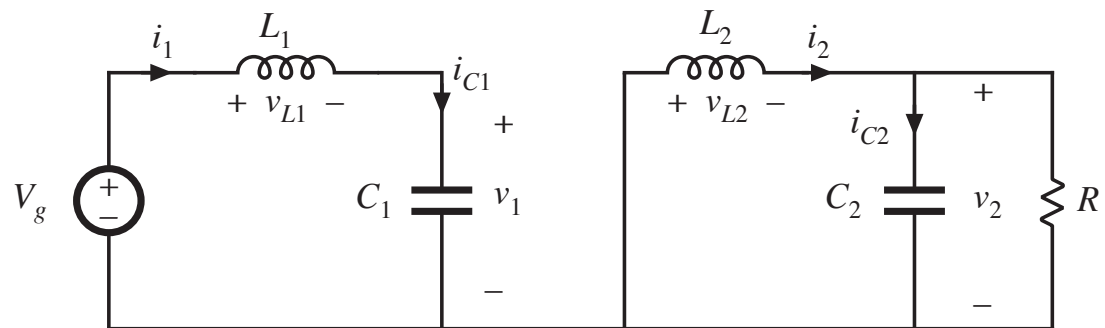

Waveforms during subinterval 1

MOSFET conduction interval

Inductor voltages and capacitor currents:

$$v_{L1} = V_g$$

$$v_{L2} = -v_1 - v_2$$

$$i_{C1} = i_2$$

$$i_{C2} = i_2 - \frac{v_2}{R}$$

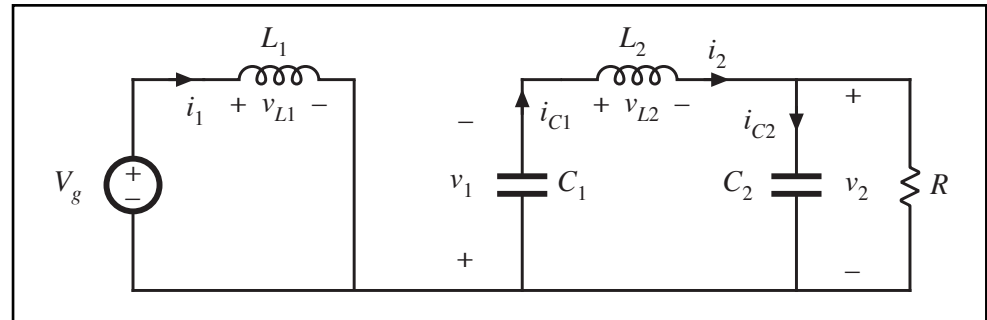

Small ripple approximation for subinterval 1:

$$v_{L1} = V_g$$

$$v_{L2} = -V_1 - V_2$$

$$i_{C1} = I_2$$

$$i_{C2} = I_2 - \frac{V_2}{R}$$

Waveforms during subinterval 2

Diode conduction interval

Inductor voltages and capacitor currents:

$$v_{L1} = V_g - v_1$$

$$v_{L2} = -v_2$$

$$i_{C1} = i_1$$

$$i_{C2} = i_2 - \frac{v_2}{R}$$

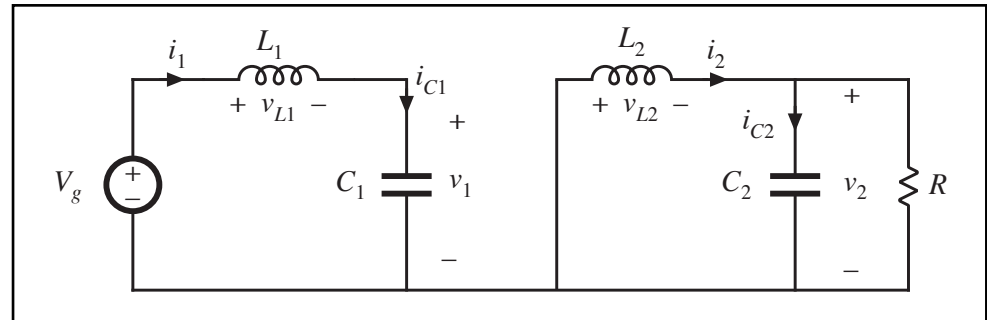

Small ripple approximation for subinterval 2:

$$v_{L1} = V_g - V_1$$

$$v_{L2} = -V_2$$

$$i_{C1} = I_1$$

$$i_{C2} = I_2 - \frac{V_2}{R}$$

Equate average values to zero

The principles of inductor volt-second and capacitor charge balance state that the average values of the periodic inductor voltage and capacitor current waveforms are zero, when the converter operates in steady state. Hence, to determine the steady-state conditions in the converter, let us sketch the inductor voltage and capacitor current waveforms, and equate their average values to zero.

Waveforms:

Inductor voltage $v_{L1}(t)$

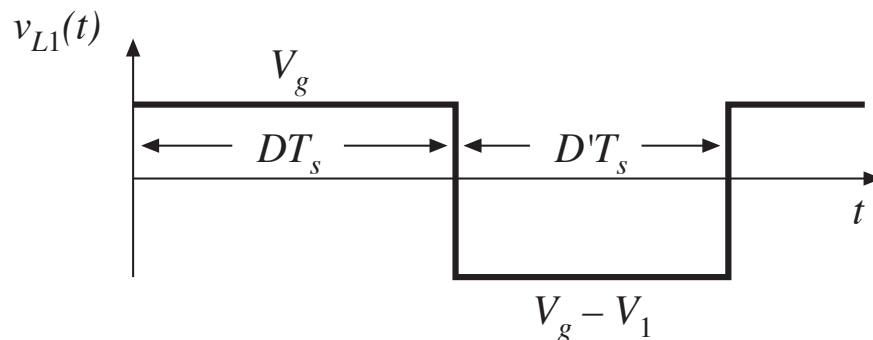

Volt-second balance on L_1 :

$$\langle v_{L1} \rangle = DV_g + D'(V_g - V_1) = 0$$

Equate average values to zero

Inductor L_2 voltage

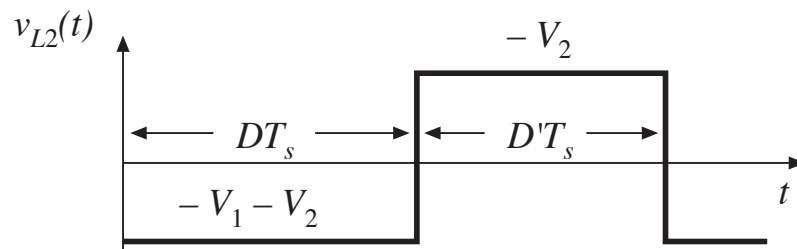

Average the waveforms:

$$\langle v_{L2} \rangle = D(-V_1 - V_2) + D'(-V_2) = 0$$

$$\langle i_{C1} \rangle = DI_2 + D'I_1 = 0$$

Capacitor C_1 current

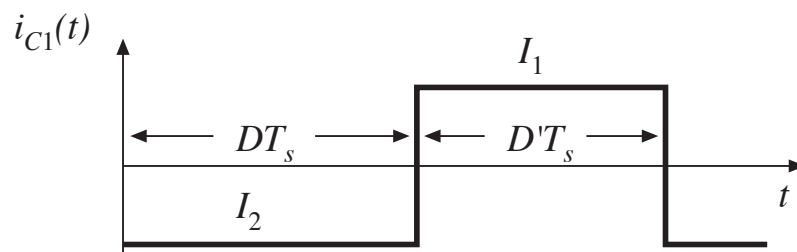

Equate average values to zero

Capacitor current $i_{C2}(t)$ waveform

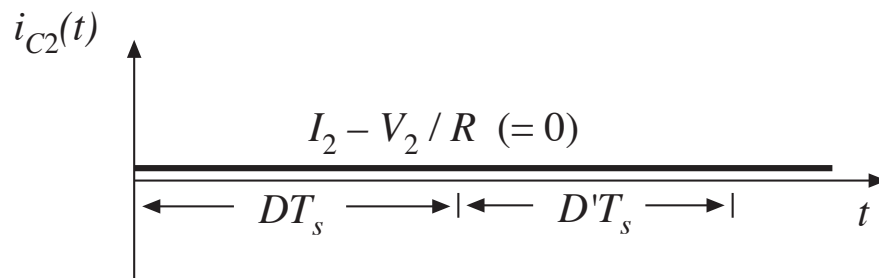

$$\langle i_{C2} \rangle = I_2 - \frac{V_2}{R} = 0$$

Note: during both subintervals, the capacitor current i_{C2} is equal to the difference between the inductor current i_2 and the load current V_2/R . When ripple is neglected, i_{C2} is constant and equal to zero.

Solve for steady-state inductor currents and capacitor voltages

The four equations obtained from volt-sec and charge balance:

$$\langle v_{L1} \rangle = DV_g + D'(V_g - V_1) = 0$$

$$\langle v_{L2} \rangle = D(-V_1 - V_2) + D'(-V_2) = 0$$

$$\langle i_{C1} \rangle = DI_2 + D'I_1 = 0$$

$$\langle i_{C2} \rangle = I_2 - \frac{V_2}{R} = 0$$

Solve for the dc capacitor voltages and inductor currents, and express in terms of the known V_g , D , and R :

$$V_1 = \frac{V_g}{D'}$$

$$V_2 = -\frac{D}{D'} V_g$$

$$I_1 = -\frac{D}{D'} I_2 = \left(\frac{D}{D'}\right)^2 \frac{V_g}{R}$$

$$I_2 = \frac{V_2}{R} = -\frac{D}{D'} \frac{V_g}{R}$$

Cuk converter conversion ratio $M = V / V_g$

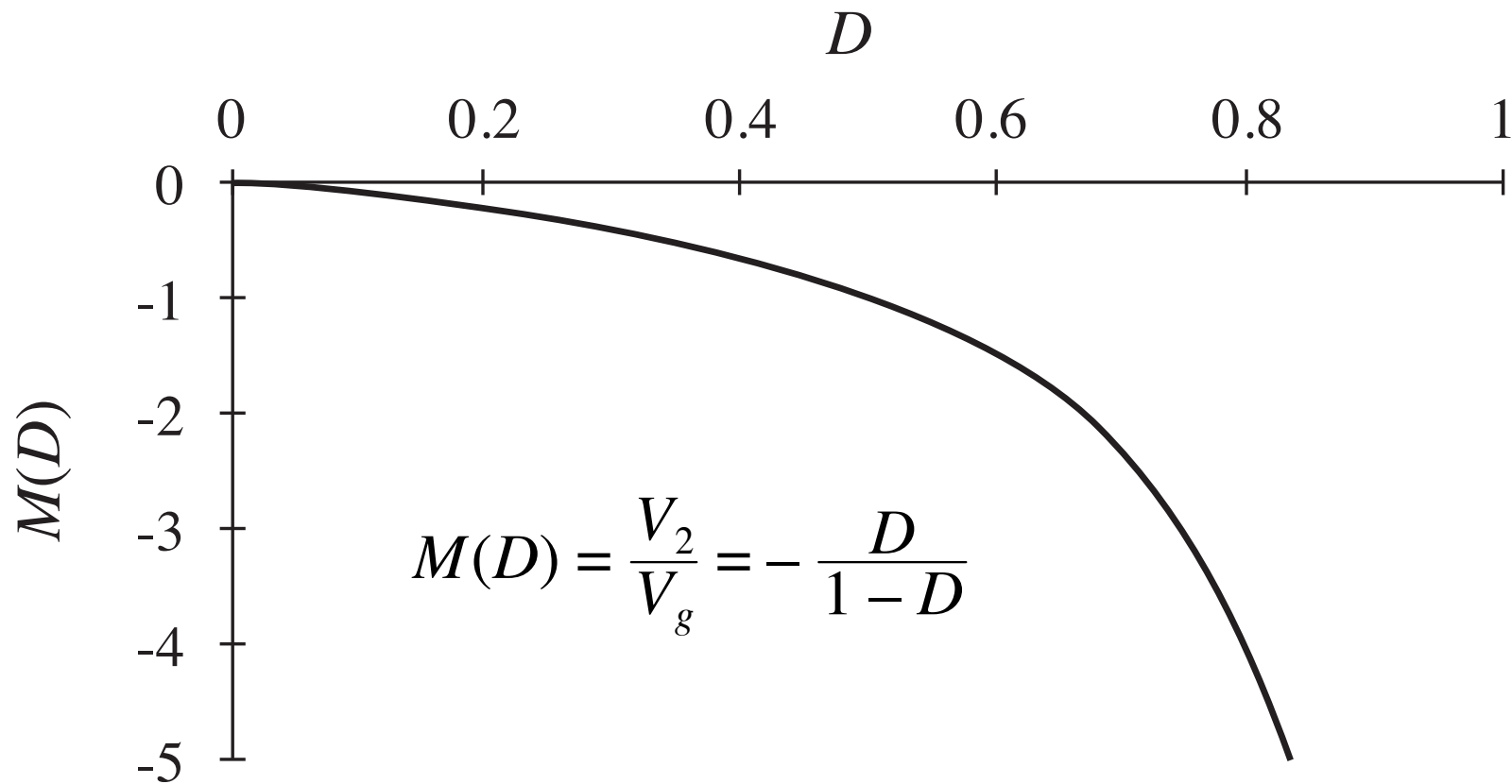

Inductor current waveforms

Interval 1 slopes, using small ripple approximation:

$$\frac{di_1(t)}{dt} = \frac{v_{L1}(t)}{L_1} = \frac{V_g}{L_1}$$

$$\frac{di_2(t)}{dt} = \frac{v_{L2}(t)}{L_2} = \frac{-V_1 - V_2}{L_2}$$

Interval 2 slopes:

$$\frac{di_1(t)}{dt} = \frac{v_{L1}(t)}{L_1} = \frac{V_g - V_1}{L_1}$$

$$\frac{di_2(t)}{dt} = \frac{v_{L2}(t)}{L_2} = \frac{-V_2}{L_2}$$

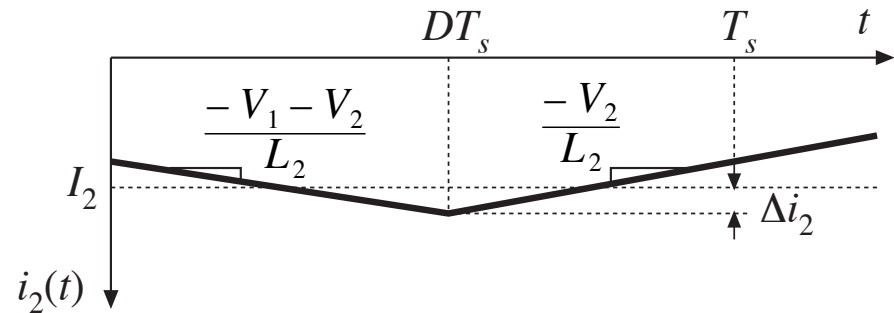
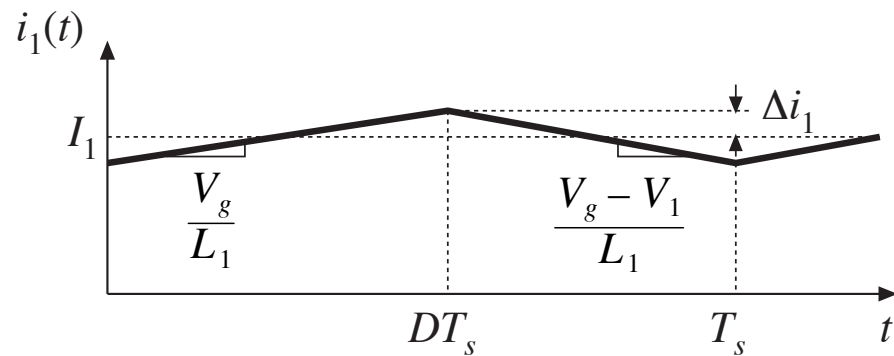

Capacitor C_1 waveform

Subinterval 1:

$$\frac{dv_1(t)}{dt} = \frac{i_{C1}(t)}{C_1} = \frac{I_2}{C_1}$$

Subinterval 2:

$$\frac{dv_1(t)}{dt} = \frac{i_{C1}(t)}{C_1} = \frac{I_1}{C_1}$$

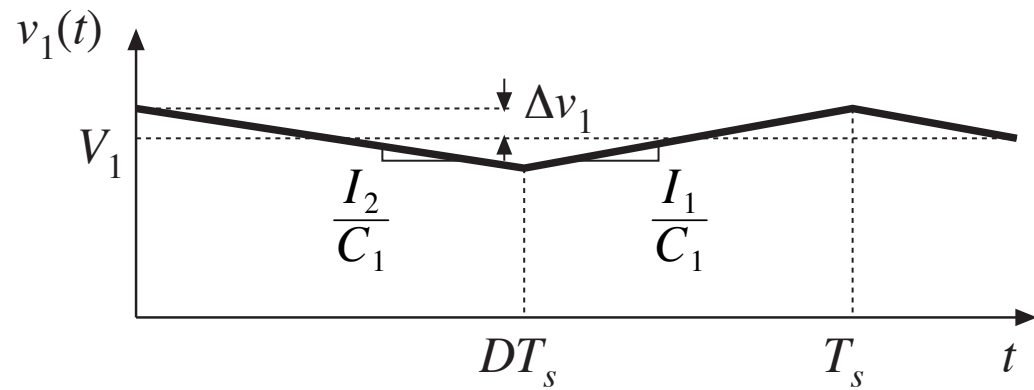

Ripple magnitudes

Analysis results

$$\Delta i_1 = \frac{V_g D T_s}{2L_1}$$

$$\Delta i_2 = \frac{V_1 + V_2}{2L_2} D T_s$$

$$\Delta v_1 = \frac{-I_2 D T_s}{2C_1}$$

Use dc converter solution to simplify:

$$\Delta i_1 = \frac{V_g D T_s}{2L_1}$$

$$\Delta i_2 = \frac{V_g D T_s}{2L_2}$$

$$\Delta v_1 = \frac{V_g D^2 T_s}{2D'RC_1}$$

Q: How large is the output voltage ripple?

2.5 Estimating ripple in converters containing two-pole low-pass filters

Buck converter example: Determine output voltage ripple

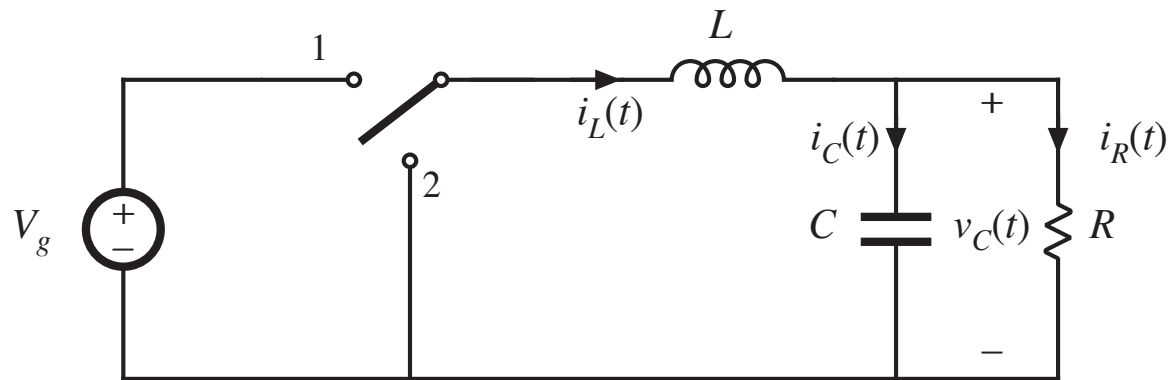

Inductor current waveform.

What is the capacitor current?

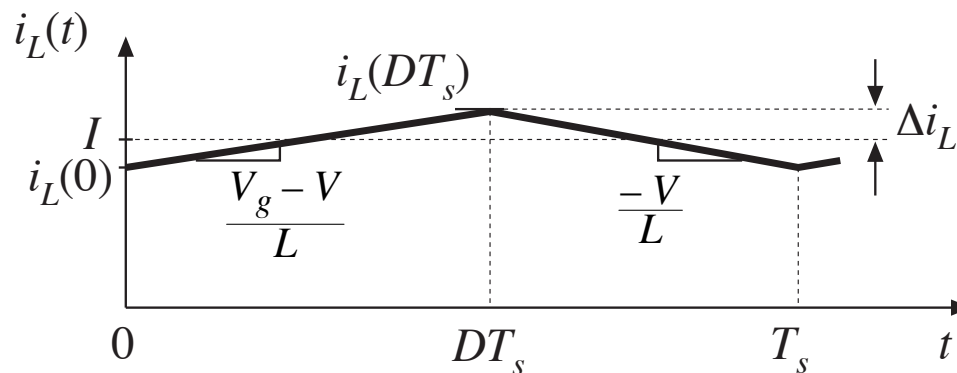

Capacitor current and voltage, buck example

Must not neglect inductor current ripple!

If the capacitor voltage ripple is small, then essentially all of the ac component of inductor current flows through the capacitor.

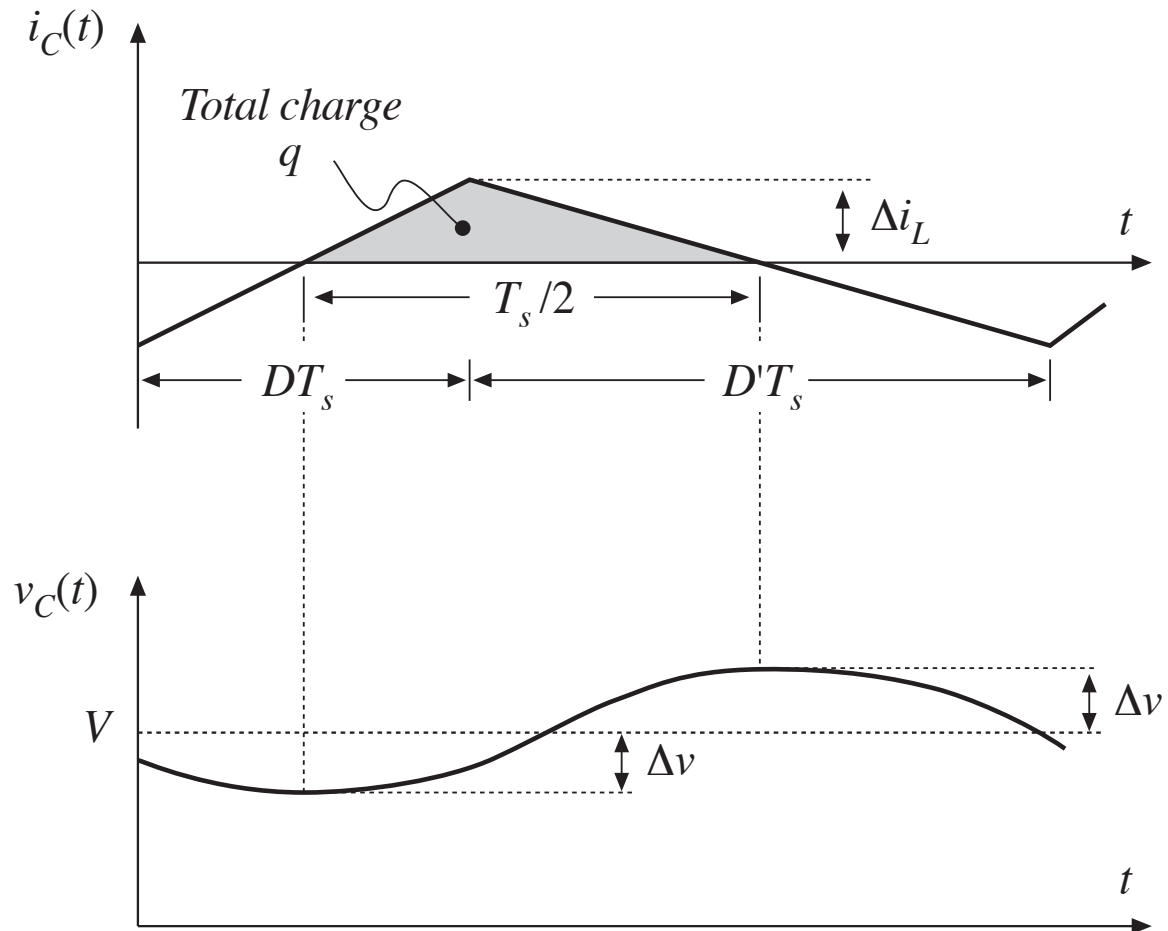

Estimating capacitor voltage ripple Δv

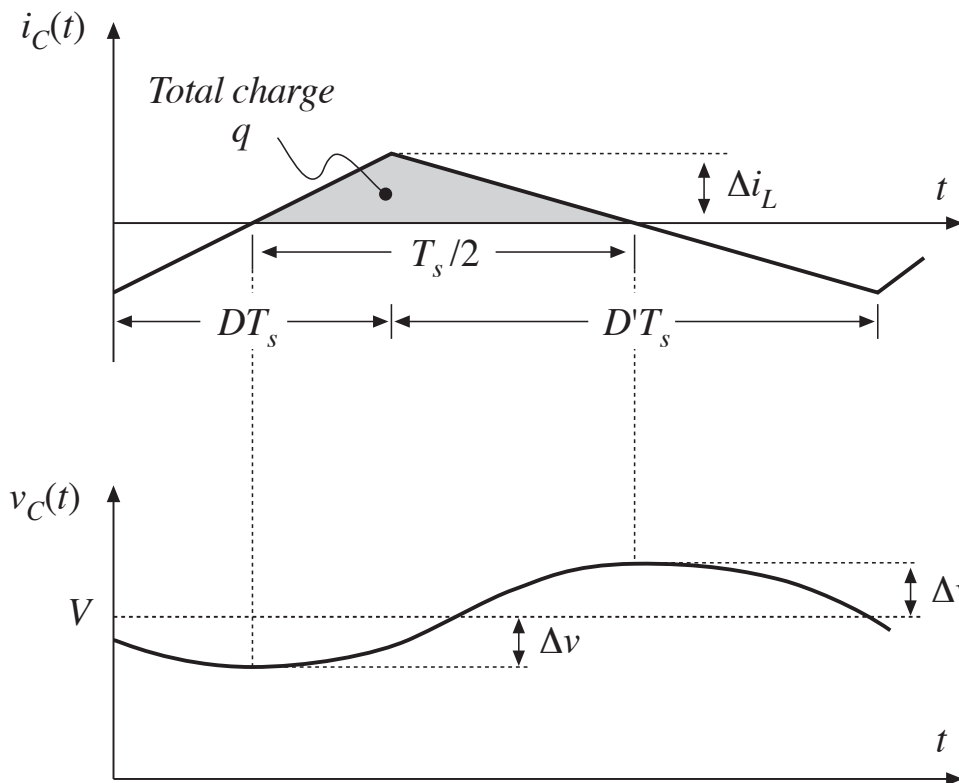

Current $i_C(t)$ is positive for half of the switching period. This positive current causes the capacitor voltage $v_C(t)$ to increase between its minimum and maximum extrema. During this time, the total charge q is deposited on the capacitor plates, where

$$q = C (2\Delta v)$$

$$\begin{aligned} (\text{change in charge}) &= \\ C (\text{change in voltage}) \end{aligned}$$

Estimating capacitor voltage ripple Δv

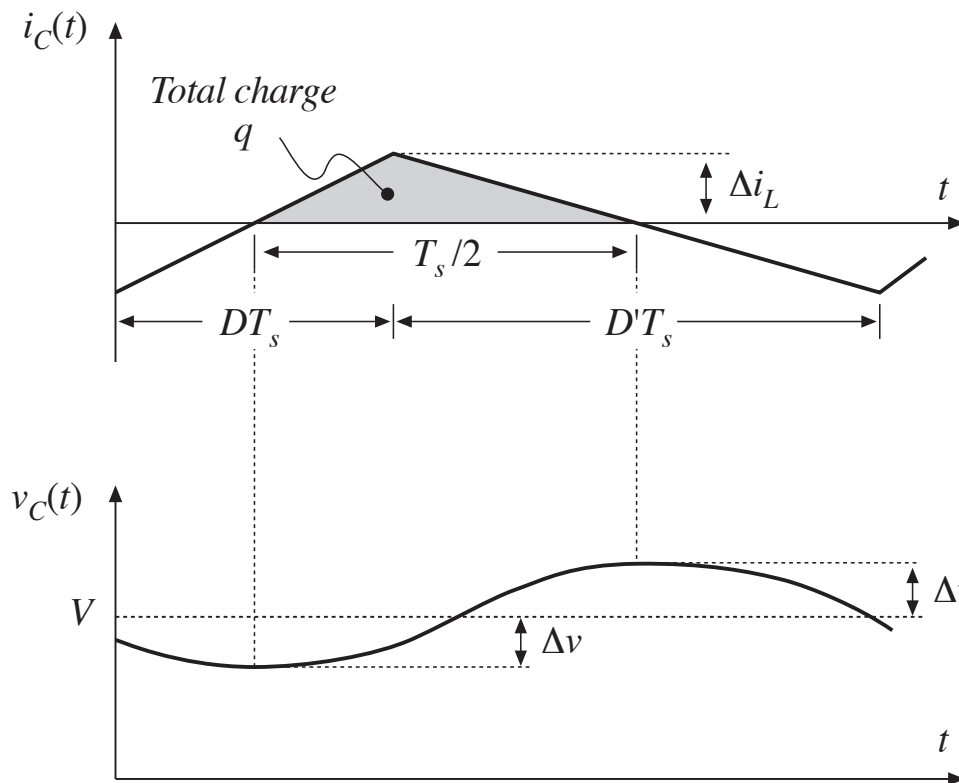

The total charge q is the area of the triangle, as shown:

$$q = \frac{1}{2} \Delta i_L \frac{T_s}{2}$$

Eliminate q and solve for Δv :

$$\Delta v = \frac{\Delta i_L T_s}{8 C}$$

Note: in practice, capacitor equivalent series resistance (esr) further increases Δv .

Inductor current ripple in two-pole filters

Example:
problem 2.9

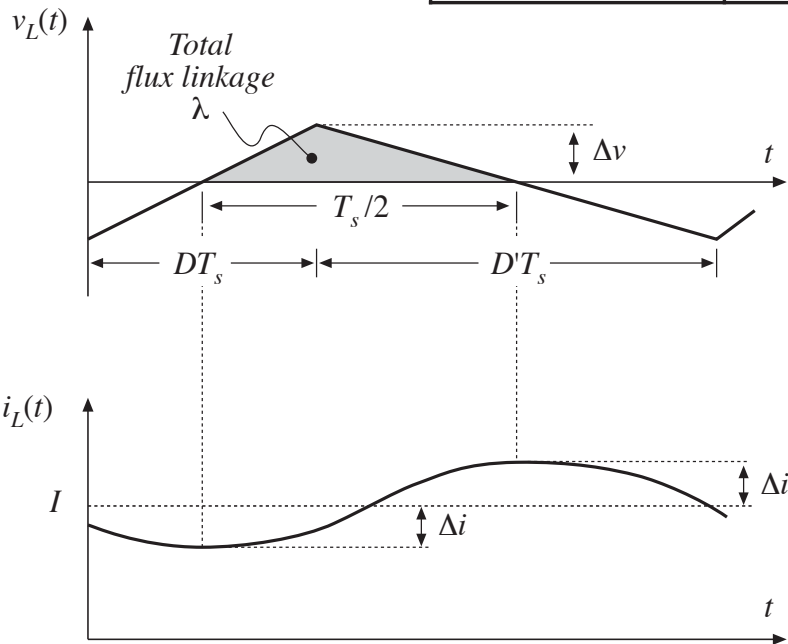
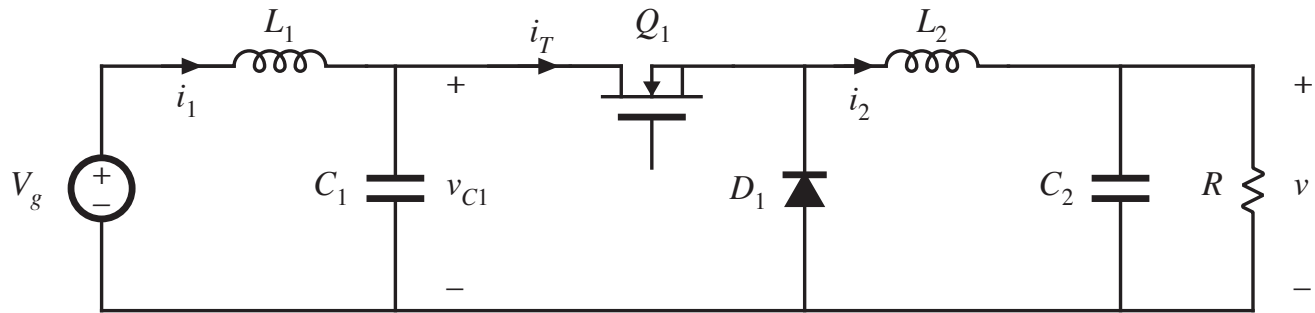

can use similar arguments, with

$$\lambda = L (2\Delta i)$$

λ = inductor flux linkages

= inductor volt-seconds

2.6 Summary of Key Points

1. The dc component of a converter waveform is given by its average value, or the integral over one switching period, divided by the switching period. Solution of a dc-dc converter to find its dc, or steady-state, voltages and currents therefore involves averaging the waveforms.
2. The linear ripple approximation greatly simplifies the analysis. In a well-designed converter, the switching ripples in the inductor currents and capacitor voltages are small compared to the respective dc components, and can be neglected.
3. The principle of inductor volt-second balance allows determination of the dc voltage components in any switching converter. In steady-state, the average voltage applied to an inductor must be zero.

Summary of Chapter 2

4. The principle of capacitor charge balance allows determination of the dc components of the inductor currents in a switching converter. In steady-state, the average current applied to a capacitor must be zero.
5. By knowledge of the slopes of the inductor current and capacitor voltage waveforms, the ac switching ripple magnitudes may be computed. Inductance and capacitance values can then be chosen to obtain desired ripple magnitudes.
6. In converters containing multiple-pole filters, continuous (nonpulsating) voltages and currents are applied to one or more of the inductors or capacitors. Computation of the ac switching ripple in these elements can be done using capacitor charge and/or inductor flux-linkage arguments, without use of the small-ripple approximation.
7. Converters capable of increasing (boost), decreasing (buck), and inverting the voltage polarity (buck-boost and Cuk) have been described. Converter circuits are explored more fully in a later chapter.