

# Part II

## Converter Dynamics and Control

---

7. AC equivalent circuit modeling
8. Converter transfer functions
9. Controller design
10. Ac and dc equivalent circuit modeling of the discontinuous conduction mode
11. Current programmed control

# Chapter 7. AC Equivalent Circuit Modeling

---

- 7.1. Introduction
- 7.2. The basic ac modeling approach
- 7.3. Example: A nonideal flyback converter
- 7.4. State-space averaging
- 7.5. Circuit averaging and averaged switch modeling
- 7.6. The canonical circuit model
- 7.7. Modeling the pulse-width modulator
- 7.8. Summary of key points

# 7.1. Introduction

Objective: maintain  $v(t)$  equal to an accurate, constant value  $V$ .

There are disturbances:

- in  $v_g(t)$
- in  $R$

There are uncertainties:

- in element values
- in  $V_g$
- in  $R$

*A simple dc-dc regulator system, employing a buck converter*

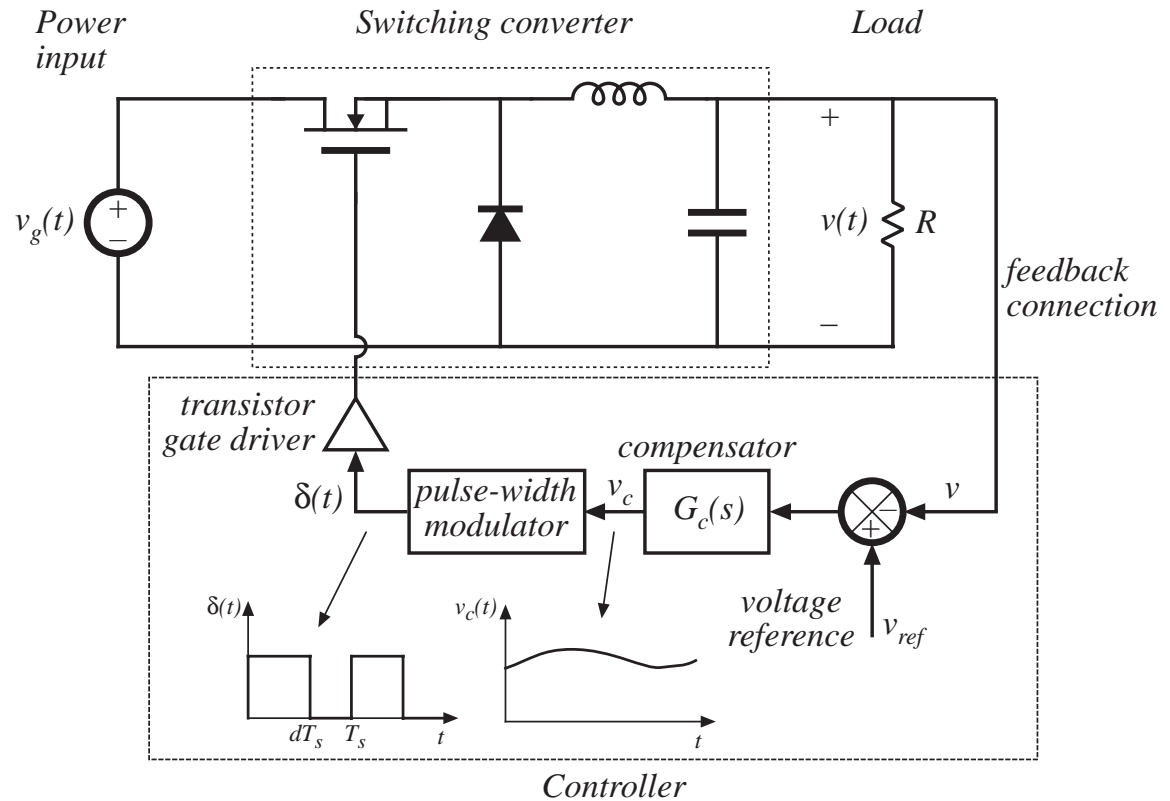

# Applications of control in power electronics

---

## *Dc-dc converters*

Regulate dc output voltage.

Control the duty cycle  $d(t)$  such that  $v(t)$  accurately follows a reference signal  $v_{ref}$ .

## *Dc-ac inverters*

Regulate an ac output voltage.

Control the duty cycle  $d(t)$  such that  $v(t)$  accurately follows a reference signal  $v_{ref}(t)$ .

## *Ac-dc rectifiers*

Regulate the dc output voltage.

Regulate the ac input current waveform.

Control the duty cycle  $d(t)$  such that  $i_g(t)$  accurately follows a reference signal  $i_{ref}(t)$ , and  $v(t)$  accurately follows a reference signal  $v_{ref}$ .

# Objective of Part II

---

Develop tools for modeling, analysis, and design of converter control systems

Need dynamic models of converters:

How do ac variations in  $v_g(t)$ ,  $R$ , or  $d(t)$  affect the output voltage  $v(t)$ ?

What are the small-signal transfer functions of the converter?

- Extend the steady-state converter models of Chapters 2 and 3, to include CCM converter dynamics (Chapter 7)
- Construct converter small-signal transfer functions (Chapter 8)
- Design converter control systems (Chapter 9)
- Model converters operating in DCM (Chapter 10)
- Current-programmed control of converters (Chapter 11)

# Modeling

---

- Representation of physical behavior by mathematical means
- Model dominant behavior of system, ignore other insignificant phenomena
- Simplified model yields physical insight, allowing engineer to design system to operate in specified manner
- Approximations neglect small but complicating phenomena
- After basic insight has been gained, model can be refined (if it is judged worthwhile to expend the engineering effort to do so), to account for some of the previously neglected phenomena

# Neglecting the switching ripple

Suppose the duty cycle is modulated sinusoidally:

$$d(t) = D + D_m \cos \omega_m t$$

where  $D$  and  $D_m$  are constants,  $|D_m| \ll D$ , and the modulation frequency  $\omega_m$  is much smaller than the converter switching frequency  $\omega_s = 2\pi f_s$ .

The resulting variations in transistor gate drive signal and converter output voltage:

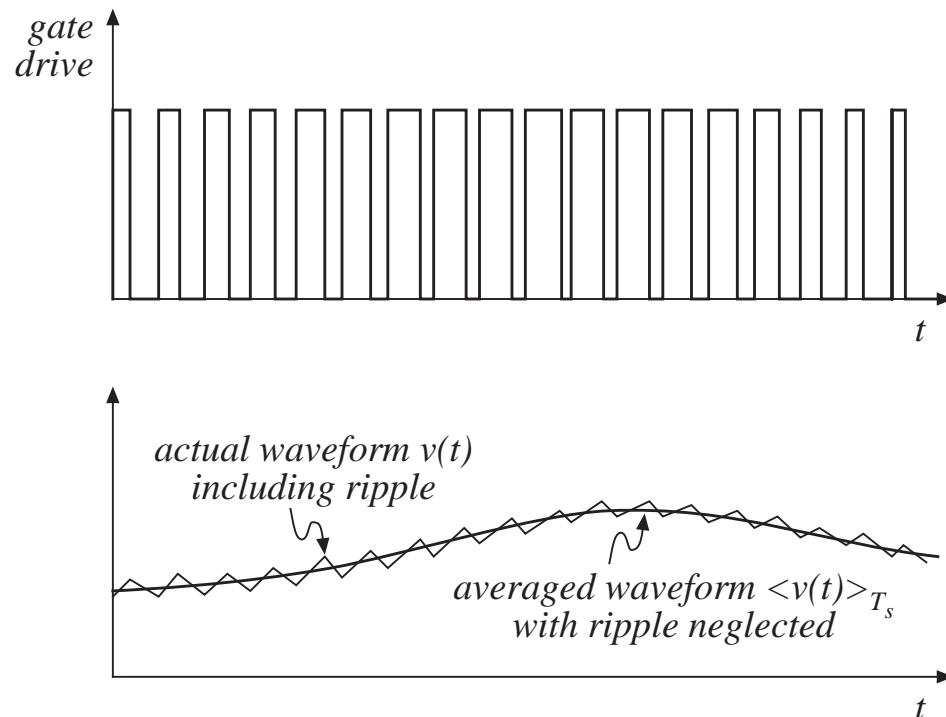

# Output voltage spectrum with sinusoidal modulation of duty cycle

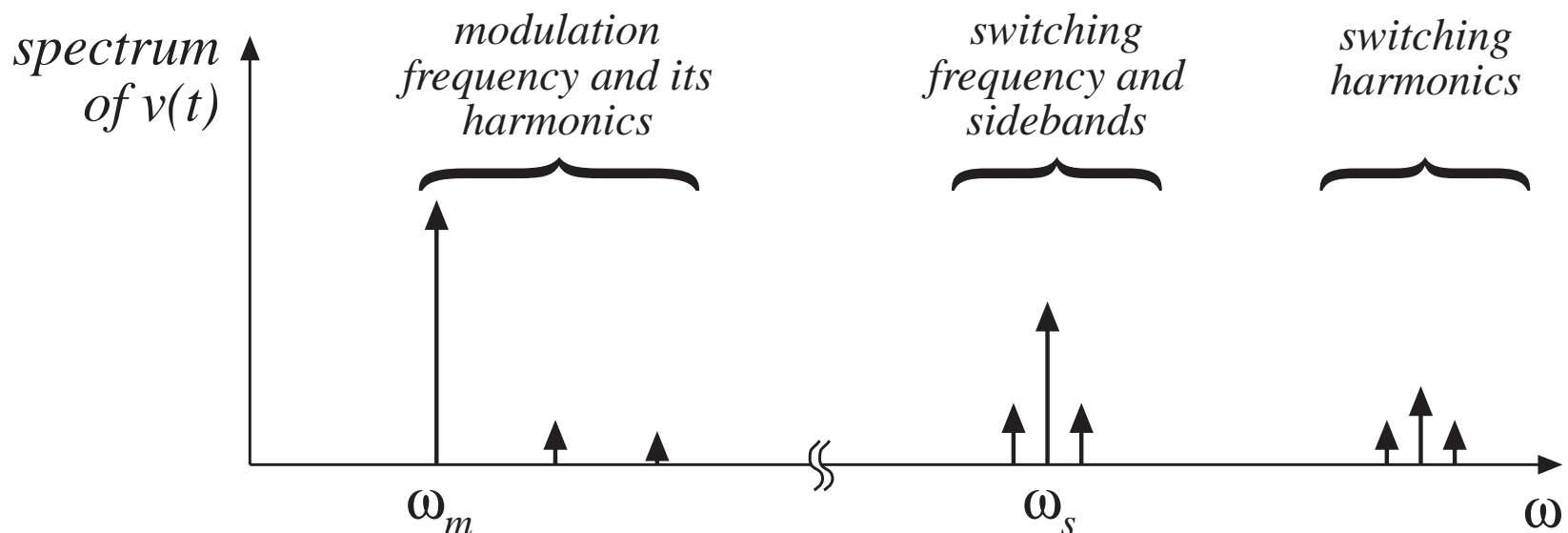

Contains frequency components at:

- Modulation frequency and its harmonics
- Switching frequency and its harmonics
- Sidebands of switching frequency

With small switching ripple, high-frequency components (switching harmonics and sidebands) are small.

If ripple is neglected, then only low-frequency components (modulation frequency and harmonics) remain.



# Objective of ac converter modeling

---

- Predict how low-frequency variations in duty cycle induce low-frequency variations in the converter voltages and currents
- Ignore the switching ripple
- Ignore complicated switching harmonics and sidebands

Approach:

- Remove switching harmonics by averaging all waveforms over one switching period

# Averaging to remove switching ripple

---

Average over one switching period to remove switching ripple:

$$L \frac{d\langle i_L(t) \rangle_{T_s}}{dt} = \langle v_L(t) \rangle_{T_s}$$

$$C \frac{d\langle v_C(t) \rangle_{T_s}}{dt} = \langle i_C(t) \rangle_{T_s}$$

where

$$\langle x_L(t) \rangle_{T_s} = \frac{1}{T_s} \int_t^{t+T_s} x(\tau) d\tau$$

Note that, in steady-state,

$$\langle v_L(t) \rangle_{T_s} = 0$$

$$\langle i_C(t) \rangle_{T_s} = 0$$

by inductor volt-second balance and capacitor charge balance.

# Nonlinear averaged equations

---

The averaged voltages and currents are, in general, nonlinear functions of the converter duty cycle, voltages, and currents. Hence, the averaged equations

$$L \frac{d\langle i_L(t) \rangle_{T_s}}{dt} = \langle v_L(t) \rangle_{T_s}$$
$$C \frac{d\langle v_C(t) \rangle_{T_s}}{dt} = \langle i_C(t) \rangle_{T_s}$$

constitute a system of nonlinear differential equations.

Hence, must linearize by constructing a small-signal converter model.

# Small-signal modeling of the BJT

Nonlinear Ebers-Moll model

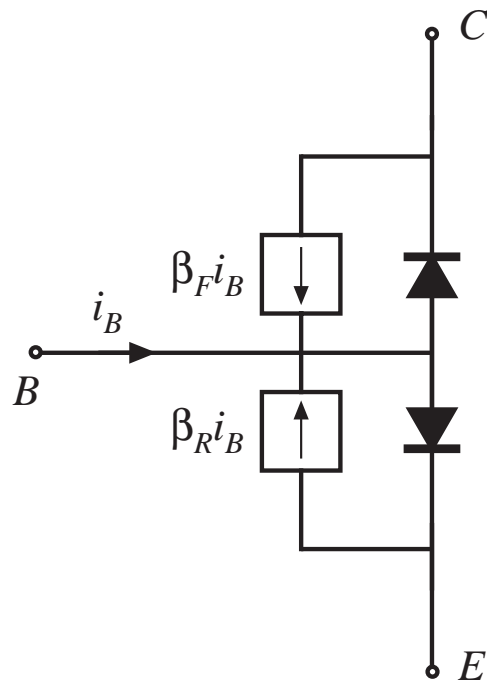

Linearized small-signal model, active region

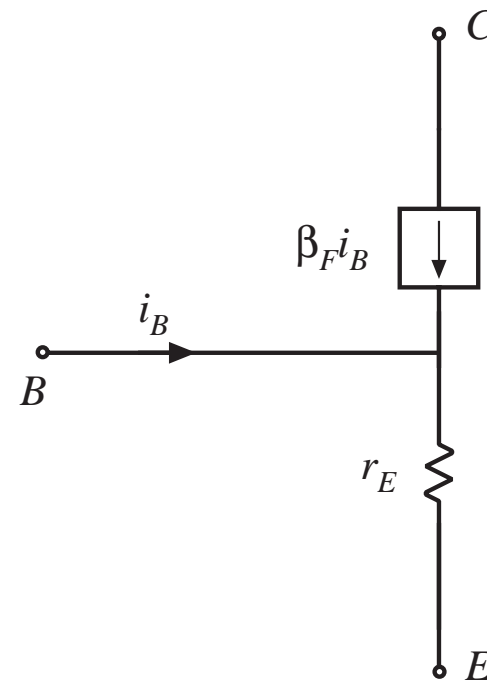

# Buck-boost converter: nonlinear static control-to-output characteristic

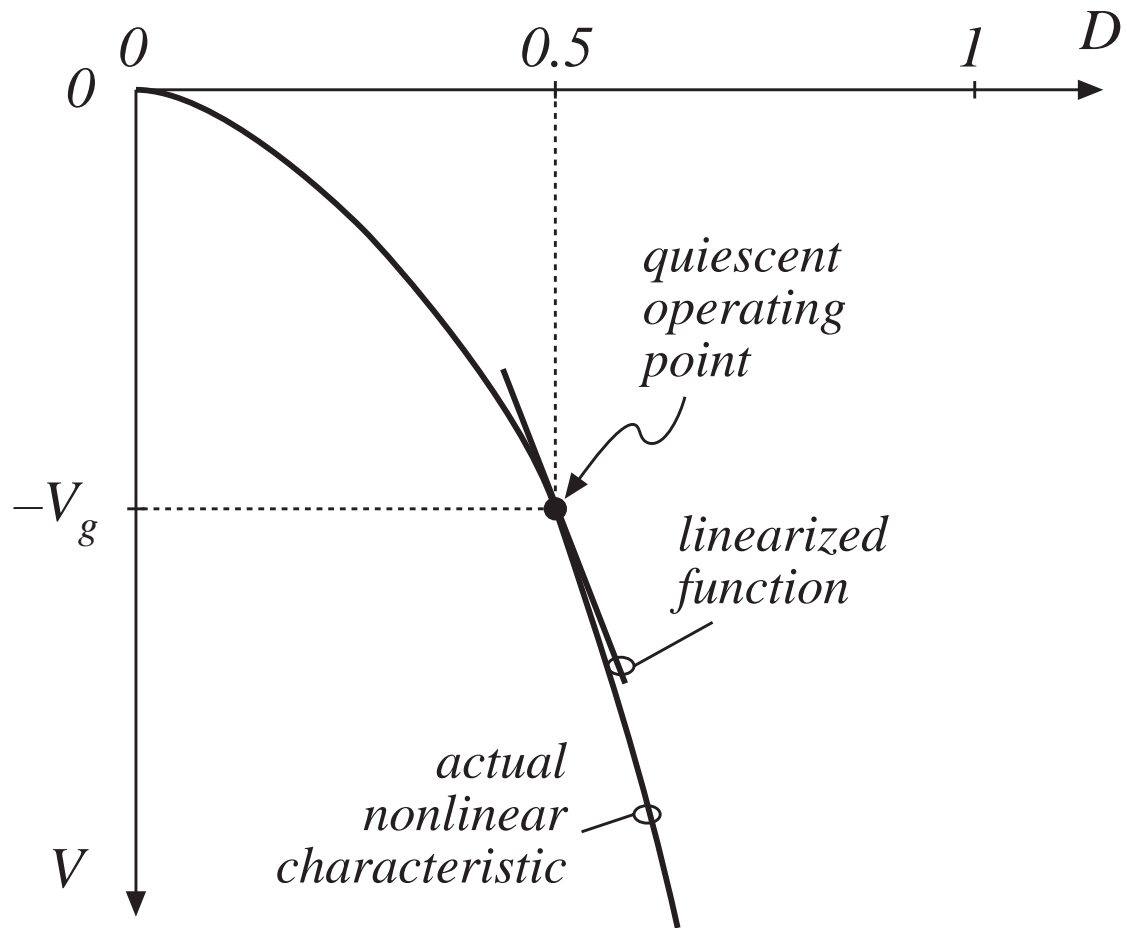

Example: linearization  
at the quiescent  
operating point

$$D = 0.5$$

# Result of averaged small-signal ac modeling

Small-signal ac equivalent circuit model

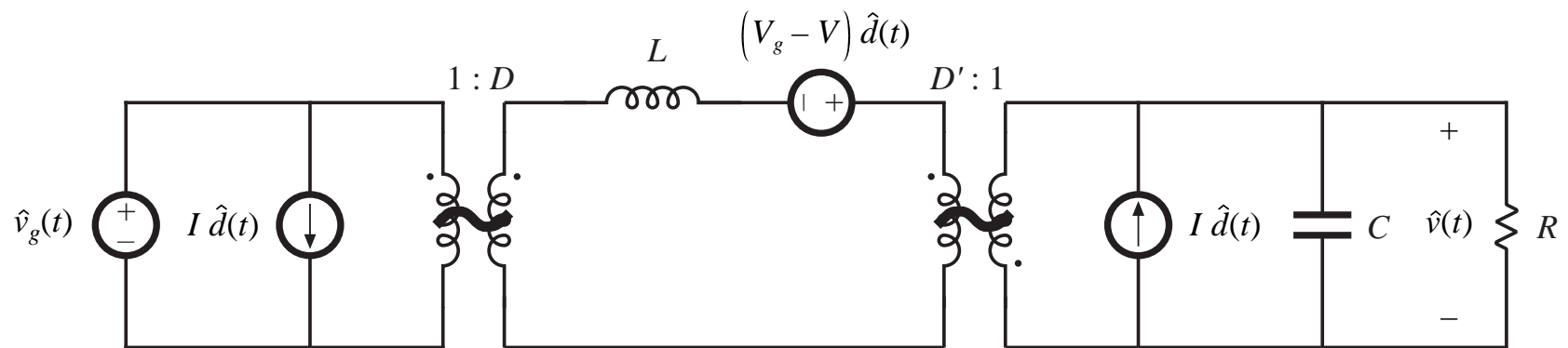

*buck-boost example*

## 7.2. The basic ac modeling approach

---

*Buck-boost converter example*

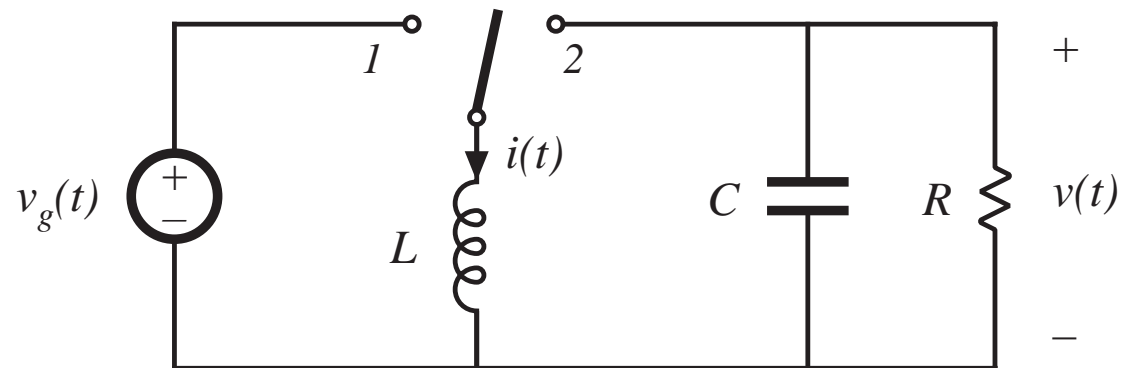

# Switch in position 1

Inductor voltage and capacitor current are:

$$v_L(t) = L \frac{di(t)}{dt} = v_g(t)$$

$$i_C(t) = C \frac{dv(t)}{dt} = -\frac{v(t)}{R}$$

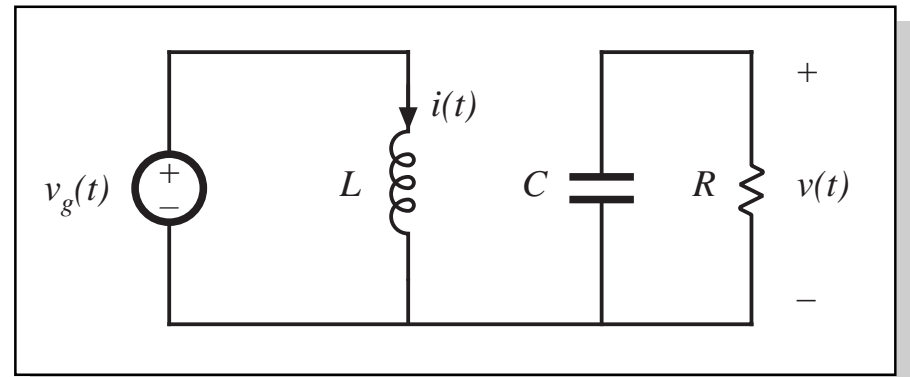

Small ripple approximation: replace waveforms with their low-frequency averaged values:

$$v_L(t) = L \frac{di(t)}{dt} \approx \langle v_g(t) \rangle_{T_s}$$

$$i_C(t) = C \frac{dv(t)}{dt} \approx -\frac{\langle v(t) \rangle_{T_s}}{R}$$



## Switch in position 2

Inductor voltage and capacitor current are:

$$v_L(t) = L \frac{di(t)}{dt} = v(t)$$

$$i_C(t) = C \frac{dv(t)}{dt} = -i(t) - \frac{v(t)}{R}$$

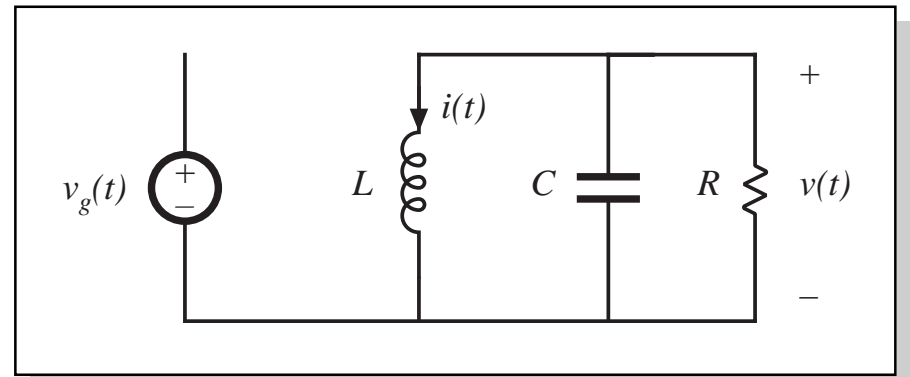

Small ripple approximation: replace waveforms with their low-frequency averaged values:

$$v_L(t) = L \frac{di(t)}{dt} \approx \langle v(t) \rangle_{T_s}$$

$$i_C(t) = C \frac{dv(t)}{dt} \approx -\langle i(t) \rangle_{T_s} - \frac{\langle v(t) \rangle_{T_s}}{R}$$

## 7.2.1 Averaging the inductor waveforms

### Inductor voltage waveform

Low-frequency average is found by evaluation of

$$\langle x_L(t) \rangle_{T_s} = \frac{1}{T_s} \int_t^{t+T_s} x(\tau) d\tau$$

Average the inductor voltage in this manner:

$$\langle v_L(t) \rangle_{T_s} = \frac{1}{T_s} \int_t^{t+T_s} v_L(\tau) d\tau \approx d(t) \langle v_g(t) \rangle_{T_s} + d'(t) \langle v(t) \rangle_{T_s}$$

Insert into Eq. (7.2):

$$L \frac{d\langle i(t) \rangle_{T_s}}{dt} = d(t) \langle v_g(t) \rangle_{T_s} + d'(t) \langle v(t) \rangle_{T_s}$$

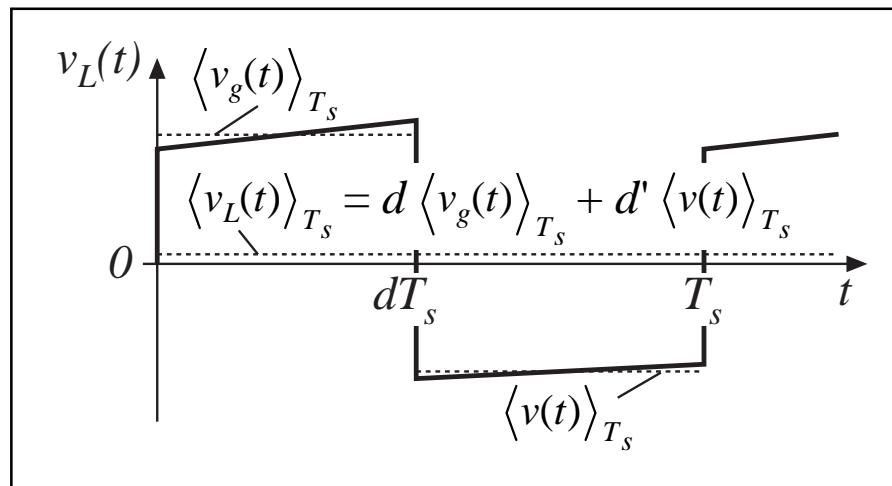

*This equation describes how the low-frequency components of the inductor waveforms evolve in time.*

## 7.2.2 Discussion of the averaging approximation

Use of the average inductor voltage allows us to determine the net change in inductor current over one switching period, while neglecting the switching ripple.

In steady-state, the average inductor voltage is zero (volt-second balance), and hence the inductor current waveform is periodic:  $i(t + T_s) = i(t)$ . There is no net change in inductor current over one switching period.

During transients or ac variations, the average inductor voltage is not zero in general, and this leads to net variations in inductor current.

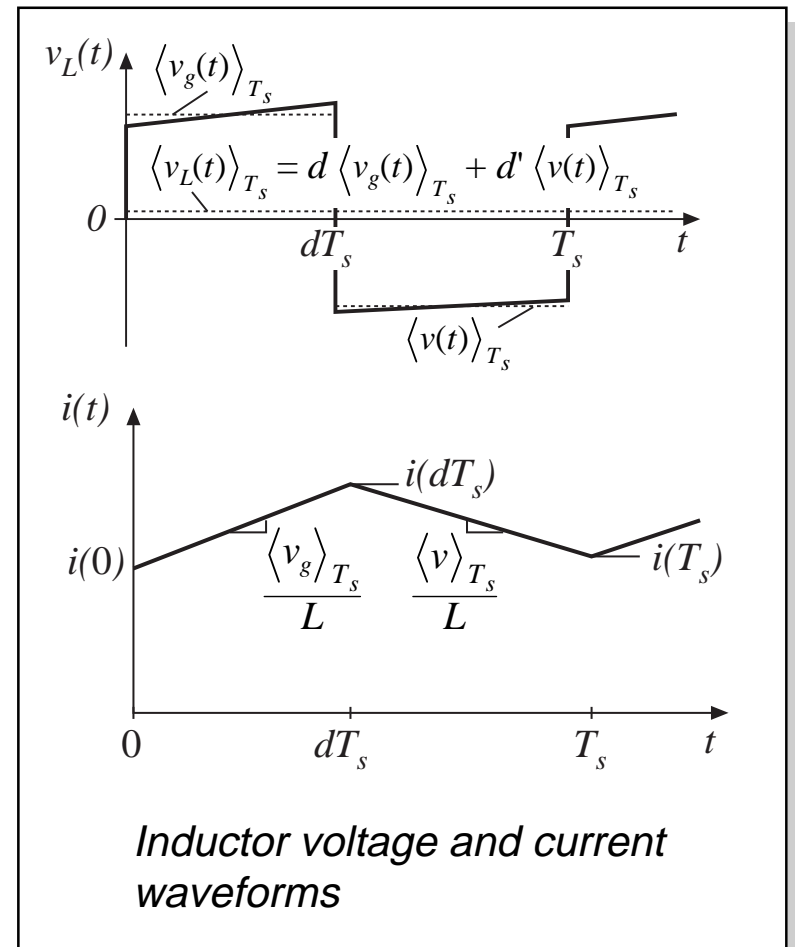

# Net change in inductor current is correctly predicted by the average inductor voltage

---

Inductor equation:

$$L \frac{di(t)}{dt} = v_L(t)$$

Divide by  $L$  and integrate over one switching period:

$$\int_t^{t+T_s} di = \frac{1}{L} \int_t^{t+T_s} v_L(\tau) d\tau$$

Left-hand side is the change in inductor current. Right-hand side can be related to average inductor voltage by multiplying and dividing by  $T_s$  as follows:

$$i(t + T_s) - i(t) = \frac{1}{L} T_s \langle v_L(t) \rangle_{T_s}$$

So the net change in inductor current over one switching period is exactly equal to the period  $T_s$  multiplied by the average slope  $\langle v_L \rangle_{T_s} / L$ .

# Average inductor voltage correctly predicts average slope of $i_L(t)$

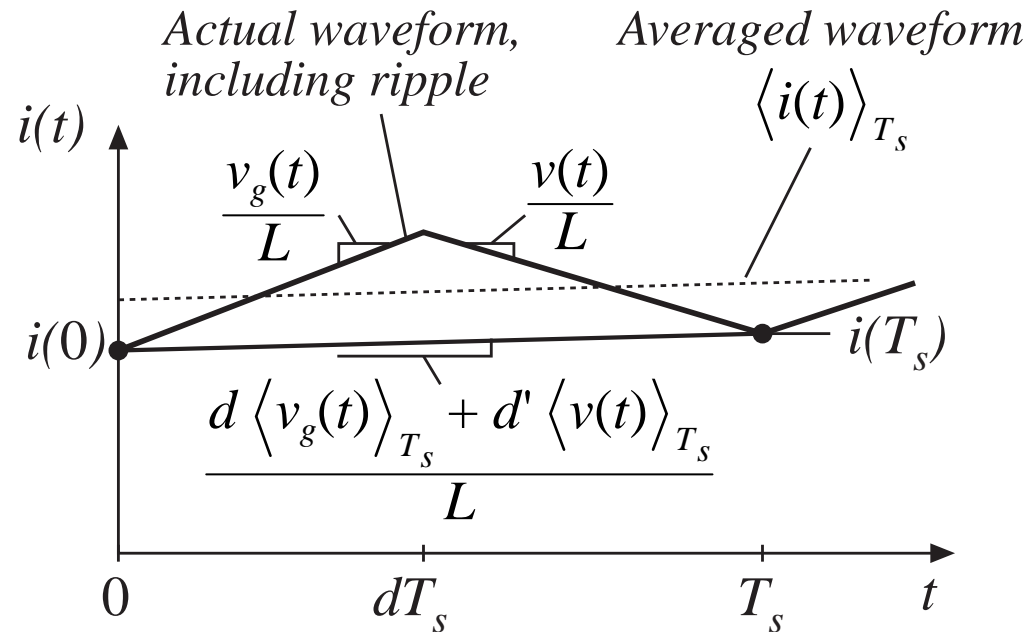

The net change in inductor current over one switching period is exactly equal to the period  $T_s$  multiplied by the average slope  $\langle v_L \rangle_{T_s} / L$ .

$$\frac{d\langle i(t) \rangle_{T_s}}{dt}$$

---

We have

$$i(t + T_s) - i(t) = \frac{1}{L} T_s \langle v_L(t) \rangle_{T_s}$$

Rearrange:

$$L \frac{i(t + T_s) - i(t)}{T_s} = \langle v_L(t) \rangle_{T_s}$$

Define the derivative of  $\langle i \rangle_{T_s}$  as (Euler formula):

$$\frac{d\langle i(t) \rangle_{T_s}}{dt} = \frac{i(t + T_s) - i(t)}{T_s}$$

Hence,

$$L \frac{d\langle i(t) \rangle_{T_s}}{dt} = \langle v_L(t) \rangle_{T_s}$$

# Computing how the inductor current changes over one switching period

Let's compute the actual inductor current waveform, using the linear ripple approximation.

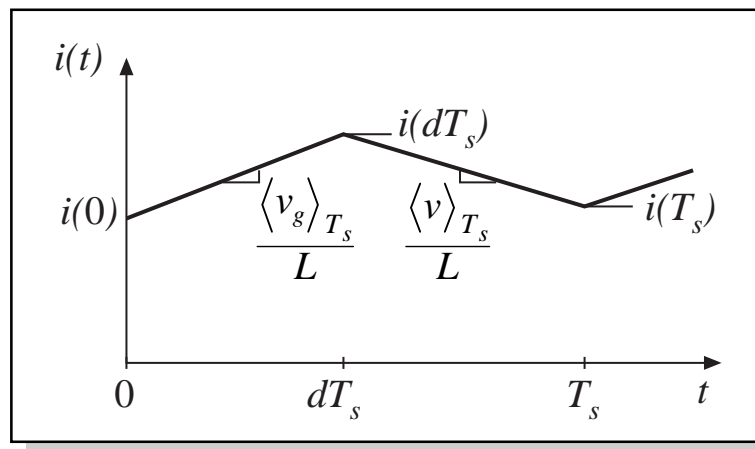

With switch in position 1:

$$\underbrace{i(dT_s)} = \underbrace{i(0)} + \underbrace{(dT_s)} \underbrace{\left( \frac{\langle v_g(t) \rangle_{T_s}}{L} \right)}$$

(final value) = (initial value) + (length of interval) (average slope)

With switch in position 2:

$$\underbrace{i(T_s)} = \underbrace{i(dT_s)} + \underbrace{(dT_s)} \underbrace{\left( \frac{\langle v(t) \rangle_{T_s}}{L} \right)}$$

(final value) = (initial value) + (length of interval) (average slope)

# Net change in inductor current over one switching period

Eliminate  $i(dT_s)$ , to express  $i(T_s)$  directly as a function of  $i(0)$ :

$$i(T_s) = i(0) + \frac{T_s}{L} \underbrace{\left( d \langle v_g(t) \rangle_{T_s} + d' \langle v(t) \rangle_{T_s} \right)}_{\langle v_L(t) \rangle_{T_s}}$$

The intermediate step of computing  $i(dT_s)$  is eliminated.

The final value  $i(T_s)$  is equal to the initial value  $i(0)$ , plus the switching period  $T_s$  multiplied by the average slope  $\langle v_L \rangle_{T_s} / L$ .

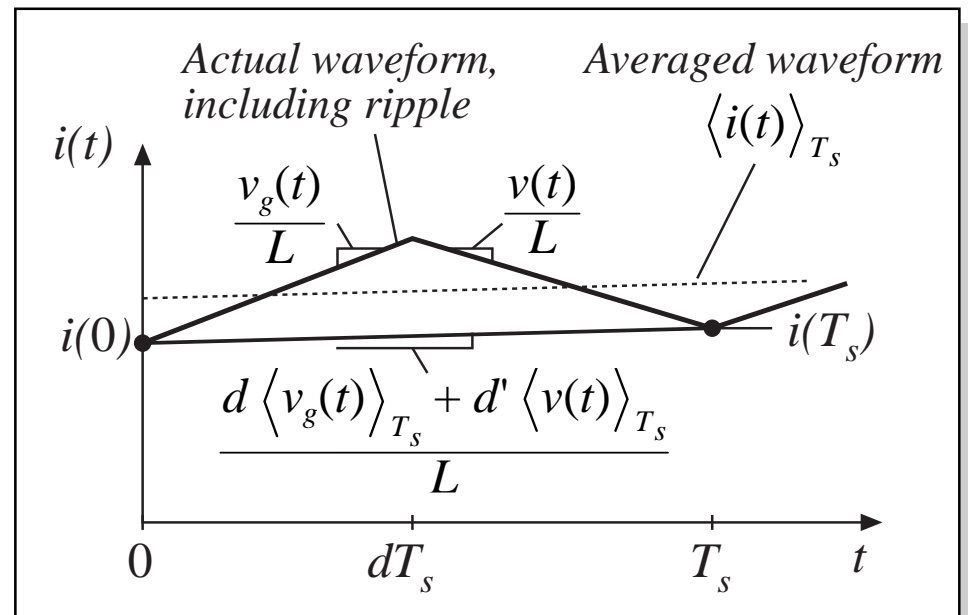



## 7.2.3 Averaging the capacitor waveforms

Average capacitor current:

$$\langle i_C(t) \rangle_{T_s} = d(t) \left( -\frac{\langle v(t) \rangle_{T_s}}{R} \right) + d'(t) \left( -\langle i(t) \rangle_{T_s} - \frac{\langle v(t) \rangle_{T_s}}{R} \right)$$

Collect terms, and equate to  $C d\langle v \rangle_{T_s} / dt$ :

$$C \frac{d\langle v(t) \rangle_{T_s}}{dt} = -d'(t) \langle i(t) \rangle_{T_s} - \frac{\langle v(t) \rangle_{T_s}}{R}$$

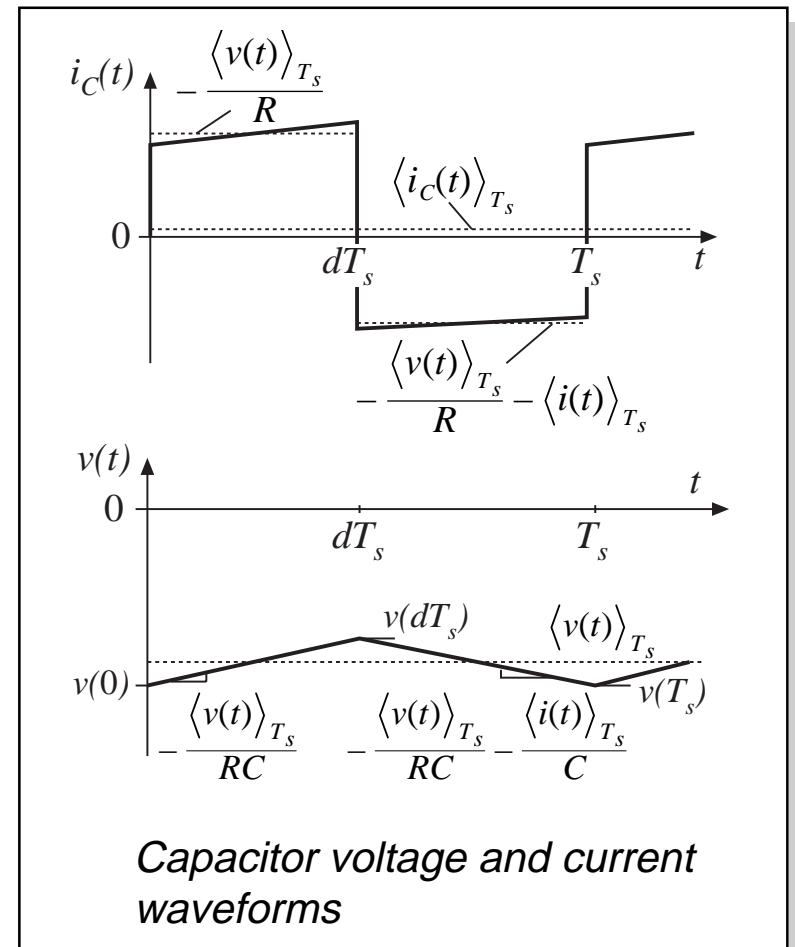

## 7.2.4 The average input current

We found in Chapter 3 that it was sometimes necessary to write an equation for the average converter input current, to derive a complete dc equivalent circuit model. It is likewise necessary to do this for the ac model.

Buck-boost input current waveform is

$$i_g(t) = \begin{cases} \langle i(t) \rangle_{T_s} & \text{during subinterval 1} \\ 0 & \text{during subinterval 2} \end{cases}$$

Average value:

$$\langle i_g(t) \rangle_{T_s} = d(t) \langle i(t) \rangle_{T_s}$$

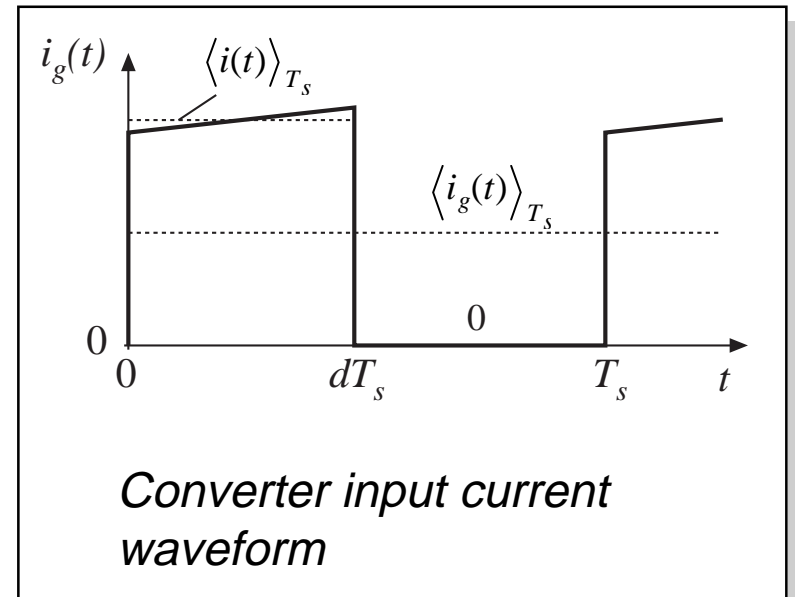

## 7.2.5. Perturbation and linearization

---

Converter averaged equations:

$$L \frac{d\langle i(t) \rangle_{T_s}}{dt} = d(t) \langle v_g(t) \rangle_{T_s} + d'(t) \langle v(t) \rangle_{T_s}$$
$$C \frac{d\langle v(t) \rangle_{T_s}}{dt} = -d'(t) \langle i(t) \rangle_{T_s} - \frac{\langle v(t) \rangle_{T_s}}{R}$$
$$\langle i_g(t) \rangle_{T_s} = d(t) \langle i(t) \rangle_{T_s}$$

—nonlinear because of multiplication of the time-varying quantity  $d(t)$  with other time-varying quantities such as  $i(t)$  and  $v(t)$ .

# Construct small-signal model: Linearize about quiescent operating point

---

If the converter is driven with some steady-state, or quiescent, inputs

$$d(t) = D$$
$$\langle v_g(t) \rangle_{T_s} = V_g$$

then, from the analysis of Chapter 2, after transients have subsided the inductor current, capacitor voltage, and input current

$$\langle i(t) \rangle_{T_s}, \langle v(t) \rangle_{T_s}, \langle i_g(t) \rangle_{T_s}$$

reach the quiescent values  $I$ ,  $V$ , and  $I_g$ , given by the steady-state analysis as

$$V = -\frac{D}{D'} V_g$$
$$I = -\frac{V}{D' R}$$
$$I_g = D I$$

# Perturbation

---

So let us assume that the input voltage and duty cycle are equal to some given (dc) quiescent values, plus superimposed small ac variations:

$$\begin{aligned}\langle v_g(t) \rangle_{T_s} &= V_g + \hat{v}_g(t) \\ d(t) &= D + \hat{d}(t)\end{aligned}$$

In response, and after any transients have subsided, the converter dependent voltages and currents will be equal to the corresponding quiescent values, plus small ac variations:

$$\begin{aligned}\langle i(t) \rangle_{T_s} &= I + \hat{i}(t) \\ \langle v(t) \rangle_{T_s} &= V + \hat{v}(t) \\ \langle i_g(t) \rangle_{T_s} &= I_g + \hat{i}_g(t)\end{aligned}$$

# The small-signal assumption

---

If the ac variations are much smaller in magnitude than the respective quiescent values,

$$|\hat{v}_g(t)| \ll |V_g|$$

$$|\hat{d}(t)| \ll |D|$$

$$|\hat{i}(t)| \ll |I|$$

$$|\hat{v}(t)| \ll |V|$$

$$|\hat{i}_g(t)| \ll |I_g|$$

then the nonlinear converter equations can be linearized.

# Perturbation of inductor equation

Insert the perturbed expressions into the inductor differential equation:

$$L \frac{d(I + \hat{i}(t))}{dt} = (D + \hat{d}(t)) (V_g + \hat{v}_g(t)) + (D' - \hat{d}(t)) (V + \hat{v}(t))$$

note that  $d'(t)$  is given by

$$d'(t) = (1 - d(t)) = 1 - (D + \hat{d}(t)) = D' - \hat{d}(t) \quad \text{with } D' = 1 - D$$

Multiply out and collect terms:

$$L \left( \frac{dI}{dt} + \frac{d\hat{i}(t)}{dt} \right) = \underbrace{(DV_g + D'V)}_{Dc \text{ terms}} + \underbrace{\left( D\hat{v}_g(t) + D'\hat{v}(t) + (V_g - V)\hat{d}(t) \right)}_{1^{st} \text{ order ac terms (linear)}} + \underbrace{\hat{d}(t) (\hat{v}_g(t) - \hat{v}(t))}_{2^{nd} \text{ order ac terms (nonlinear)}}$$

# The perturbed inductor equation

$$L \left( \frac{dI}{dt} + \frac{d\hat{i}(t)}{dt} \right) = \underbrace{(DV_g + D'V)}_{\text{Dc terms}} + \underbrace{\left( D\hat{v}_g(t) + D'\hat{v}(t) + (V_g - V) \hat{d}(t) \right)}_{\substack{1^{\text{st}} \text{ order ac terms} \\ \text{(linear)}}} + \underbrace{\hat{d}(t) (\hat{v}_g(t) - \hat{v}(t))}_{\substack{2^{\text{nd}} \text{ order ac terms} \\ \text{(nonlinear)}}$$

Since  $I$  is a constant (dc) term, its derivative is zero

The right-hand side contains three types of terms:

- Dc terms, containing only dc quantities
- First-order ac terms, containing a single ac quantity, usually multiplied by a constant coefficient such as a dc term. These are linear functions of the ac variations
- Second-order ac terms, containing products of ac quantities. These are nonlinear, because they involve multiplication of ac quantities



# Neglect of second-order terms

$$L \left( \frac{d\mathbf{I}^0}{dt} + \frac{d\hat{i}(t)}{dt} \right) = \underbrace{(DV_g + D'V)}_{\text{Dc terms}} + \underbrace{\left( D\hat{v}_g(t) + D'\hat{v}(t) + (V_g - V)\hat{d}(t) \right)}_{\substack{1^{\text{st}} \text{ order ac terms} \\ \text{(linear)}}} + \underbrace{\hat{d}(t) (\hat{v}_g(t) - \hat{v}(t))}_{\substack{2^{\text{nd}} \text{ order ac terms} \\ \text{(nonlinear)}}$$

Provided

$$\begin{aligned} |\hat{v}_g(t)| &\ll |V_g| \\ |\hat{d}(t)| &\ll |D| \\ |\hat{i}(t)| &\ll |I| \\ |\hat{v}(t)| &\ll |V| \\ |\hat{i}_g(t)| &\ll |I_g| \end{aligned}$$

then the second-order ac terms are much smaller than the first-order terms. For example,

$$|\hat{d}(t) \hat{v}_g(t)| \ll |D \hat{v}_g(t)| \quad \text{when} \quad |\hat{d}(t)| \ll D$$

So neglect second-order terms.

Also, dc terms on each side of equation are equal.

# Linearized inductor equation

---

Upon discarding second-order terms, and removing dc terms (which add to zero), we are left with

$$L \frac{d\hat{i}(t)}{dt} = D\hat{v}_g(t) + D'\hat{v}(t) + (V_g - V)\hat{d}(t)$$

This is the desired result: a linearized equation which describes small-signal ac variations.

Note that the quiescent values  $D$ ,  $D'$ ,  $V$ ,  $V_g$ , are treated as given constants in the equation.

# Capacitor equation

Perturbation leads to

$$C \frac{d(V + \hat{v}(t))}{dt} = - (D' - \hat{d}(t)) (I + \hat{i}(t)) - \frac{(V + \hat{v}(t))}{R}$$

Collect terms:

$$C \left( \frac{dV}{dt} + \frac{d\hat{v}(t)}{dt} \right) = \underbrace{\left( -D'I - \frac{V}{R} \right)}_{\text{Dc terms}} + \underbrace{\left( -D'\hat{i}(t) - \frac{\hat{v}(t)}{R} + I\hat{d}(t) \right)}_{\substack{1^{\text{st}} \text{ order ac terms} \\ \text{(linear)}}} + \underbrace{\hat{d}(t)\hat{i}(t)}_{\substack{2^{\text{nd}} \text{ order ac term} \\ \text{(nonlinear)}}$$

Neglect second-order terms. Dc terms on both sides of equation are equal. The following terms remain:

$$C \frac{d\hat{v}(t)}{dt} = -D'\hat{i}(t) - \frac{\hat{v}(t)}{R} + I\hat{d}(t)$$

This is the desired small-signal linearized capacitor equation.

# Average input current

---

Perturbation leads to

$$I_g + \hat{i}_g(t) = (D + \hat{d}(t)) (I + \hat{i}(t))$$

Collect terms:

$$\underbrace{I_g}_{\text{Dc term}} + \underbrace{\hat{i}_g(t)}_{1^{\text{st}} \text{ order ac term}} = \underbrace{(DI)}_{\text{Dc term}} + \underbrace{(D\hat{i}(t) + I\hat{d}(t))}_{1^{\text{st}} \text{ order ac terms (linear)}} + \underbrace{\hat{d}(t)\hat{i}(t)}_{2^{\text{nd}} \text{ order ac term (nonlinear)}}$$

Neglect second-order terms. Dc terms on both sides of equation are equal. The following first-order terms remain:

$$\hat{i}_g(t) = D\hat{i}(t) + I\hat{d}(t)$$

This is the linearized small-signal equation which described the converter input port.

## 7.2.6. Construction of small-signal equivalent circuit model

---

The linearized small-signal converter equations:

$$L \frac{d\hat{i}(t)}{dt} = D\hat{v}_g(t) + D'\hat{v}(t) + (V_g - V) \hat{d}(t)$$

$$C \frac{d\hat{v}(t)}{dt} = -D'\hat{i}(t) - \frac{\hat{v}(t)}{R} + I\hat{d}(t)$$

$$\hat{i}_g(t) = D\hat{i}(t) + I\hat{d}(t)$$

Reconstruct equivalent circuit corresponding to these equations, in manner similar to the process used in Chapter 3.

# Inductor loop equation

---

$$L \frac{d\hat{i}(t)}{dt} = D\hat{v}_g(t) + D'\hat{v}(t) + (V_g - V) \hat{d}(t)$$

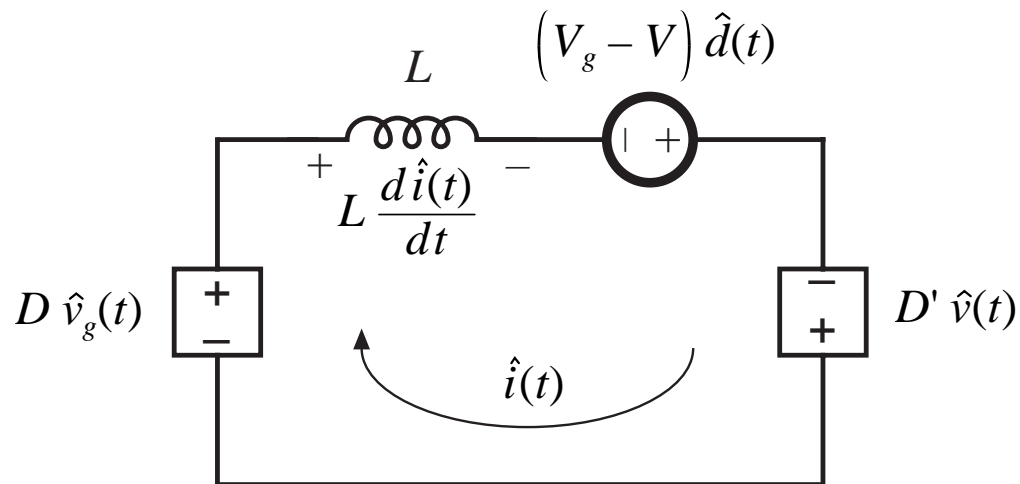

# Capacitor node equation

---

$$C \frac{d\hat{v}(t)}{dt} = -D' \hat{i}(t) - \frac{\hat{v}(t)}{R} + I \hat{d}(t)$$

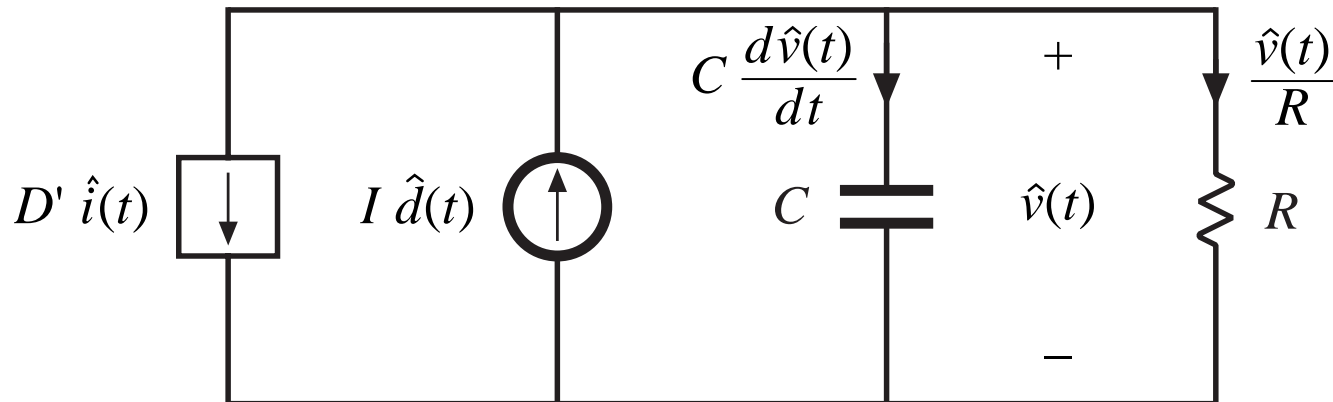

# Input port node equation

---

$$\hat{i}_g(t) = D\hat{i}(t) + I\hat{d}(t)$$

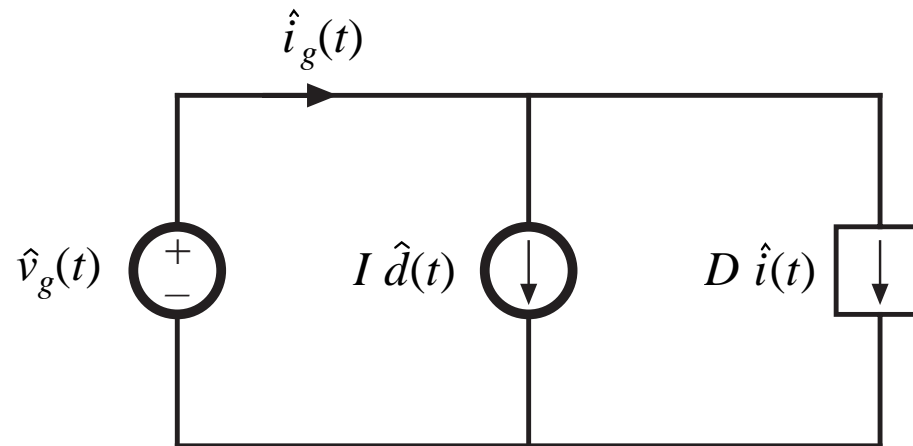



# Complete equivalent circuit

Collect the three circuits:

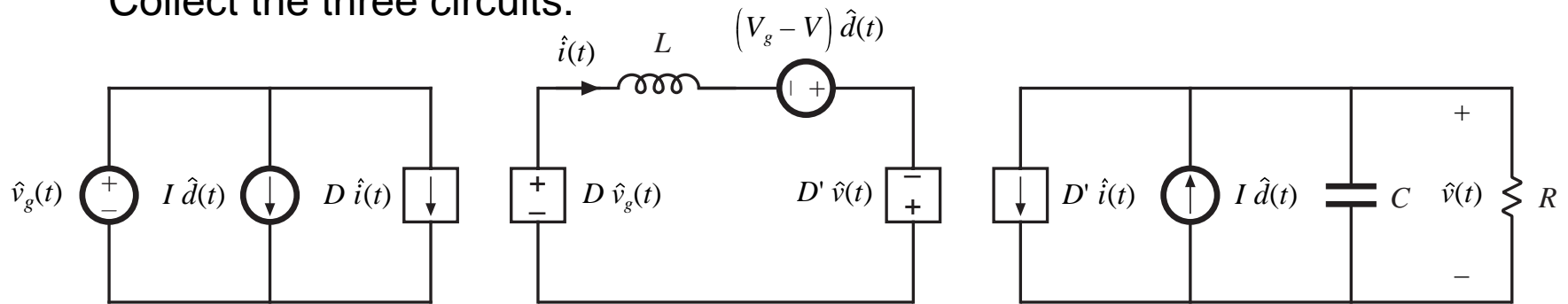

Replace dependent sources with ideal dc transformers:

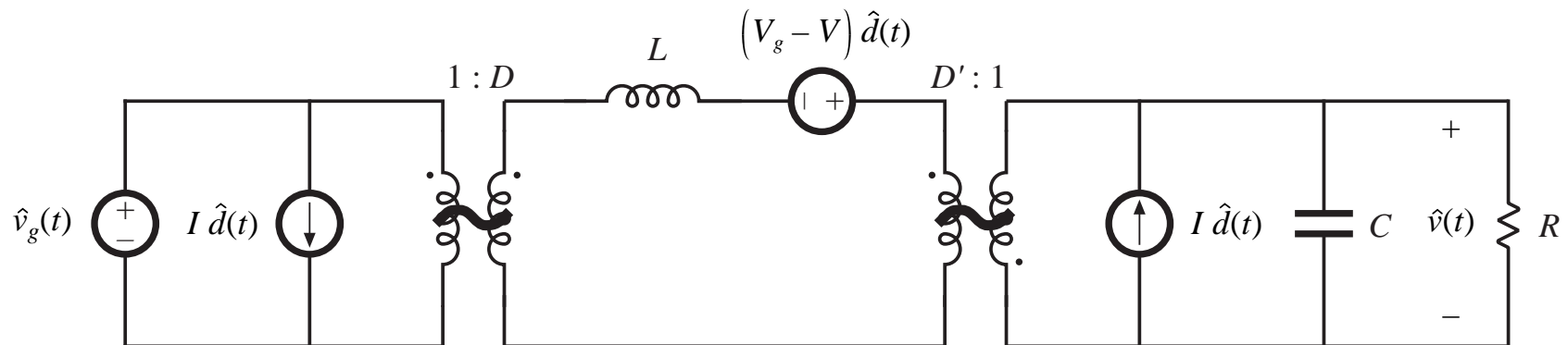

Small-signal ac equivalent circuit model of the buck-boost converter

## 7.2.7. Results for several basic converters

*buck*

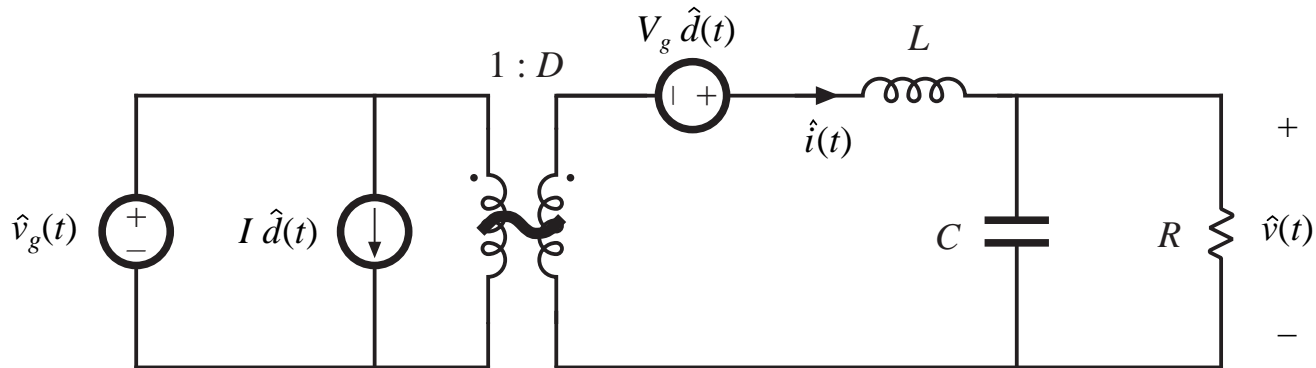

*boost*

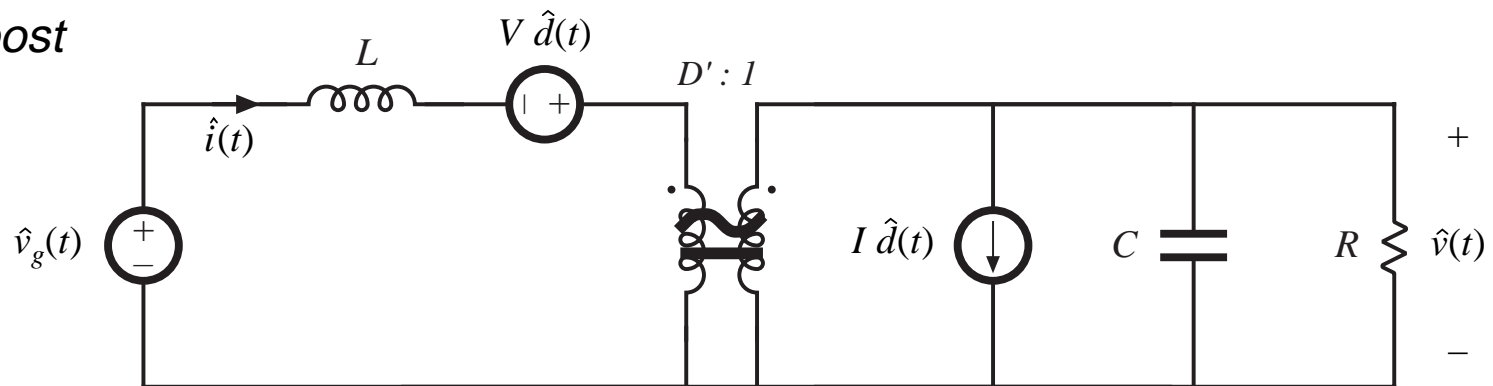

# Results for several basic converters

*buck-boost*

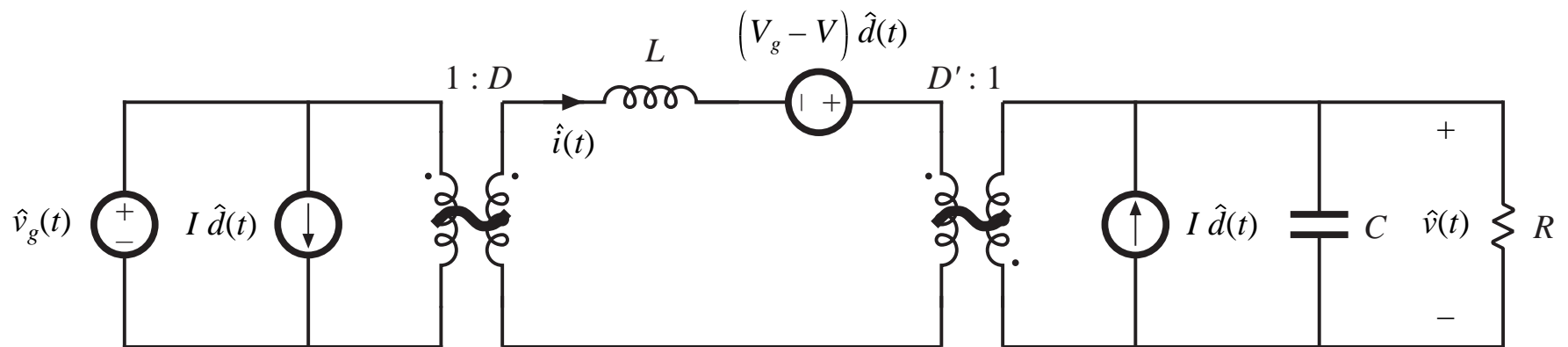

## 7.3. Example: a nonideal flyback converter

*Flyback converter example*

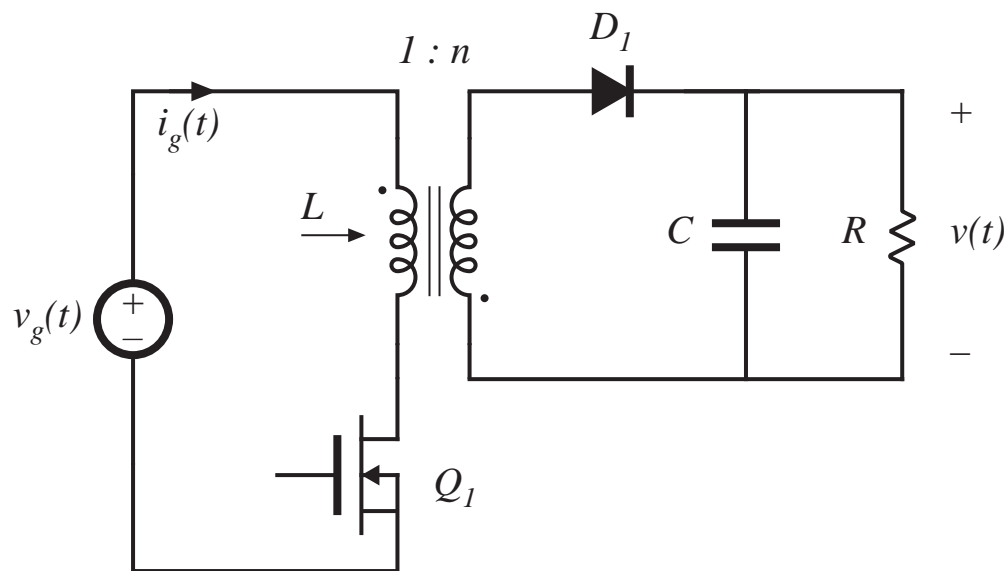

- MOSFET has on-resistance  $R_{on}$
- Flyback transformer has magnetizing inductance  $L$ , referred to primary

# Circuits during subintervals 1 and 2

*Flyback converter, with transformer equivalent circuit*

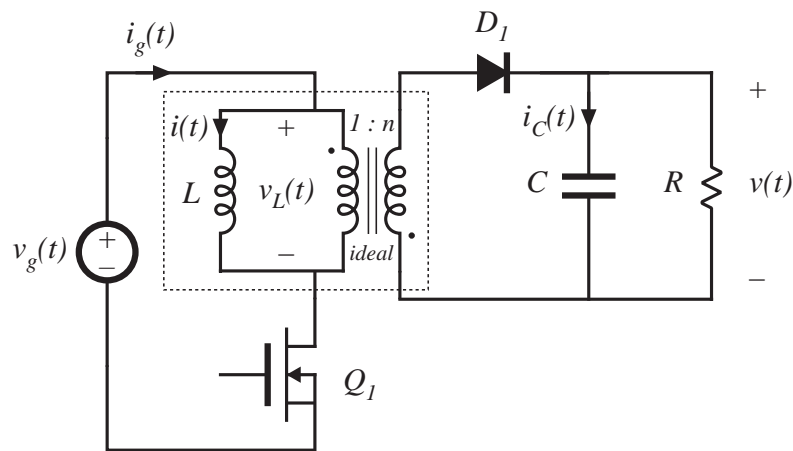

*Subinterval 1*

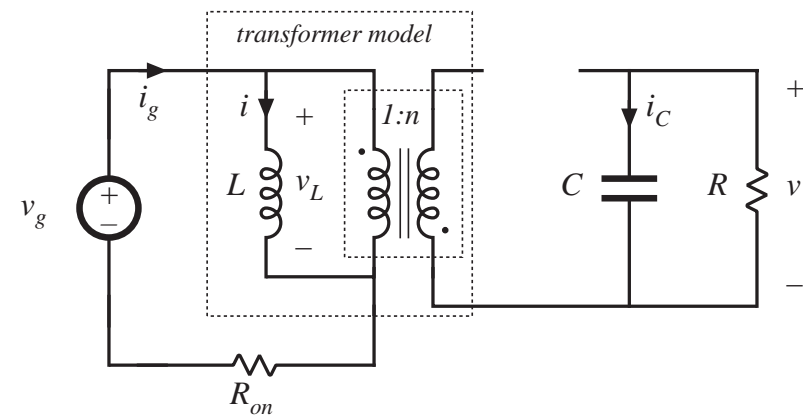

*Subinterval 2*

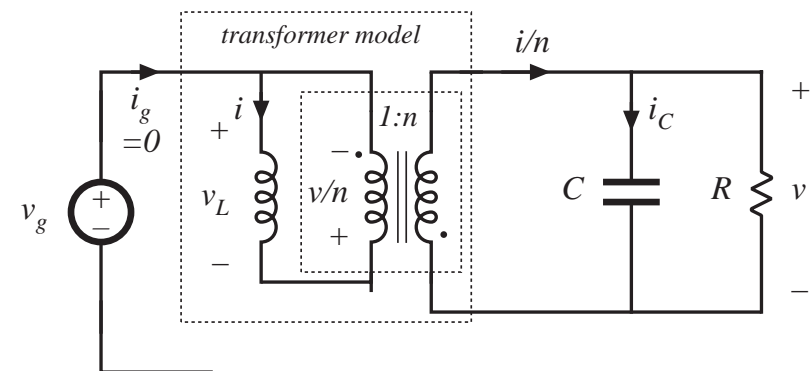

# Subinterval 1

Circuit equations:

$$v_L(t) = v_g(t) - i(t) R_{on}$$

$$i_C(t) = -\frac{v(t)}{R}$$

$$i_g(t) = i(t)$$

Small ripple approximation:

$$v_L(t) = \langle v_g(t) \rangle_{T_s} - \langle i(t) \rangle_{T_s} R_{on}$$

$$i_C(t) = -\frac{\langle v(t) \rangle_{T_s}}{R}$$

$$i_g(t) = \langle i(t) \rangle_{T_s}$$

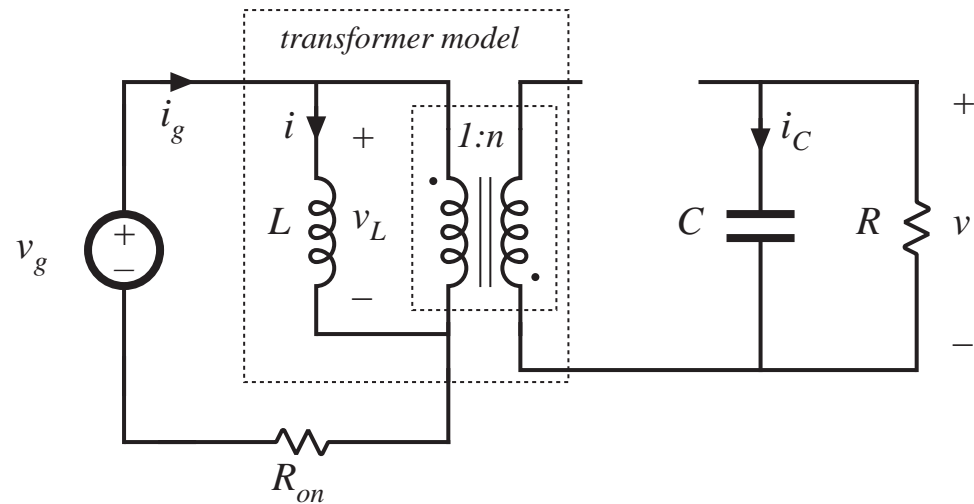

MOSFET conducts, diode is reverse-biased

## Subinterval 2

Circuit equations:

$$v_L(t) = -\frac{v(t)}{n}$$

$$i_C(t) = -\frac{i(t)}{n} - \frac{v(t)}{R}$$

$$i_g(t) = 0$$

Small ripple approximation:

$$v_L(t) = -\frac{\langle v(t) \rangle_{T_s}}{n}$$

$$i_C(t) = -\frac{\langle i(t) \rangle_{T_s}}{n} - \frac{\langle v(t) \rangle_{T_s}}{R}$$

$$i_g(t) = 0$$

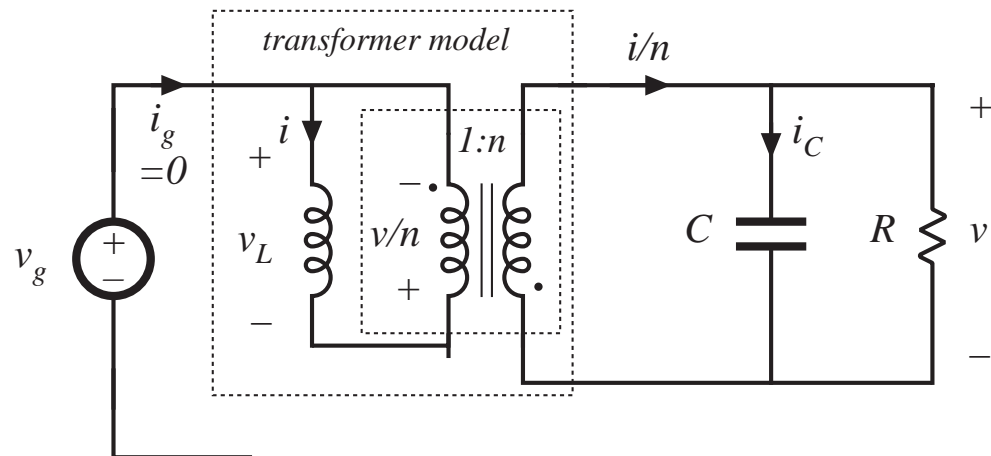

MOSFET is off, diode conducts

# Inductor waveforms

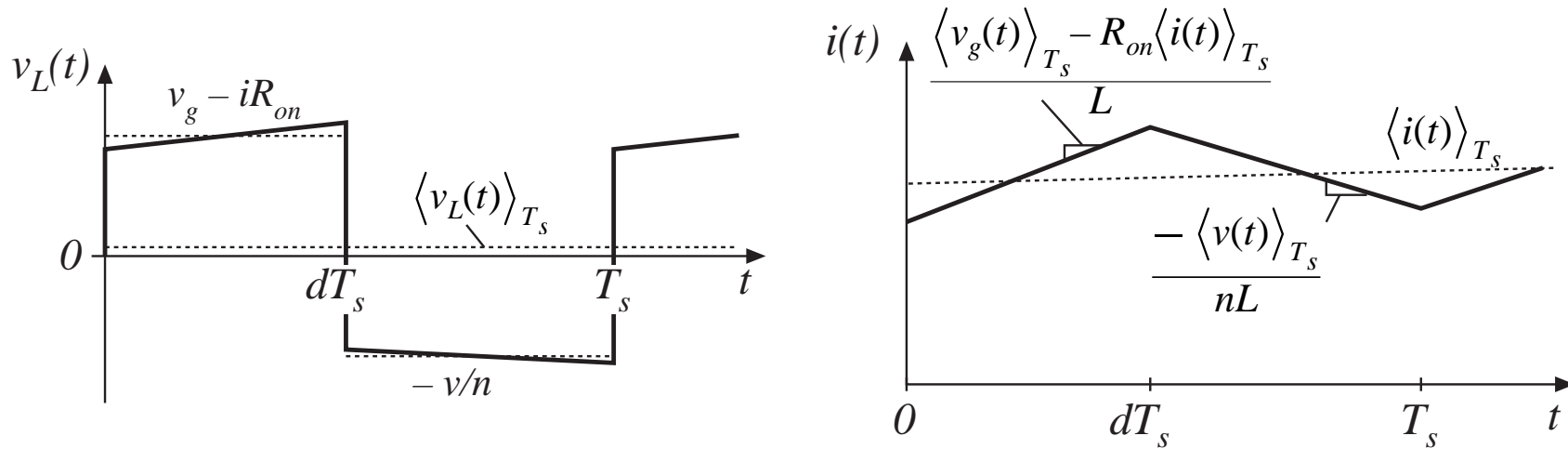

Average inductor voltage:

$$\langle v_L(t) \rangle_{T_s} = d(t) \left( \langle v_g(t) \rangle_{T_s} - \langle i(t) \rangle_{T_s} R_{on} \right) + d'(t) \left( \frac{-\langle v(t) \rangle_{T_s}}{n} \right)$$

Hence, we can write:

$$L \frac{d\langle i(t) \rangle_{T_s}}{dt} = d(t) \langle v_g(t) \rangle_{T_s} - d(t) \langle i(t) \rangle_{T_s} R_{on} - d'(t) \frac{\langle v(t) \rangle_{T_s}}{n}$$



# Capacitor waveforms

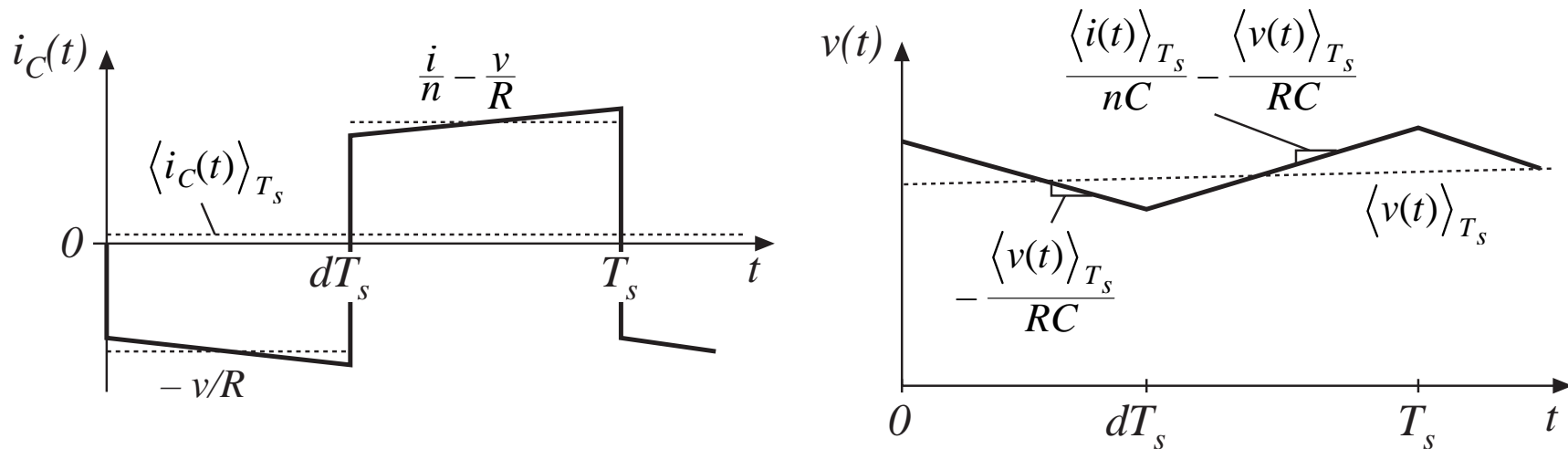

Average capacitor current:

$$\langle i_C(t) \rangle_{T_s} = d(t) \left( -\frac{\langle v(t) \rangle_{T_s}}{R} \right) + d'(t) \left( \frac{\langle i(t) \rangle_{T_s}}{n} - \frac{\langle v(t) \rangle_{T_s}}{R} \right)$$

Hence, we can write:

$$C \frac{d\langle v(t) \rangle_{T_s}}{dt} = d'(t) \frac{\langle i(t) \rangle_{T_s}}{n} - \frac{\langle v(t) \rangle_{T_s}}{R}$$

# Input current waveform

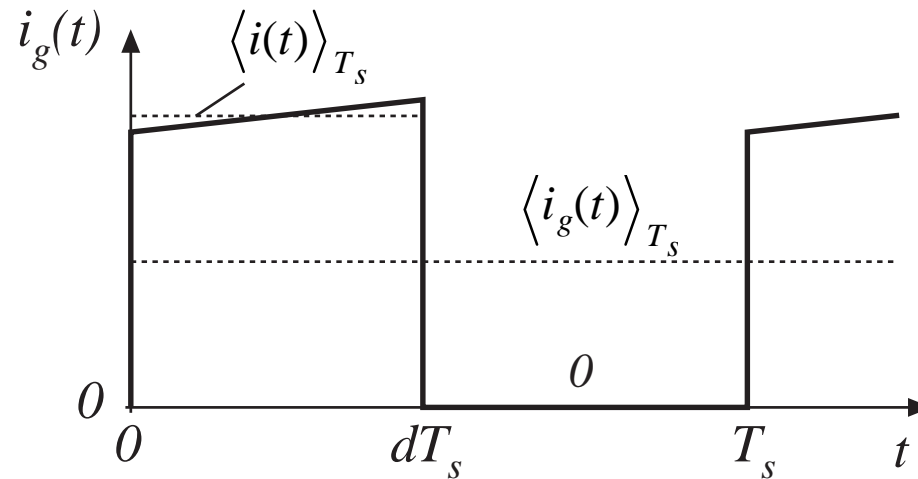

Average input current:

$$\langle i_g(t) \rangle_{T_s} = d(t) \langle i(t) \rangle_{T_s}$$

# The averaged converter equations

---

$$\begin{aligned}L \frac{d\langle i(t) \rangle_{T_s}}{dt} &= d(t) \langle v_g(t) \rangle_{T_s} - d(t) \langle i(t) \rangle_{T_s} R_{on} - d'(t) \frac{\langle v(t) \rangle_{T_s}}{n} \\C \frac{d\langle v(t) \rangle_{T_s}}{dt} &= d'(t) \frac{\langle i(t) \rangle_{T_s}}{n} - \frac{\langle v(t) \rangle_{T_s}}{R} \\ \langle i_g(t) \rangle_{T_s} &= d(t) \langle i(t) \rangle_{T_s}\end{aligned}$$

— a system of nonlinear differential equations

Next step: perturbation and linearization. Let

$$\begin{aligned}\langle v_g(t) \rangle_{T_s} &= V_g + \hat{v}_g(t) & \langle i(t) \rangle_{T_s} &= I + \hat{i}(t) \\ d(t) &= D + \hat{d}(t) & \langle v(t) \rangle_{T_s} &= V + \hat{v}(t) \\ & & \langle i_g(t) \rangle_{T_s} &= I_g + \hat{i}_g(t)\end{aligned}$$

# Perturbation of the averaged inductor equation

$$L \frac{d\langle i(t) \rangle_{T_s}}{dt} = d(t) \langle v_g(t) \rangle_{T_s} - d(t) \langle i(t) \rangle_{T_s} R_{on} - d'(t) \frac{\langle v(t) \rangle_{T_s}}{n}$$

$$L \frac{d(I + \hat{i}(t))}{dt} = (D + \hat{d}(t)) (V_g + \hat{v}_g(t)) - (D' - \hat{d}(t)) \frac{(V + \hat{v}(t))}{n} - (D + \hat{d}(t)) (I + \hat{i}(t)) R_{on}$$

$$L \left( \frac{I^0}{dt} + \frac{d\hat{i}(t)}{dt} \right) = \underbrace{\left( DV_g - D' \frac{V}{n} - DR_{on}I \right)}_{Dc \text{ terms}} + \underbrace{\left( D\hat{v}_g(t) - D' \frac{\hat{v}(t)}{n} + \left( V_g + \frac{V}{n} - IR_{on} \right) \hat{d}(t) - DR_{on}\hat{i}(t) \right)}_{1^{st} \text{ order ac terms (linear)}} + \underbrace{\left( \hat{d}(t)\hat{v}_g(t) + \hat{d}(t)\frac{\hat{v}(t)}{n} - \hat{d}(t)\hat{i}(t)R_{on} \right)}_{2^{nd} \text{ order ac terms (nonlinear)}}$$

# Linearization of averaged inductor equation

---

Dc terms:

$$0 = DV_g - D'\frac{V}{n} - DR_{on}I$$

Second-order terms are small when the small-signal assumption is satisfied. The remaining first-order terms are:

$$L \frac{d\hat{i}(t)}{dt} = D\hat{v}_g(t) - D'\frac{\hat{v}(t)}{n} + \left( V_g + \frac{V}{n} - IR_{on} \right) \hat{d}(t) - DR_{on}\hat{i}(t)$$

This is the desired linearized inductor equation.

# Perturbation of averaged capacitor equation

Original averaged equation:

$$C \frac{d\langle v(t) \rangle_{T_s}}{dt} = d'(t) \frac{\langle i(t) \rangle_{T_s}}{n} - \frac{\langle v(t) \rangle_{T_s}}{R}$$

Perturb about quiescent operating point:

$$C \frac{d(V + \hat{v}(t))}{dt} = (D' - \hat{d}(t)) \frac{(I + \hat{i}(t))}{n} - \frac{(V + \hat{v}(t))}{R}$$

Collect terms:

$$C \left( \frac{dV}{dt} + \frac{d\hat{v}(t)}{dt} \right) = \underbrace{\left( \frac{D'I}{n} - \frac{V}{R} \right)}_{Dc \text{ terms}} + \underbrace{\left( \frac{D'\hat{i}(t)}{n} - \frac{\hat{v}(t)}{R} - \frac{I\hat{d}(t)}{n} \right)}_{1^{st} \text{ order ac terms (linear)}} - \underbrace{\frac{\hat{d}(t)\hat{i}(t)}{n}}_{2^{nd} \text{ order ac term (nonlinear)}}$$

# Linearization of averaged capacitor equation

---

Dc terms:

$$0 = \left( \frac{D'I}{n} - \frac{V}{R} \right)$$

Second-order terms are small when the small-signal assumption is satisfied. The remaining first-order terms are:

$$C \frac{d\hat{v}(t)}{dt} = \frac{D'\hat{i}(t)}{n} - \frac{\hat{v}(t)}{R} - \frac{I\hat{d}(t)}{n}$$

This is the desired linearized capacitor equation.

# Perturbation of averaged input current equation

---

Original averaged equation:

$$\langle i_g(t) \rangle_{T_s} = d(t) \langle i(t) \rangle_{T_s}$$

Perturb about quiescent operating point:

$$I_g + \hat{i}_g(t) = (D + \hat{d}(t)) (I + \hat{i}(t))$$

Collect terms:

$$\underbrace{I_g}_{\text{Dc term}} + \underbrace{\hat{i}_g(t)}_{1^{\text{st}} \text{ order ac term}} = \underbrace{(DI)}_{\text{Dc term}} + \underbrace{(D\hat{i}(t) + I\hat{d}(t))}_{1^{\text{st}} \text{ order ac terms (linear)}} + \underbrace{\hat{d}(t)\hat{i}(t)}_{2^{\text{nd}} \text{ order ac term (nonlinear)}}$$



# Linearization of averaged input current equation

---

Dc terms:

$$I_g = DI$$

Second-order terms are small when the small-signal assumption is satisfied. The remaining first-order terms are:

$$\hat{i}_g(t) = D\hat{i}(t) + I\hat{d}(t)$$

This is the desired linearized input current equation.

# Summary: dc and small-signal ac converter equations

---

Dc equations:

$$0 = DV_g - D'\frac{V}{n} - DR_{on}I$$

$$0 = \left( \frac{D'I}{n} - \frac{V}{R} \right)$$

$$I_g = DI$$

Small-signal ac equations:

$$L \frac{d\hat{i}(t)}{dt} = D\hat{v}_g(t) - D'\frac{\hat{v}(t)}{n} + \left( V_g + \frac{V}{n} - IR_{on} \right) \hat{d}(t) - DR_{on}\hat{i}(t)$$

$$C \frac{d\hat{v}(t)}{dt} = \frac{D'\hat{i}(t)}{n} - \frac{\hat{v}(t)}{R} - \frac{I\hat{d}(t)}{n}$$

$$\hat{i}_g(t) = D\hat{i}(t) + I\hat{d}(t)$$

Next step: construct equivalent circuit models.

# Small-signal ac equivalent circuit: inductor loop

$$L \frac{d\hat{i}(t)}{dt} = D\hat{v}_g(t) - D' \frac{\hat{v}(t)}{n} + \left( V_g + \frac{V}{n} - IR_{on} \right) \hat{d}(t) - DR_{on} \hat{i}(t)$$

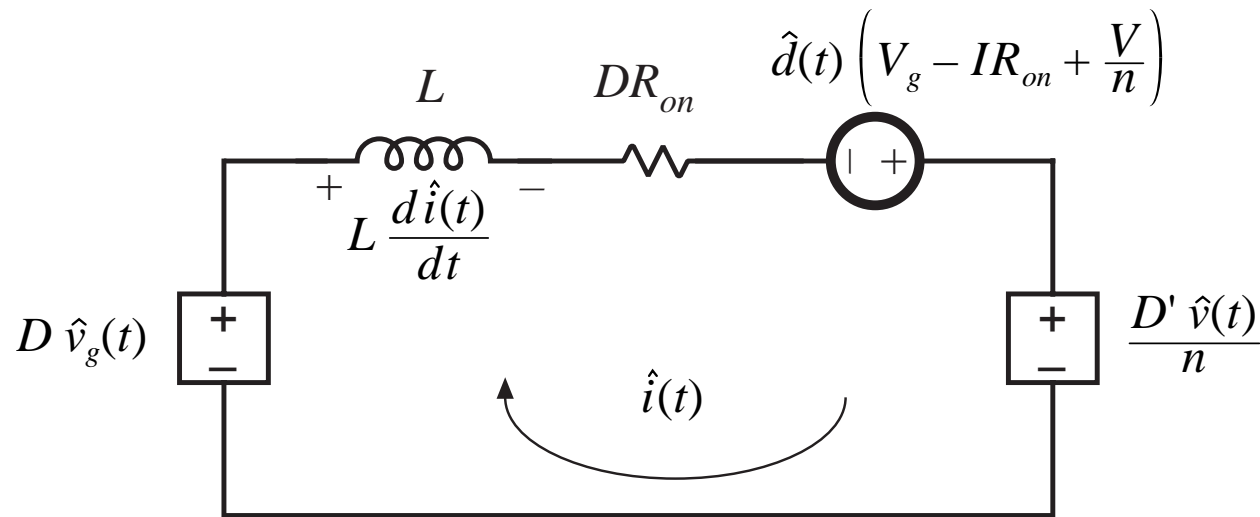

# Small-signal ac equivalent circuit: capacitor node

$$C \frac{d\hat{v}(t)}{dt} = \frac{D'\hat{i}(t)}{n} - \frac{\hat{v}(t)}{R} - \frac{I\hat{d}(t)}{n}$$

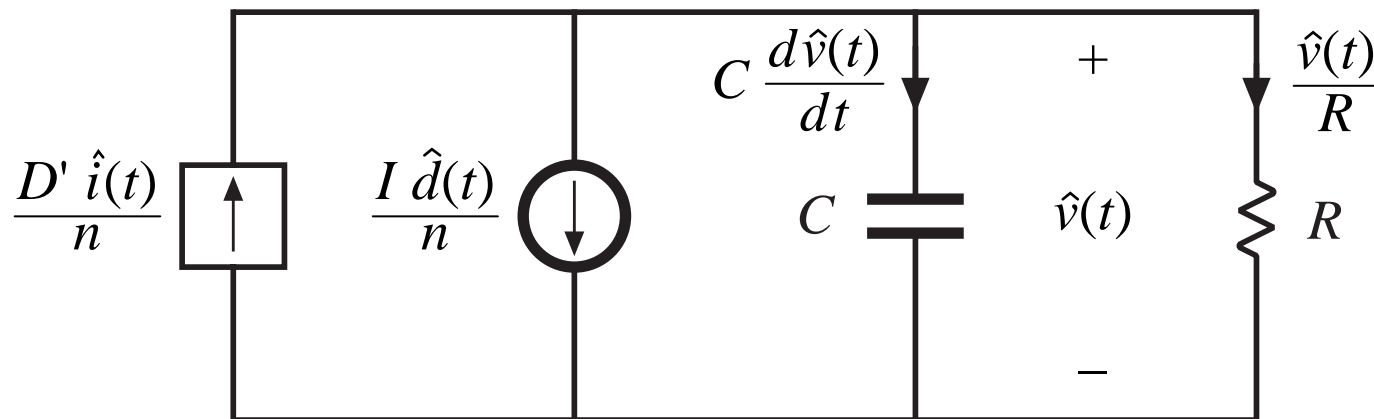

# Small-signal ac equivalent circuit: converter input node

---

$$\hat{i}_g(t) = D\hat{i}(t) + I\hat{d}(t)$$

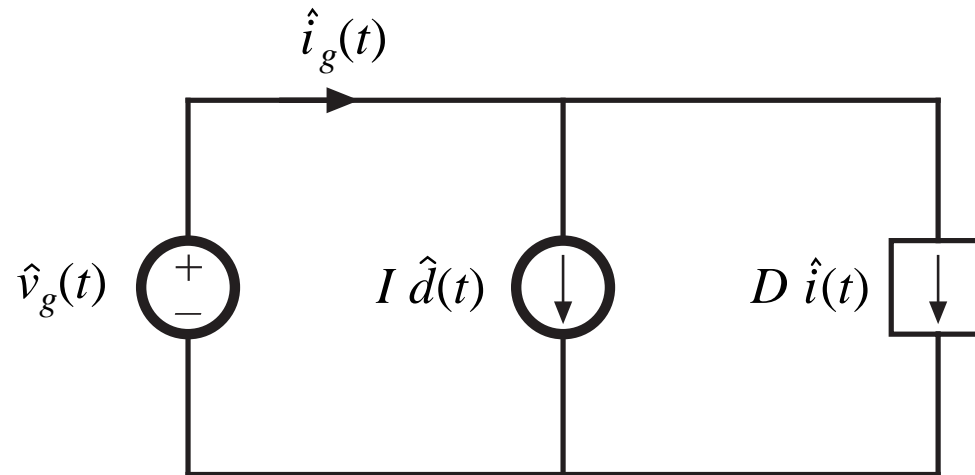

# Small-signal ac model, nonideal flyback converter example

Combine circuits:

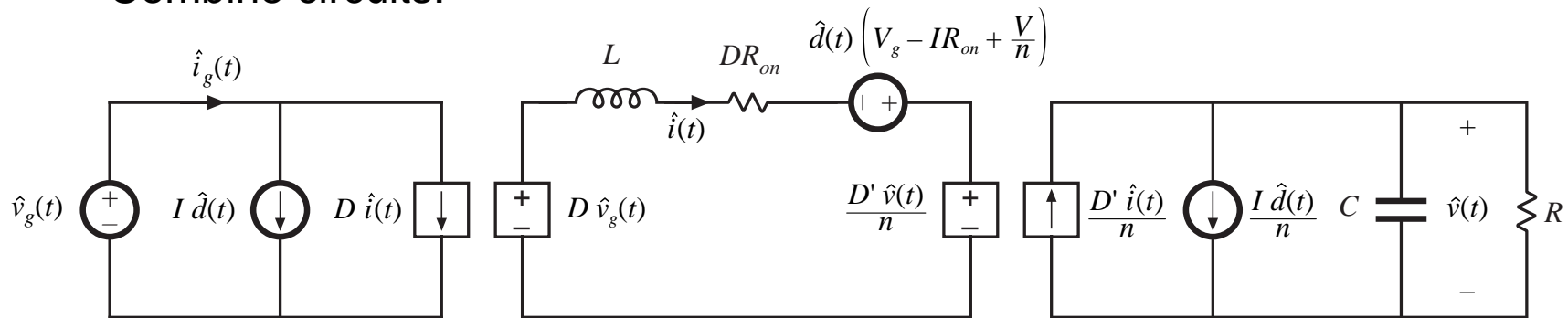

Replace dependent sources with ideal transformers:

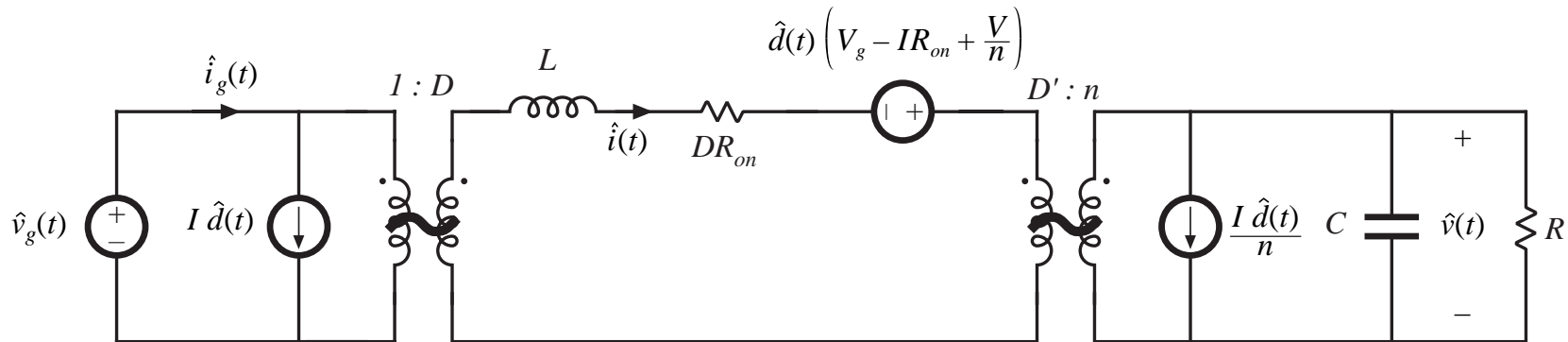

## 7.4. State Space Averaging

---

- A formal method for deriving the small-signal ac equations of a switching converter
- Equivalent to the modeling method of the previous sections
- Uses the state-space matrix description of linear circuits
- Often cited in the literature
- A general approach: if the state equations of the converter can be written for each subinterval, then the small-signal averaged model can always be derived
- Computer programs exist which utilize the state-space averaging method

## 7.4.1. The state equations of a network

---

- A canonical form for writing the differential equations of a system
- If the system is linear, then the derivatives of the *state variables* are expressed as linear combinations of the system independent inputs and state variables themselves
- The physical state variables of a system are usually associated with the storage of energy
- For a typical converter circuit, the physical state variables are the inductor currents and capacitor voltages
- Other typical physical state variables: position and velocity of a motor shaft
- At a given point in time, the values of the state variables depend on the previous history of the system, rather than the present values of the system inputs
- To solve the differential equations of a system, the initial values of the state variables must be specified



## State equations of a linear system, in matrix form

---

A canonical matrix form:  $\mathbf{K} \frac{d\mathbf{x}(t)}{dt} = \mathbf{A} \mathbf{x}(t) + \mathbf{B} \mathbf{u}(t)$

$$\mathbf{y}(t) = \mathbf{C} \mathbf{x}(t) + \mathbf{E} \mathbf{u}(t)$$

State vector  $\mathbf{x}(t)$  contains inductor currents, capacitor voltages, etc.:

$$\mathbf{x}(t) = \begin{bmatrix} x_1(t) \\ x_2(t) \\ \vdots \end{bmatrix}, \quad \frac{d\mathbf{x}(t)}{dt} = \begin{bmatrix} \frac{dx_1(t)}{dt} \\ \frac{dx_2(t)}{dt} \\ \vdots \end{bmatrix}$$

Input vector  $\mathbf{u}(t)$  contains independent sources such as  $v_g(t)$

Output vector  $\mathbf{y}(t)$  contains other dependent quantities to be computed, such as  $i_g(t)$

Matrix  $\mathbf{K}$  contains values of capacitance, inductance, and mutual inductance, so that  $\mathbf{K} d\mathbf{x}/dt$  is a vector containing capacitor currents and inductor winding voltages. These quantities are expressed as linear combinations of the independent inputs and state variables. The matrices  $\mathbf{A}$ ,  $\mathbf{B}$ ,  $\mathbf{C}$ , and  $\mathbf{E}$  contain the constants of proportionality.

# Example

State vector

$$\mathbf{x}(t) = \begin{bmatrix} v_1(t) \\ v_2(t) \\ i(t) \end{bmatrix}$$

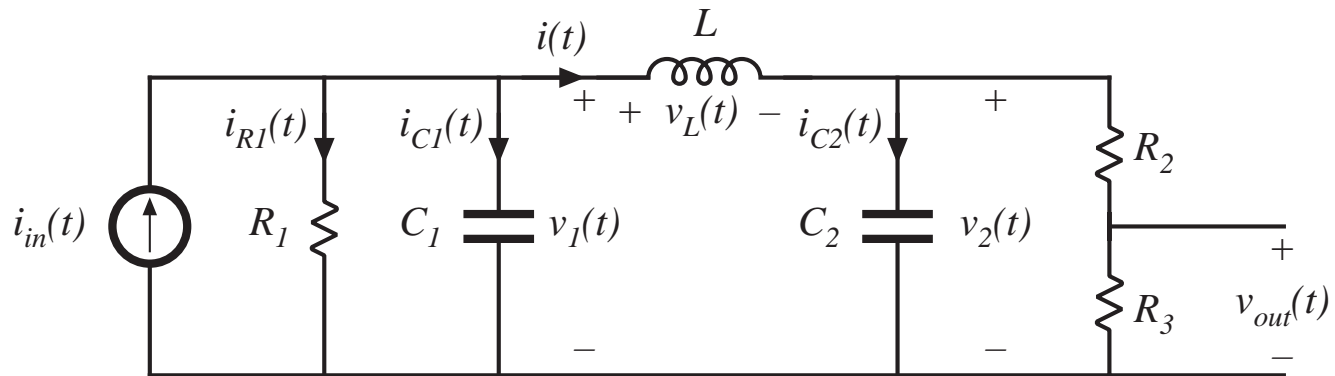

Matrix  $\mathbf{K}$

$$\mathbf{K} = \begin{bmatrix} C_1 & 0 & 0 \\ 0 & C_2 & 0 \\ 0 & 0 & L \end{bmatrix}$$

Input vector

$$\mathbf{u}(t) = \begin{bmatrix} i_{in}(t) \end{bmatrix}$$

Choose output vector as

$$\mathbf{y}(t) = \begin{bmatrix} v_{out}(t) \\ i_{R1}(t) \end{bmatrix}$$

To write the state equations of this circuit, we must express the inductor voltages and capacitor currents as linear combinations of the elements of the  $\mathbf{x}(t)$  and  $\mathbf{u}(t)$  vectors.

# Circuit equations

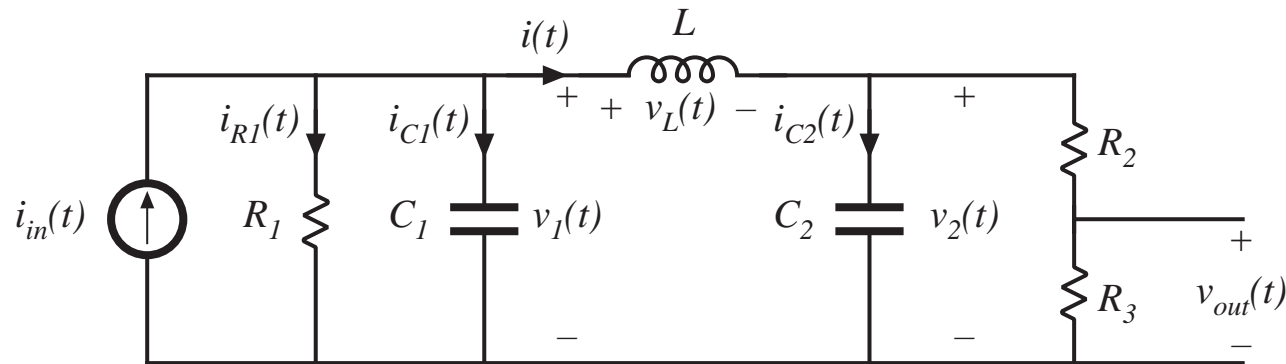

Find  $i_{C1}$  via node equation: 
$$i_{C1}(t) = C_1 \frac{dv_1(t)}{dt} = i_{in}(t) - \frac{v_1(t)}{R} - i(t)$$

Find  $i_{C2}$  via node equation: 
$$i_{C2}(t) = C_2 \frac{dv_2(t)}{dt} = i(t) - \frac{v_2(t)}{R_2 + R_3}$$

Find  $v_L$  via loop equation: 
$$v_L(t) = L \frac{di(t)}{dt} = v_1(t) - v_2(t)$$

# Equations in matrix form

The same equations:

$$i_{c1}(t) = C_1 \frac{dv_1(t)}{dt} = i_{in}(t) - \frac{v_1(t)}{R} - i(t)$$

$$i_{c2}(t) = C_2 \frac{dv_2(t)}{dt} = i(t) - \frac{v_2(t)}{R_2 + R_3}$$

$$v_L(t) = L \frac{di(t)}{dt} = v_1(t) - v_2(t)$$

Express in matrix form:

$$\underbrace{\begin{bmatrix} C_1 & 0 & 0 \\ 0 & C_2 & 0 \\ 0 & 0 & L \end{bmatrix}}_{\mathbf{K}} \underbrace{\begin{bmatrix} \frac{dv_1(t)}{dt} \\ \frac{dv_2(t)}{dt} \\ \frac{di(t)}{dt} \end{bmatrix}}_{\frac{d\mathbf{x}(t)}{dt}} = \underbrace{\begin{bmatrix} -\frac{1}{R_1} & 0 & -1 \\ 0 & -\frac{1}{R_2 + R_3} & 1 \\ 1 & -1 & 0 \end{bmatrix}}_{\mathbf{A}} \underbrace{\begin{bmatrix} v_1(t) \\ v_2(t) \\ i(t) \end{bmatrix}}_{\mathbf{x}(t)} + \underbrace{\begin{bmatrix} 1 \\ 0 \\ 0 \end{bmatrix}}_{\mathbf{B}} \underbrace{\begin{bmatrix} i_{in}(t) \end{bmatrix}}_{\mathbf{u}(t)}$$

# Output (dependent signal) equations

$$\mathbf{y}(t) = \begin{bmatrix} v_{out}(t) \\ i_{R1}(t) \end{bmatrix}$$

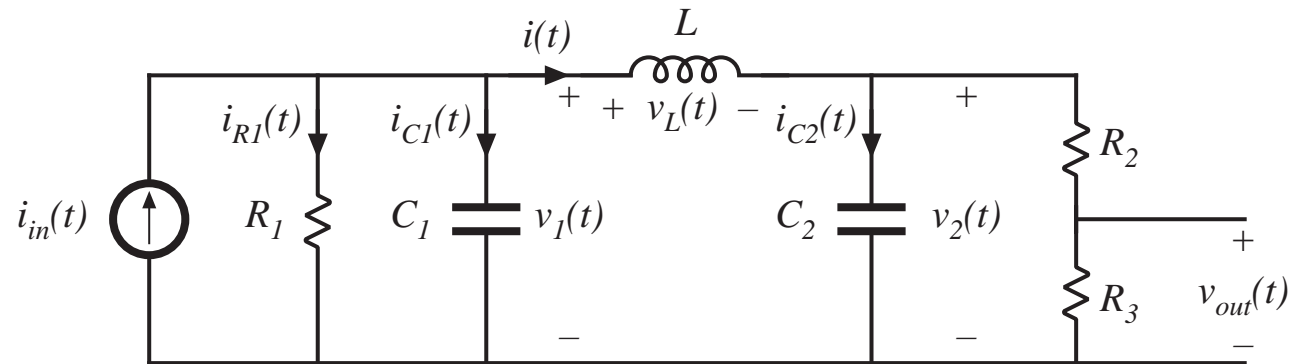

Express elements of the vector  $\mathbf{y}$  as linear combinations of elements of  $\mathbf{x}$  and  $\mathbf{u}$ :

$$v_{out}(t) = v_2(t) \frac{R_3}{R_2 + R_3}$$

$$i_{R1}(t) = \frac{v_1(t)}{R_1}$$

## Express in matrix form

---

The same equations:

$$v_{out}(t) = v_2(t) \frac{R_3}{R_2 + R_3}$$

$$i_{R1}(t) = \frac{v_1(t)}{R_1}$$

Express in matrix form:

$$\underbrace{\begin{bmatrix} v_{out}(t) \\ i_{R1}(t) \end{bmatrix}}_{\mathbf{y}(t)} = \underbrace{\begin{bmatrix} 0 & \frac{R_3}{R_2 + R_3} & 0 \\ \frac{1}{R_1} & 0 & 0 \end{bmatrix}}_{\mathbf{C}} \underbrace{\begin{bmatrix} v_1(t) \\ v_2(t) \\ i(t) \end{bmatrix}}_{\mathbf{x}(t)} + \underbrace{\begin{bmatrix} 0 \\ 0 \end{bmatrix}}_{\mathbf{E}} \underbrace{[i_{in}(t)]}_{\mathbf{u}(t)}$$

## 7.4.2. The basic state-space averaged model

---

*Given:* a PWM converter, operating in continuous conduction mode, with two subintervals during each switching period.

*During subinterval 1,* when the switches are in position 1, the converter reduces to a linear circuit that can be described by the following state equations:

$$\mathbf{K} \frac{d\mathbf{x}(t)}{dt} = \mathbf{A}_1 \mathbf{x}(t) + \mathbf{B}_1 \mathbf{u}(t)$$
$$\mathbf{y}(t) = \mathbf{C}_1 \mathbf{x}(t) + \mathbf{E}_1 \mathbf{u}(t)$$

*During subinterval 2,* when the switches are in position 2, the converter reduces to another linear circuit, that can be described by the following state equations:

$$\mathbf{K} \frac{d\mathbf{x}(t)}{dt} = \mathbf{A}_2 \mathbf{x}(t) + \mathbf{B}_2 \mathbf{u}(t)$$
$$\mathbf{y}(t) = \mathbf{C}_2 \mathbf{x}(t) + \mathbf{E}_2 \mathbf{u}(t)$$

# Equilibrium (dc) state-space averaged model

---

Provided that the natural frequencies of the converter, as well as the frequencies of variations of the converter inputs, are much slower than the switching frequency, then the state-space averaged model that describes the converter in equilibrium is

$$\mathbf{0} = \mathbf{A} \mathbf{X} + \mathbf{B} \mathbf{U}$$
$$\mathbf{Y} = \mathbf{C} \mathbf{X} + \mathbf{E} \mathbf{U}$$

where the averaged matrices are

$$\mathbf{A} = D \mathbf{A}_1 + D' \mathbf{A}_2$$

$$\mathbf{B} = D \mathbf{B}_1 + D' \mathbf{B}_2$$

$$\mathbf{C} = D \mathbf{C}_1 + D' \mathbf{C}_2$$

$$\mathbf{E} = D \mathbf{E}_1 + D' \mathbf{E}_2$$

and the equilibrium dc components are

$\mathbf{X}$  = *equilibrium (dc) state vector*

$\mathbf{U}$  = *equilibrium (dc) input vector*

$\mathbf{Y}$  = *equilibrium (dc) output vector*

$D$  = *equilibrium (dc) duty cycle*



# Solution of equilibrium averaged model

---

Equilibrium state-space averaged model:

$$\mathbf{0} = \mathbf{A} \mathbf{X} + \mathbf{B} \mathbf{U}$$

$$\mathbf{Y} = \mathbf{C} \mathbf{X} + \mathbf{E} \mathbf{U}$$

Solution for  $\mathbf{X}$  and  $\mathbf{Y}$ :

$$\mathbf{X} = -\mathbf{A}^{-1} \mathbf{B} \mathbf{U}$$

$$\mathbf{Y} = \left( -\mathbf{C} \mathbf{A}^{-1} \mathbf{B} + \mathbf{E} \right) \mathbf{U}$$

# Small-signal ac state-space averaged model

---

$$\mathbf{K} \frac{d\hat{\mathbf{x}}(t)}{dt} = \mathbf{A} \hat{\mathbf{x}}(t) + \mathbf{B} \hat{\mathbf{u}}(t) + \left\{ (\mathbf{A}_1 - \mathbf{A}_2) \mathbf{X} + (\mathbf{B}_1 - \mathbf{B}_2) \mathbf{U} \right\} \hat{d}(t)$$
$$\hat{\mathbf{y}}(t) = \mathbf{C} \hat{\mathbf{x}}(t) + \mathbf{E} \hat{\mathbf{u}}(t) + \left\{ (\mathbf{C}_1 - \mathbf{C}_2) \mathbf{X} + (\mathbf{E}_1 - \mathbf{E}_2) \mathbf{U} \right\} \hat{d}(t)$$

where

$\hat{\mathbf{x}}(t)$  = *small – signal (ac) perturbation in state vector*

$\hat{\mathbf{u}}(t)$  = *small – signal (ac) perturbation in input vector*

$\hat{\mathbf{y}}(t)$  = *small – signal (ac) perturbation in output vector*

$\hat{d}(t)$  = *small – signal (ac) perturbation in duty cycle*

So if we can write the converter state equations during subintervals 1 and 2, then we can always find the averaged dc and small-signal ac models

## 7.4.3. Discussion of the state-space averaging result

---

As in Sections 7.1 and 7.2, the low-frequency components of the inductor currents and capacitor voltages are modeled by averaging over an interval of length  $T_s$ . Hence, we define the average of the state vector as:

$$\langle \mathbf{x}(t) \rangle_{T_s} = \frac{1}{T_s} \int_t^{t+T_s} \mathbf{x}(\tau) d\tau$$

The low-frequency components of the input and output vectors are modeled in a similar manner.

By averaging the inductor voltages and capacitor currents, one obtains:

$$\mathbf{K} \frac{d\langle \mathbf{x}(t) \rangle_{T_s}}{dt} = \left( d(t) \mathbf{A}_1 + d'(t) \mathbf{A}_2 \right) \langle \mathbf{x}(t) \rangle_{T_s} + \left( d(t) \mathbf{B}_1 + d'(t) \mathbf{B}_2 \right) \langle \mathbf{u}(t) \rangle_{T_s}$$

## Change in state vector during first subinterval

---

During subinterval 1, we have

$$\begin{aligned}\mathbf{K} \frac{d\mathbf{x}(t)}{dt} &= \mathbf{A}_1 \mathbf{x}(t) + \mathbf{B}_1 \mathbf{u}(t) \\ \mathbf{y}(t) &= \mathbf{C}_1 \mathbf{x}(t) + \mathbf{E}_1 \mathbf{u}(t)\end{aligned}$$

So the elements of  $\mathbf{x}(t)$  change with the slope

$$\frac{d\mathbf{x}(t)}{dt} = \mathbf{K}^{-1} \left( \mathbf{A}_1 \mathbf{x}(t) + \mathbf{B}_1 \mathbf{u}(t) \right)$$

Small ripple assumption: the elements of  $\mathbf{x}(t)$  and  $\mathbf{u}(t)$  do not change significantly during the subinterval. Hence the slopes are essentially constant and are equal to

$$\frac{d\mathbf{x}(t)}{dt} = \mathbf{K}^{-1} \left( \mathbf{A}_1 \langle \mathbf{x}(t) \rangle_{T_s} + \mathbf{B}_1 \langle \mathbf{u}(t) \rangle_{T_s} \right)$$

## Change in state vector during first subinterval

$$\frac{d\mathbf{x}(t)}{dt} = \mathbf{K}^{-1} \left( \mathbf{A}_1 \langle \mathbf{x}(t) \rangle_{T_s} + \mathbf{B}_1 \langle \mathbf{u}(t) \rangle_{T_s} \right)$$

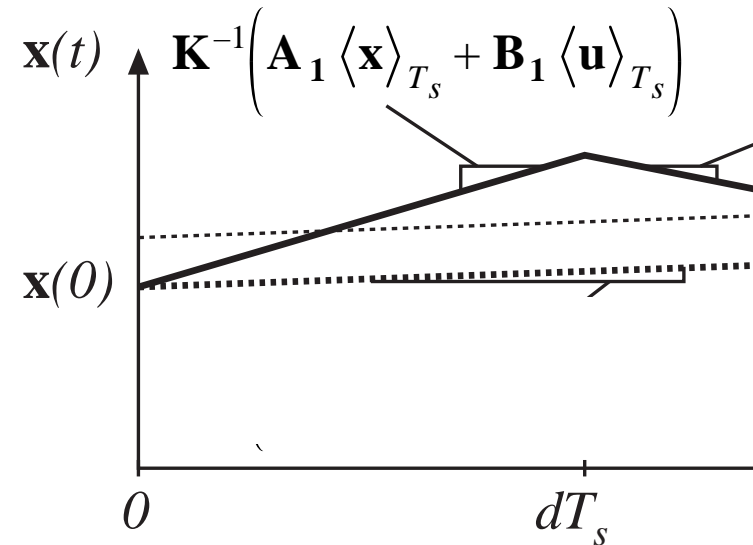

Net change in state vector over first subinterval:

$$\underbrace{\mathbf{x}(dT_s)}_{\text{final value}} = \underbrace{\mathbf{x}(0)}_{\text{initial value}} + \underbrace{(dT_s)}_{\text{interval length}} \underbrace{\mathbf{K}^{-1} \left( \mathbf{A}_1 \langle \mathbf{x}(t) \rangle_{T_s} + \mathbf{B}_1 \langle \mathbf{u}(t) \rangle_{T_s} \right)}_{\text{slope}}$$

## Change in state vector during second subinterval

---

Use similar arguments.

State vector now changes with the essentially constant slope

$$\frac{d\mathbf{x}(t)}{dt} = \mathbf{K}^{-1} \left( \mathbf{A}_2 \langle \mathbf{x}(t) \rangle_{T_s} + \mathbf{B}_2 \langle \mathbf{u}(t) \rangle_{T_s} \right)$$

The value of the state vector at the end of the second subinterval is therefore

$$\underbrace{\mathbf{x}(T_s)}_{\text{final value}} = \underbrace{\mathbf{x}(dT_s)}_{\text{initial value}} + \underbrace{(dT_s)}_{\text{interval length}} \underbrace{\mathbf{K}^{-1} \left( \mathbf{A}_2 \langle \mathbf{x}(t) \rangle_{T_s} + \mathbf{B}_2 \langle \mathbf{u}(t) \rangle_{T_s} \right)}_{\text{slope}}$$

## Net change in state vector over one switching period

---

We have:

$$\mathbf{x}(dT_s) = \mathbf{x}(0) + (dT_s) \mathbf{K}^{-1} \left( \mathbf{A}_1 \langle \mathbf{x}(t) \rangle_{T_s} + \mathbf{B}_1 \langle \mathbf{u}(t) \rangle_{T_s} \right)$$

$$\mathbf{x}(T_s) = \mathbf{x}(dT_s) + (d'T_s) \mathbf{K}^{-1} \left( \mathbf{A}_2 \langle \mathbf{x}(t) \rangle_{T_s} + \mathbf{B}_2 \langle \mathbf{u}(t) \rangle_{T_s} \right)$$

Eliminate  $\mathbf{x}(dT_s)$ , to express  $\mathbf{x}(T_s)$  directly in terms of  $\mathbf{x}(0)$  :

$$\mathbf{x}(T_s) = \mathbf{x}(0) + dT_s \mathbf{K}^{-1} \left( \mathbf{A}_1 \langle \mathbf{x}(t) \rangle_{T_s} + \mathbf{B}_1 \langle \mathbf{u}(t) \rangle_{T_s} \right) + d'T_s \mathbf{K}^{-1} \left( \mathbf{A}_2 \langle \mathbf{x}(t) \rangle_{T_s} + \mathbf{B}_2 \langle \mathbf{u}(t) \rangle_{T_s} \right)$$

Collect terms:

$$\mathbf{x}(T_s) = \mathbf{x}(0) + T_s \mathbf{K}^{-1} \left( d(t) \mathbf{A}_1 + d'(t) \mathbf{A}_2 \right) \langle \mathbf{x}(t) \rangle_{T_s} + T_s \mathbf{K}^{-1} \left( d(t) \mathbf{B}_1 + d'(t) \mathbf{B}_2 \right) \langle \mathbf{u}(t) \rangle_{T_s}$$

## Approximate derivative of state vector

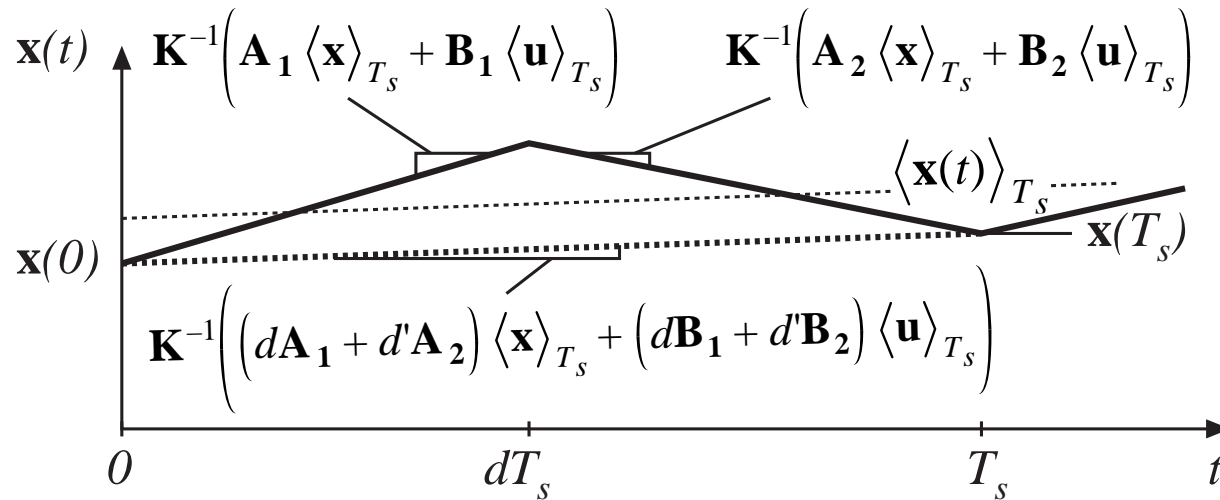

Use Euler approximation:

$$\frac{d\langle \mathbf{x}(t) \rangle_{T_s}}{dt} \approx \frac{\mathbf{x}(T_s) - \mathbf{x}(0)}{T_s}$$

We obtain:

$$\mathbf{K} \frac{d\langle \mathbf{x}(t) \rangle_{T_s}}{dt} = \left( d(t) \mathbf{A}_1 + d'(t) \mathbf{A}_2 \right) \langle \mathbf{x}(t) \rangle_{T_s} + \left( d(t) \mathbf{B}_1 + d'(t) \mathbf{B}_2 \right) \langle \mathbf{u}(t) \rangle_{T_s}$$



# Low-frequency components of output vector

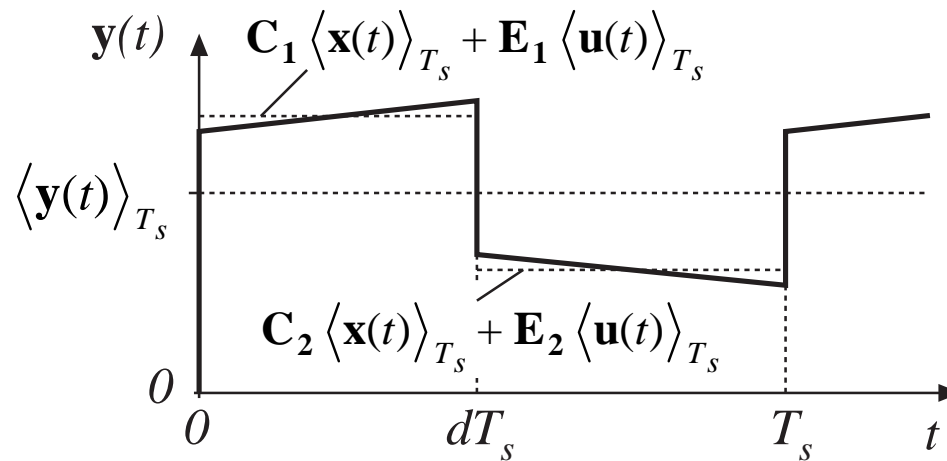

Remove switching harmonics by averaging over one switching period:

$$\langle \mathbf{y}(t) \rangle_{T_s} = d(t) \left( \mathbf{C}_1 \langle \mathbf{x}(t) \rangle_{T_s} + \mathbf{E}_1 \langle \mathbf{u}(t) \rangle_{T_s} \right) + d'(t) \left( \mathbf{C}_2 \langle \mathbf{x}(t) \rangle_{T_s} + \mathbf{E}_2 \langle \mathbf{u}(t) \rangle_{T_s} \right)$$

Collect terms:

$$\langle \mathbf{y}(t) \rangle_{T_s} = \left( d(t) \mathbf{C}_1 + d'(t) \mathbf{C}_2 \right) \langle \mathbf{x}(t) \rangle_{T_s} + \left( d(t) \mathbf{E}_1 + d'(t) \mathbf{E}_2 \right) \langle \mathbf{u}(t) \rangle_{T_s}$$

# Averaged state equations: quiescent operating point

---

The averaged (nonlinear) state equations:

$$\mathbf{K} \frac{d\langle \mathbf{x}(t) \rangle_{T_s}}{dt} = \left( d(t) \mathbf{A}_1 + d'(t) \mathbf{A}_2 \right) \langle \mathbf{x}(t) \rangle_{T_s} + \left( d(t) \mathbf{B}_1 + d'(t) \mathbf{B}_2 \right) \langle \mathbf{u}(t) \rangle_{T_s}$$
$$\langle \mathbf{y}(t) \rangle_{T_s} = \left( d(t) \mathbf{C}_1 + d'(t) \mathbf{C}_2 \right) \langle \mathbf{x}(t) \rangle_{T_s} + \left( d(t) \mathbf{E}_1 + d'(t) \mathbf{E}_2 \right) \langle \mathbf{u}(t) \rangle_{T_s}$$

The converter operates in equilibrium when the derivatives of all elements of  $\langle \mathbf{x}(t) \rangle_{T_s}$  are zero. Hence, the converter quiescent operating point is the solution of

$$\mathbf{0} = \mathbf{A} \mathbf{X} + \mathbf{B} \mathbf{U}$$

$$\mathbf{Y} = \mathbf{C} \mathbf{X} + \mathbf{E} \mathbf{U}$$

where

$\mathbf{A} = D \mathbf{A}_1 + D' \mathbf{A}_2$	and	$\mathbf{X} = \text{equilibrium (dc) state vector}$
$\mathbf{B} = D \mathbf{B}_1 + D' \mathbf{B}_2$		$\mathbf{U} = \text{equilibrium (dc) input vector}$
$\mathbf{C} = D \mathbf{C}_1 + D' \mathbf{C}_2$		$\mathbf{Y} = \text{equilibrium (dc) output vector}$
$\mathbf{E} = D \mathbf{E}_1 + D' \mathbf{E}_2$		$D = \text{equilibrium (dc) duty cycle}$

## Averaged state equations: perturbation and linearization

$$\begin{array}{ll}
 \text{Let } \langle \mathbf{x}(t) \rangle_{T_s} = \mathbf{X} + \hat{\mathbf{x}}(t) & \text{with } \|\mathbf{U}\| \gg \|\hat{\mathbf{u}}(t)\| \\
 \langle \mathbf{u}(t) \rangle_{T_s} = \mathbf{U} + \hat{\mathbf{u}}(t) & D \gg |\hat{d}(t)| \\
 \langle \mathbf{y}(t) \rangle_{T_s} = \mathbf{Y} + \hat{\mathbf{y}}(t) & \|\mathbf{X}\| \gg \|\hat{\mathbf{x}}(t)\| \\
 d(t) = D + \hat{d}(t) \Rightarrow d'(t) = D' - \hat{d}(t) & \|\mathbf{Y}\| \gg \|\hat{\mathbf{y}}(t)\|
 \end{array}$$

Substitute into averaged state equations:

$$\begin{aligned}
 \mathbf{K} \frac{d(\mathbf{X} + \hat{\mathbf{x}}(t))}{dt} &= \left( (D + \hat{d}(t)) \mathbf{A}_1 + (D' - \hat{d}(t)) \mathbf{A}_2 \right) (\mathbf{X} + \hat{\mathbf{x}}(t)) \\
 &+ \left( (D + \hat{d}(t)) \mathbf{B}_1 + (D' - \hat{d}(t)) \mathbf{B}_2 \right) (\mathbf{U} + \hat{\mathbf{u}}(t))
 \end{aligned}$$

$$\begin{aligned}
 (\mathbf{Y} + \hat{\mathbf{y}}(t)) &= \left( (D + \hat{d}(t)) \mathbf{C}_1 + (D' - \hat{d}(t)) \mathbf{C}_2 \right) (\mathbf{X} + \hat{\mathbf{x}}(t)) \\
 &+ \left( (D + \hat{d}(t)) \mathbf{E}_1 + (D' - \hat{d}(t)) \mathbf{E}_2 \right) (\mathbf{U} + \hat{\mathbf{u}}(t))
 \end{aligned}$$

## Averaged state equations: perturbation and linearization

$$\begin{aligned}
 \underbrace{\mathbf{K} \frac{d\hat{\mathbf{x}}(t)}{dt}}_{\text{first-order ac}} &= \underbrace{(\mathbf{A}\mathbf{X} + \mathbf{B}\mathbf{U})}_{\text{dc terms}} + \underbrace{\mathbf{A}\hat{\mathbf{x}}(t) + \mathbf{B}\hat{\mathbf{u}}(t) + \left\{ (\mathbf{A}_1 - \mathbf{A}_2)\mathbf{X} + (\mathbf{B}_1 - \mathbf{B}_2)\mathbf{U} \right\} \hat{d}(t)}_{\text{first-order ac terms}} \\
 &+ \underbrace{(\mathbf{A}_1 - \mathbf{A}_2)\hat{\mathbf{x}}(t)\hat{d}(t) + (\mathbf{B}_1 - \mathbf{B}_2)\hat{\mathbf{u}}(t)\hat{d}(t)}_{\text{second-order nonlinear terms}}
 \end{aligned}$$
  

$$\begin{aligned}
 \underbrace{(\mathbf{Y} + \hat{\mathbf{y}}(t))}_{\text{dc} + 1\text{st order ac}} &= \underbrace{(\mathbf{C}\mathbf{X} + \mathbf{E}\mathbf{U})}_{\text{dc terms}} + \underbrace{\mathbf{C}\hat{\mathbf{x}}(t) + \mathbf{E}\hat{\mathbf{u}}(t) + \left\{ (\mathbf{C}_1 - \mathbf{C}_2)\mathbf{X} + (\mathbf{E}_1 - \mathbf{E}_2)\mathbf{U} \right\} \hat{d}(t)}_{\text{first-order ac terms}} \\
 &+ \underbrace{(\mathbf{C}_1 - \mathbf{C}_2)\hat{\mathbf{x}}(t)\hat{d}(t) + (\mathbf{E}_1 - \mathbf{E}_2)\hat{\mathbf{u}}(t)\hat{d}(t)}_{\text{second-order nonlinear terms}}
 \end{aligned}$$

# Linearized small-signal state equations

---

Dc terms drop out of equations. Second-order (nonlinear) terms are small when the small-signal assumption is satisfied. We are left with:

$$\mathbf{K} \frac{d\hat{\mathbf{x}}(t)}{dt} = \mathbf{A} \hat{\mathbf{x}}(t) + \mathbf{B} \hat{\mathbf{u}}(t) + \left\{ (\mathbf{A}_1 - \mathbf{A}_2) \mathbf{X} + (\mathbf{B}_1 - \mathbf{B}_2) \mathbf{U} \right\} \hat{d}(t)$$
$$\hat{\mathbf{y}}(t) = \mathbf{C} \hat{\mathbf{x}}(t) + \mathbf{E} \hat{\mathbf{u}}(t) + \left\{ (\mathbf{C}_1 - \mathbf{C}_2) \mathbf{X} + (\mathbf{E}_1 - \mathbf{E}_2) \mathbf{U} \right\} \hat{d}(t)$$

This is the desired result.

## 7.4.4. Example: State-space averaging of a nonideal buck-boost converter

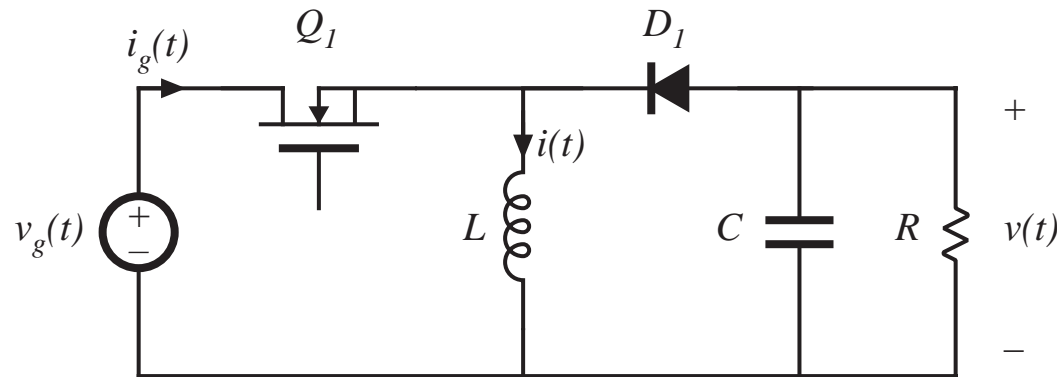

Model nonidealities:

- MOSFET on-resistance  $R_{on}$
- Diode forward voltage drop  $V_D$

state vector

$$\mathbf{x}(t) = \begin{bmatrix} i(t) \\ v(t) \end{bmatrix}$$

input vector

$$\mathbf{u}(t) = \begin{bmatrix} v_g(t) \\ V_D \end{bmatrix}$$

output vector

$$\mathbf{y}(t) = \begin{bmatrix} i_g(t) \end{bmatrix}$$

# Subinterval 1

$$L \frac{di(t)}{dt} = v_g(t) - i(t) R_{on}$$

$$C \frac{dv(t)}{dt} = -\frac{v(t)}{R}$$

$$i_g(t) = i(t)$$

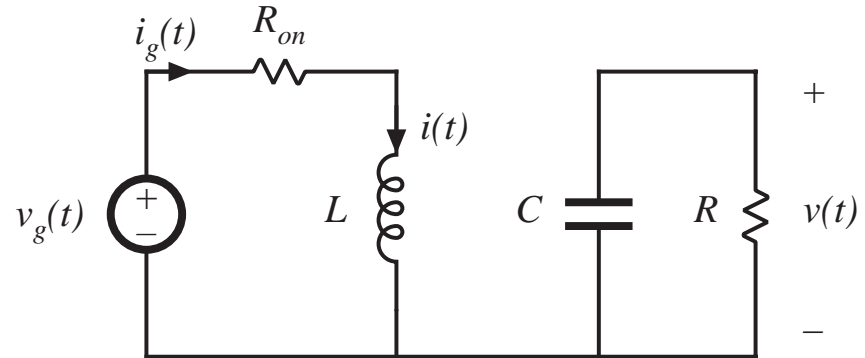

$$\underbrace{\begin{bmatrix} L & 0 \\ 0 & C \end{bmatrix}}_{\mathbf{K}} \underbrace{\frac{d}{dt} \begin{bmatrix} i(t) \\ v(t) \end{bmatrix}}_{\frac{d\mathbf{x}(t)}{dt}} = \underbrace{\begin{bmatrix} -R_{on} & 0 \\ 0 & -\frac{1}{R} \end{bmatrix}}_{\mathbf{A}_1} \underbrace{\begin{bmatrix} i(t) \\ v(t) \end{bmatrix}}_{\mathbf{x}(t)} + \underbrace{\begin{bmatrix} 1 & 0 \\ 0 & 0 \end{bmatrix}}_{\mathbf{B}_1} \underbrace{\begin{bmatrix} v_g(t) \\ V_D \end{bmatrix}}_{\mathbf{u}(t)}$$

$$\mathbf{K} \quad \frac{d\mathbf{x}(t)}{dt} \quad \mathbf{A}_1 \quad \mathbf{x}(t) \quad \mathbf{B}_1 \quad \mathbf{u}(t)$$

$$\underbrace{\begin{bmatrix} i_g(t) \end{bmatrix}}_{\mathbf{y}(t)} = \underbrace{\begin{bmatrix} 1 & 0 \end{bmatrix}}_{\mathbf{C}_1} \underbrace{\begin{bmatrix} i(t) \\ v(t) \end{bmatrix}}_{\mathbf{x}(t)} + \underbrace{\begin{bmatrix} 0 & 0 \end{bmatrix}}_{\mathbf{E}_1} \underbrace{\begin{bmatrix} v_g(t) \\ V_D \end{bmatrix}}_{\mathbf{u}(t)}$$

## Subinterval 2

$$\begin{aligned}
 L \frac{di(t)}{dt} &= v(t) - V_D \\
 C \frac{dv(t)}{dt} &= -\frac{v(t)}{R} - i(t) \\
 i_g(t) &= 0
 \end{aligned}$$

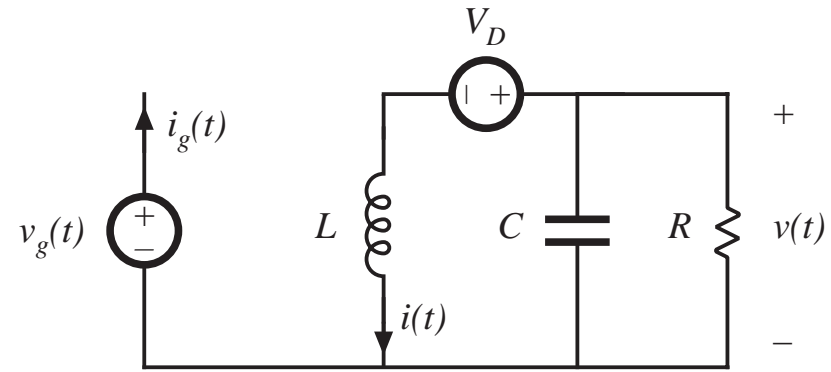

$$\underbrace{\begin{bmatrix} L & 0 \\ 0 & C \end{bmatrix}}_{\mathbf{K}} \underbrace{\frac{d}{dt} \begin{bmatrix} i(t) \\ v(t) \end{bmatrix}}_{\frac{d\mathbf{x}(t)}{dt}} = \underbrace{\begin{bmatrix} 0 & 1 \\ -1 & -\frac{1}{R} \end{bmatrix}}_{\mathbf{A}_2} \underbrace{\begin{bmatrix} i(t) \\ v(t) \end{bmatrix}}_{\mathbf{x}(t)} + \underbrace{\begin{bmatrix} 0 & -1 \\ 0 & 0 \end{bmatrix}}_{\mathbf{B}_2} \underbrace{\begin{bmatrix} v_g(t) \\ V_D \end{bmatrix}}_{\mathbf{u}(t)}$$

$$\mathbf{K} \quad \frac{d\mathbf{x}(t)}{dt} \quad \mathbf{A}_2 \quad \mathbf{x}(t) \quad \mathbf{B}_2 \quad \mathbf{u}(t)$$

$$\underbrace{\begin{bmatrix} i_g(t) \end{bmatrix}}_{\mathbf{y}(t)} = \underbrace{\begin{bmatrix} 0 & 0 \end{bmatrix}}_{\mathbf{C}_2} \underbrace{\begin{bmatrix} i(t) \\ v(t) \end{bmatrix}}_{\mathbf{x}(t)} + \underbrace{\begin{bmatrix} 0 & 0 \end{bmatrix}}_{\mathbf{E}_2} \underbrace{\begin{bmatrix} v_g(t) \\ V_D \end{bmatrix}}_{\mathbf{u}(t)}$$

$$\mathbf{y}(t) \quad \mathbf{C}_2 \quad \mathbf{x}(t) \quad \mathbf{E}_2 \quad \mathbf{u}(t)$$



## Evaluate averaged matrices

---

$$\mathbf{A} = D\mathbf{A}_1 + D'\mathbf{A}_2 = D \begin{bmatrix} -R_{on} & 0 \\ 0 & -\frac{1}{R} \end{bmatrix} + D' \begin{bmatrix} 0 & 1 \\ -1 & -\frac{1}{R} \end{bmatrix} = \begin{bmatrix} -DR_{on} & D' \\ -D' & -\frac{1}{R} \end{bmatrix}$$

In a similar manner,

$$\mathbf{B} = D\mathbf{B}_1 + D'\mathbf{B}_2 = \begin{bmatrix} D & -D' \\ 0 & 0 \end{bmatrix}$$

$$\mathbf{C} = D\mathbf{C}_1 + D'\mathbf{C}_2 = \begin{bmatrix} D & 0 \end{bmatrix}$$

$$\mathbf{E} = D\mathbf{E}_1 + D'\mathbf{E}_2 = \begin{bmatrix} 0 & 0 \end{bmatrix}$$

## DC state equations

---

$$\begin{aligned}
 \mathbf{0} &= \mathbf{A} \mathbf{X} + \mathbf{B} \mathbf{U} \\
 \mathbf{Y} &= \mathbf{C} \mathbf{X} + \mathbf{E} \mathbf{U}
 \end{aligned}
 \quad \text{or,} \quad
 \begin{aligned}
 \begin{bmatrix} 0 \\ 0 \end{bmatrix} &= \begin{bmatrix} -DR_{on} & D' \\ -D' & -\frac{1}{R} \end{bmatrix} \begin{bmatrix} I \\ V \end{bmatrix} + \begin{bmatrix} D & -D' \\ 0 & 0 \end{bmatrix} \begin{bmatrix} V_g \\ V_D \end{bmatrix} \\
 I_g &= \begin{bmatrix} D & 0 \end{bmatrix} \begin{bmatrix} I \\ V \end{bmatrix} + \begin{bmatrix} 0 & 0 \end{bmatrix} \begin{bmatrix} V_g \\ V_D \end{bmatrix}
 \end{aligned}$$

---

DC solution:

$$\begin{aligned}
 \begin{bmatrix} I \\ V \end{bmatrix} &= \left( \frac{1}{1 + \frac{D}{D'^2} \frac{R_{on}}{R}} \right) \begin{bmatrix} \frac{D}{D'^2 R} & \frac{1}{D' R} \\ -\frac{D}{D'} & 1 \end{bmatrix} \begin{bmatrix} V_g \\ V_D \end{bmatrix} \\
 I_g &= \left( \frac{1}{1 + \frac{D}{D'^2} \frac{R_{on}}{R}} \right) \begin{bmatrix} D^2 & D \\ D'^2 R & D'R \end{bmatrix} \begin{bmatrix} V_g \\ V_D \end{bmatrix}
 \end{aligned}$$

# Steady-state equivalent circuit

DC state equations:

$$\begin{bmatrix} 0 \\ 0 \end{bmatrix} = \begin{bmatrix} -DR_{on} & D' \\ -D' & -\frac{1}{R} \end{bmatrix} \begin{bmatrix} I \\ V \end{bmatrix} + \begin{bmatrix} D & -D' \\ 0 & 0 \end{bmatrix} \begin{bmatrix} V_g \\ V_D \end{bmatrix}$$

$$\begin{bmatrix} I_g \\ \end{bmatrix} = \begin{bmatrix} D & 0 \\ \end{bmatrix} \begin{bmatrix} I \\ V \end{bmatrix} + \begin{bmatrix} 0 & 0 \\ \end{bmatrix} \begin{bmatrix} V_g \\ V_D \end{bmatrix}$$

Corresponding equivalent circuit:

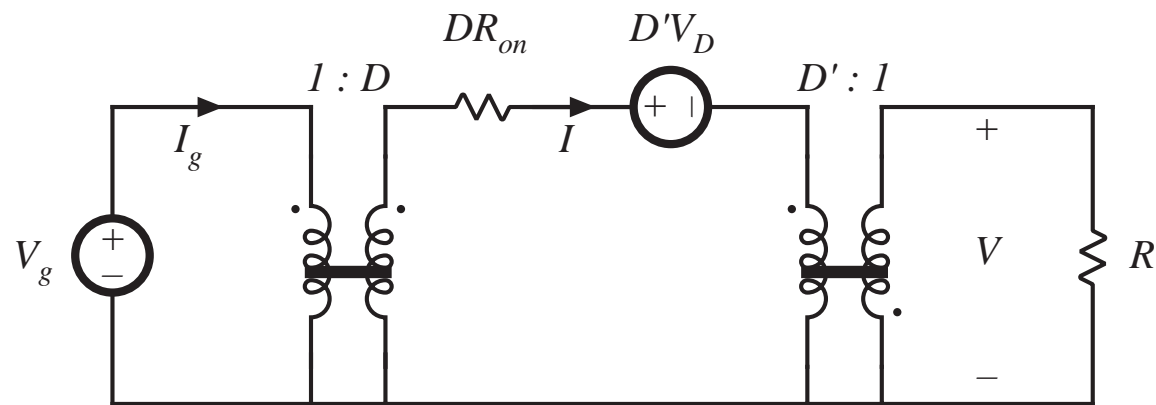

# Small-signal ac model

Evaluate matrices in small-signal model:

$$(\mathbf{A}_1 - \mathbf{A}_2) \mathbf{X} + (\mathbf{B}_1 - \mathbf{B}_2) \mathbf{U} = \begin{bmatrix} -V \\ I \end{bmatrix} + \begin{bmatrix} V_g - IR_{on} + V_D \\ 0 \end{bmatrix} = \begin{bmatrix} V_g - V - IR_{on} + V_D \\ I \end{bmatrix}$$

$$(\mathbf{C}_1 - \mathbf{C}_2) \mathbf{X} + (\mathbf{E}_1 - \mathbf{E}_2) \mathbf{U} = [I]$$

Small-signal ac state equations:

$$\begin{bmatrix} L & 0 \\ 0 & C \end{bmatrix} \frac{d}{dt} \begin{bmatrix} \hat{i}(t) \\ \hat{v}(t) \end{bmatrix} = \begin{bmatrix} -DR_{on} & D' \\ -D' & -\frac{1}{R} \end{bmatrix} \begin{bmatrix} \hat{i}(t) \\ \hat{v}(t) \end{bmatrix} + \begin{bmatrix} D & -D' \\ 0 & 0 \end{bmatrix} \begin{bmatrix} \hat{v}_g(t) \\ \hat{v}_D(t) \end{bmatrix} + \begin{bmatrix} V_g - V - IR_{on} + V_D \\ I \end{bmatrix} \hat{d}(t)$$

$$\begin{bmatrix} \hat{i}_g(t) \end{bmatrix} = \begin{bmatrix} D & 0 \end{bmatrix} \begin{bmatrix} \hat{i}(t) \\ \hat{v}(t) \end{bmatrix} + \begin{bmatrix} 0 & 0 \\ 0 & 0 \end{bmatrix} \begin{bmatrix} \hat{v}_g(t) \\ \hat{v}_D(t) \end{bmatrix} + \begin{bmatrix} 0 \\ I \end{bmatrix} \hat{d}(t)$$

# Construction of ac equivalent circuit

Small-signal ac equations, in scalar form:

$$L \frac{d\hat{i}(t)}{dt} = D' \hat{v}(t) - DR_{on} \hat{i}(t) + D \hat{v}_g(t) + (V_g - V - IR_{on} + V_D) \hat{d}(t)$$

$$C \frac{d\hat{v}(t)}{dt} = -D' \hat{i}(t) - \frac{\hat{v}(t)}{R} + I \hat{d}(t)$$

$$\hat{i}_g(t) = D \hat{i}(t) + I \hat{d}(t)$$

Corresponding equivalent circuits:

*inductor equation*

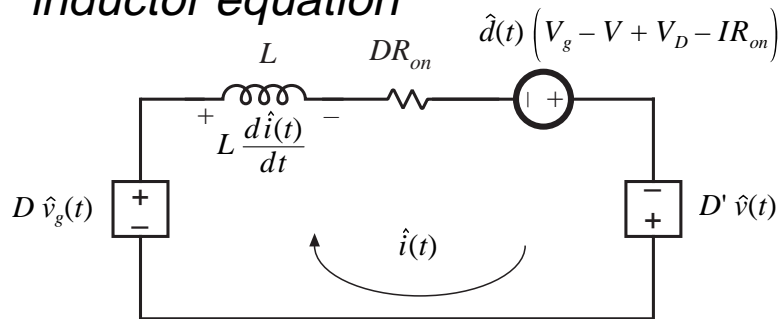

*input eqn*

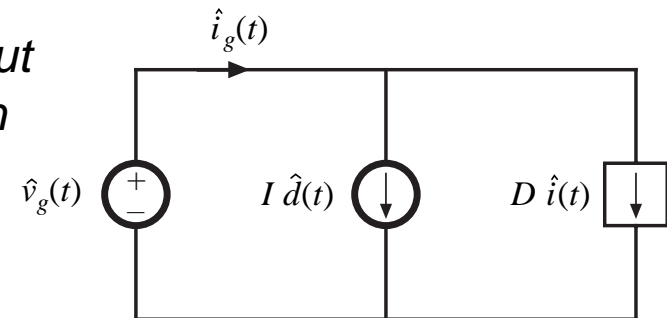

*capacitor eqn*

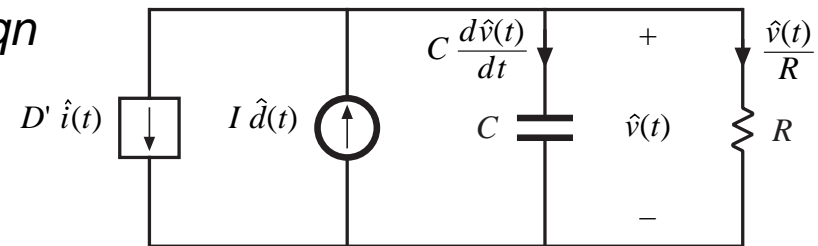

# Complete small-signal ac equivalent circuit

Combine individual circuits to obtain

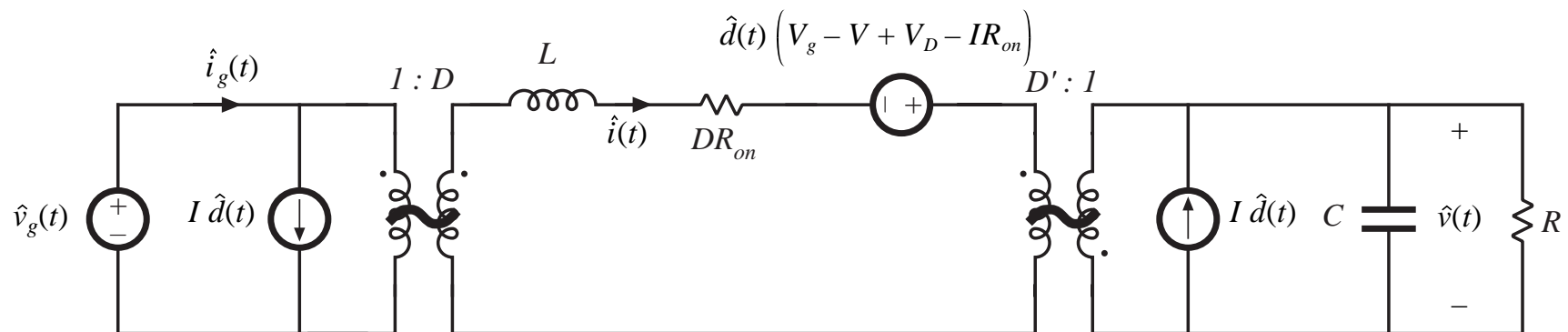

## 7.5. Circuit Averaging and Averaged Switch Modeling

---

- Historically, circuit averaging was the first method known for modeling the small-signal ac behavior of CCM PWM converters
- It was originally thought to be difficult to apply in some cases
- There has been renewed interest in circuit averaging and its corrolary, averaged switch modeling, in the last decade
- Can be applied to a wide variety of converters
  - We will use it to model DCM, CPM, and resonant converters
  - Also useful for incorporating switching loss into ac model of CCM converters
  - Applicable to 3 $\phi$  PWM inverters and rectifiers
  - Can be applied to phase-controlled rectifiers
- Rather than averaging and linearizing the converter state equations, the averaging and linearization operations are performed directly on the converter circuit

# Separate switch network from remainder of converter

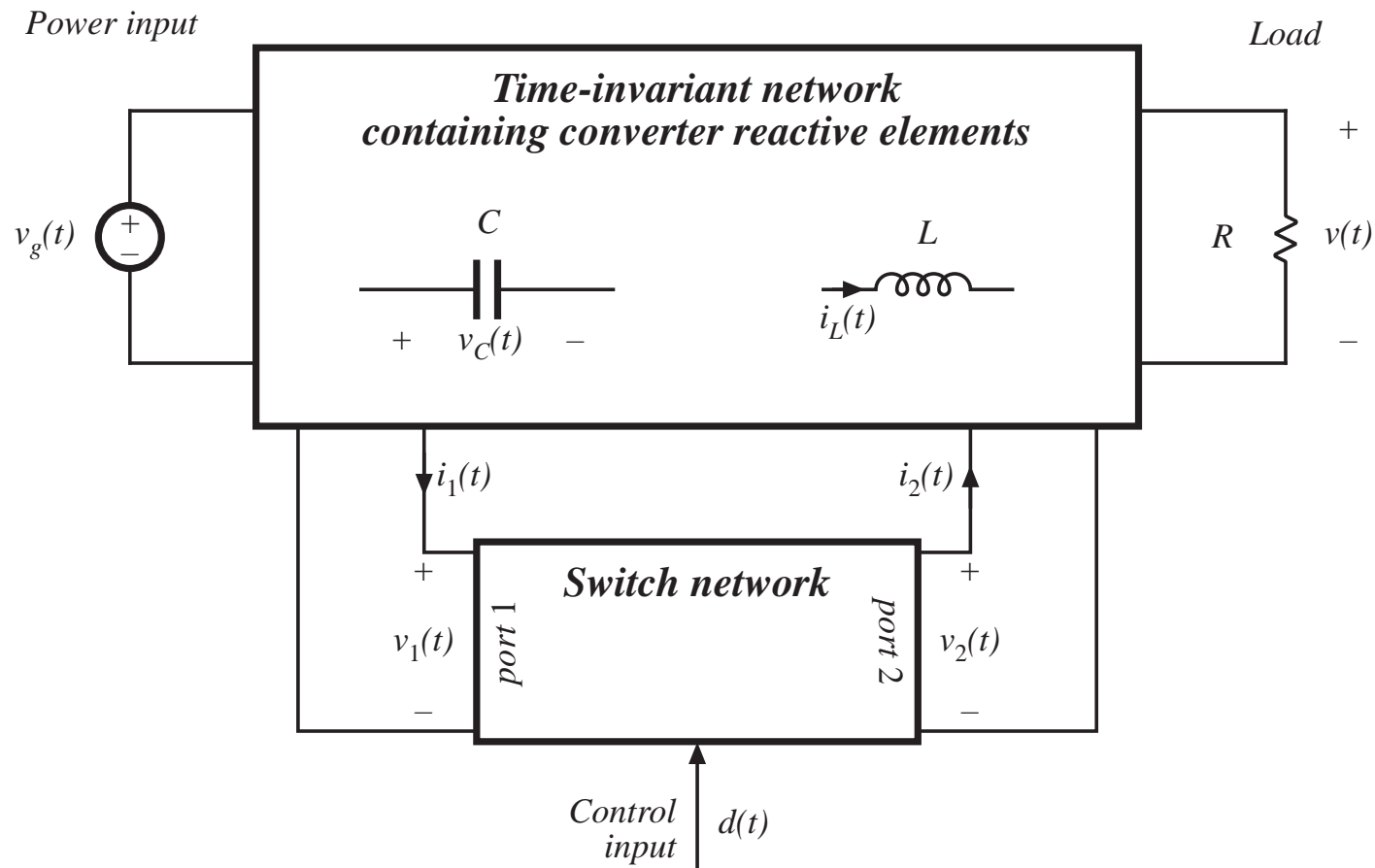



# Boost converter example

*Ideal boost converter example*

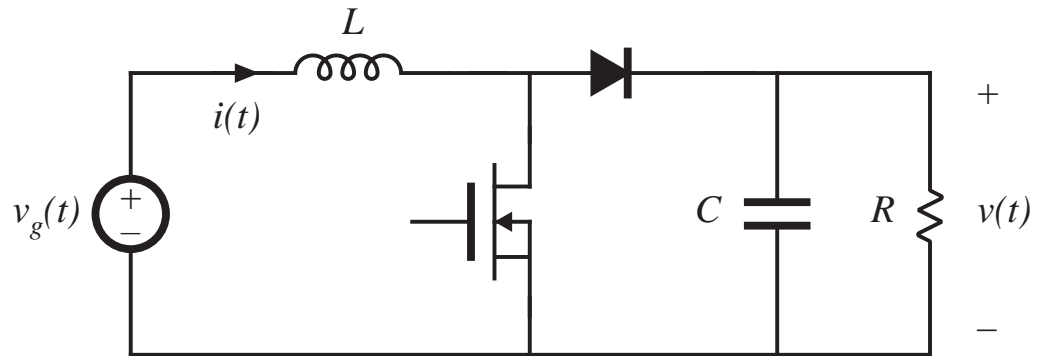

*Two ways to define the switch network*

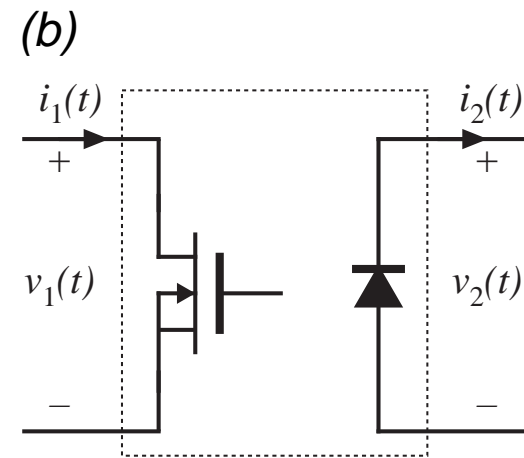
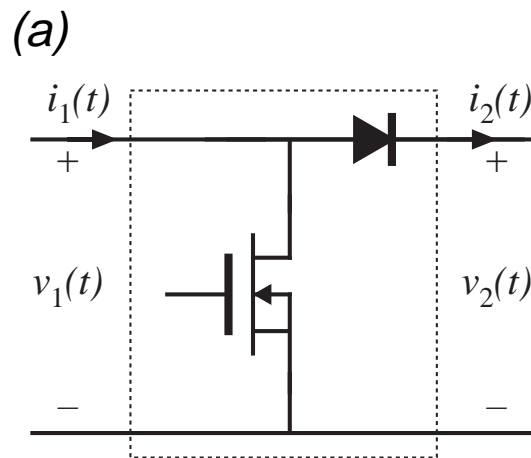

# Discussion

---

- The number of ports in the switch network is less than or equal to the number of SPST switches
- Simple dc-dc case, in which converter contains two SPST switches: switch network contains two ports
  - The switch network terminal waveforms are then the port voltages and currents:  $v_1(t)$ ,  $i_1(t)$ ,  $v_2(t)$ , and  $i_2(t)$ .
  - Two of these waveforms can be taken as independent inputs to the switch network; the remaining two waveforms are then viewed as dependent outputs of the switch network.
- Definition of the switch network terminal quantities is not unique. Different definitions lead equivalent results having different forms

# Boost converter example

Let's use definition (a):

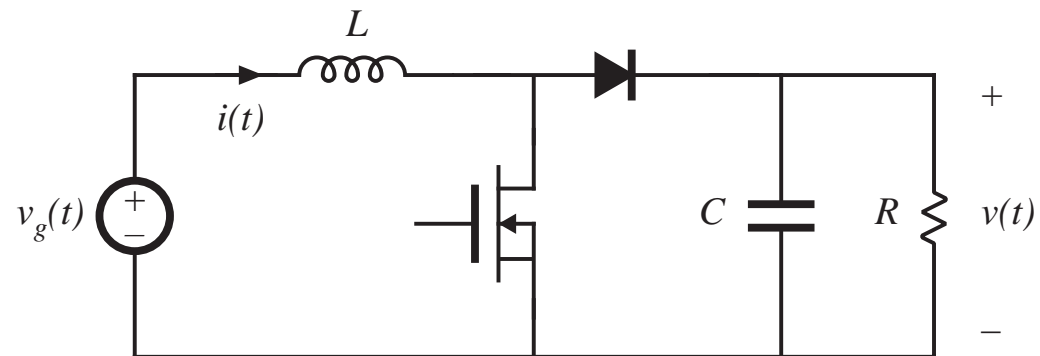
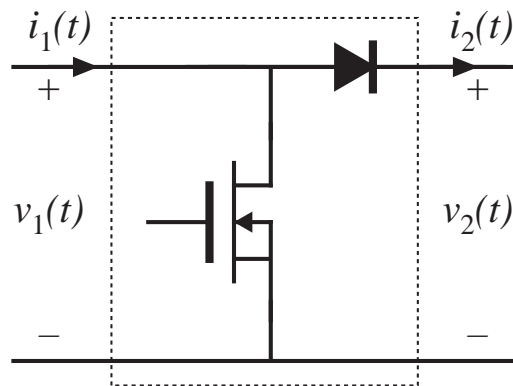

Since  $i_1(t)$  and  $v_2(t)$  coincide with the converter inductor current and output voltage, it is convenient to define these waveforms as the independent inputs to the switch network. The switch network dependent outputs are then  $v_1(t)$  and  $i_2(t)$ .

# Obtaining a time-invariant network: Modeling the terminal behavior of the switch network

Replace the switch network with dependent sources, which correctly represent the dependent output waveforms of the switch network

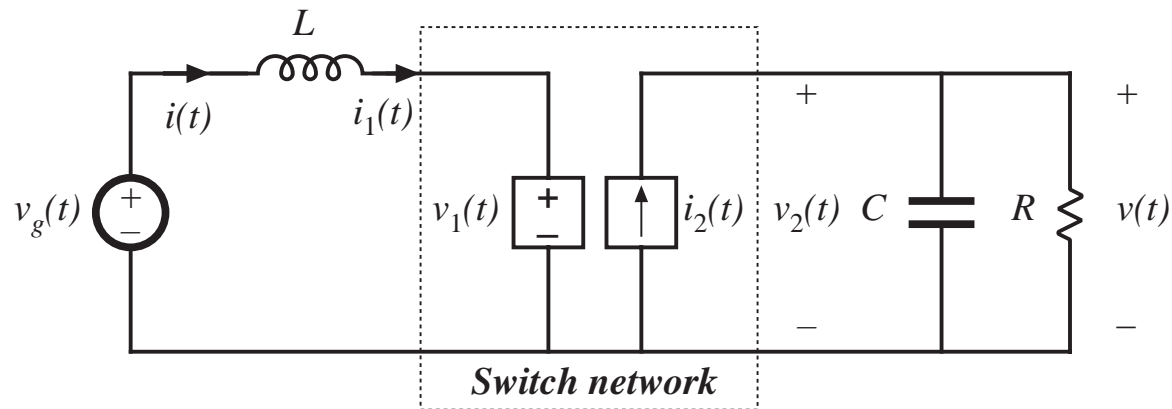

*Boost converter example*

# Definition of dependent generator waveforms

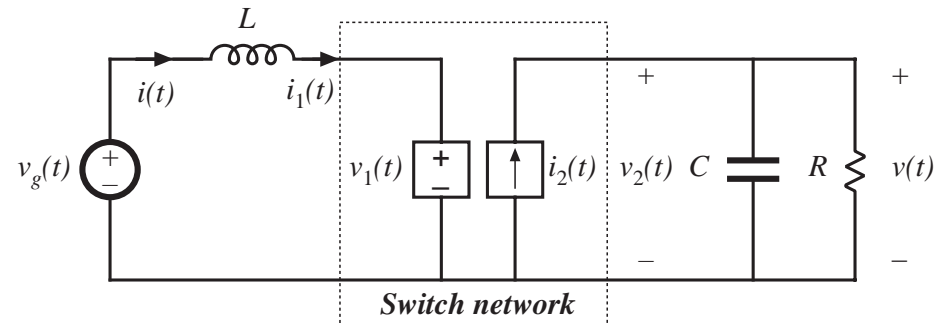
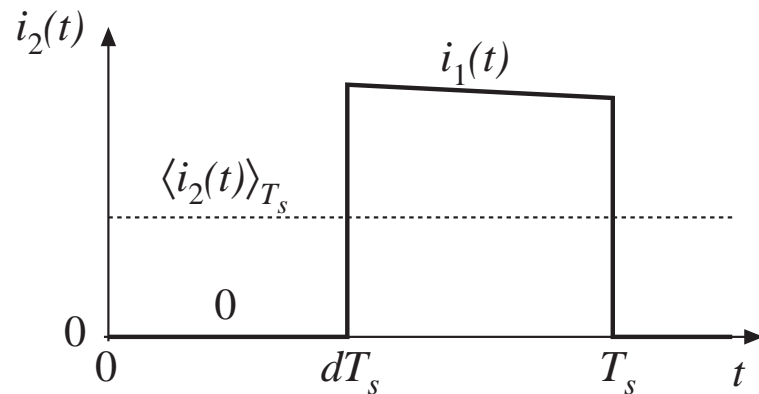
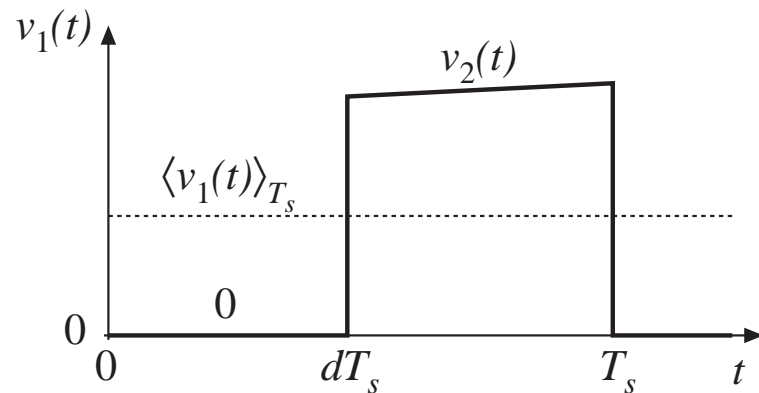

The waveforms of the dependent generators are defined to be identical to the actual terminal waveforms of the switch network.

The circuit is therefore electrical identical to the original converter.

So far, no approximations have been made.

# The circuit averaging step

Now average all waveforms over one switching period:

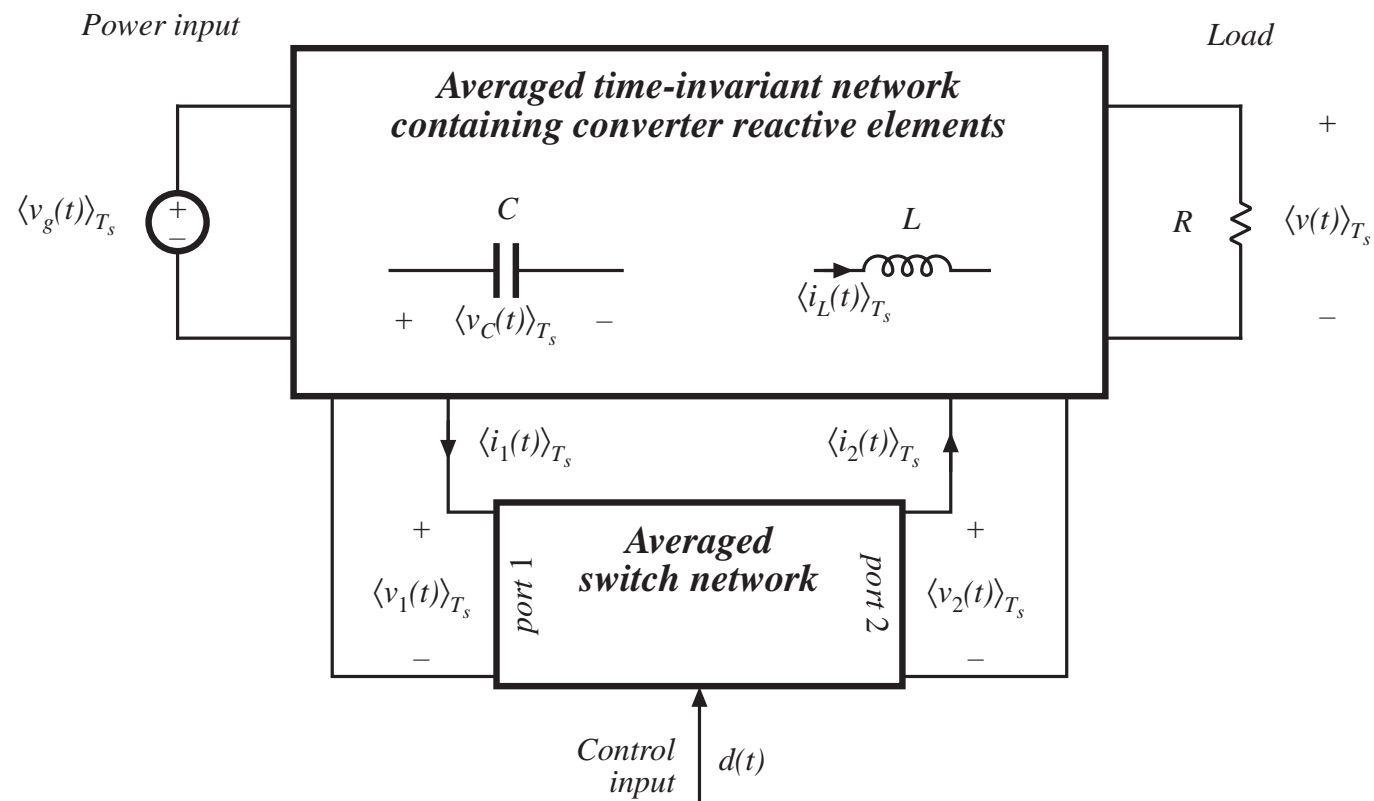

# The averaging step

---

The basic assumption is made that the natural time constants of the converter are much longer than the switching period, so that the converter contains low-pass filtering of the switching harmonics. One may average the waveforms over an interval that is short compared to the system natural time constants, without significantly altering the system response. In particular, averaging over the switching period  $T_s$  removes the switching harmonics, while preserving the low-frequency components of the waveforms.

In practice, the only work needed for this step is to average the switch dependent waveforms.

# Averaging step: boost converter example

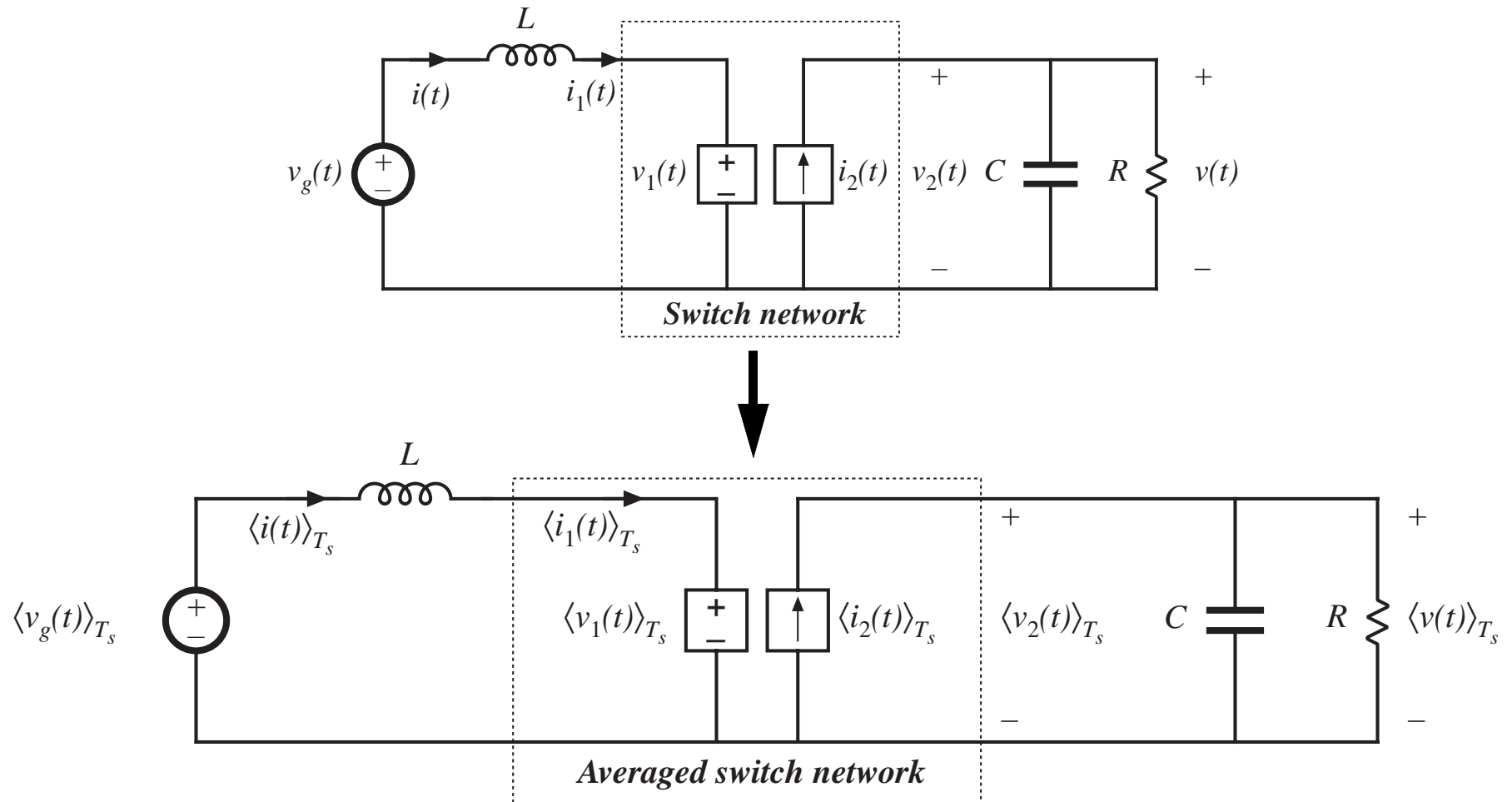



# Compute average values of dependent sources

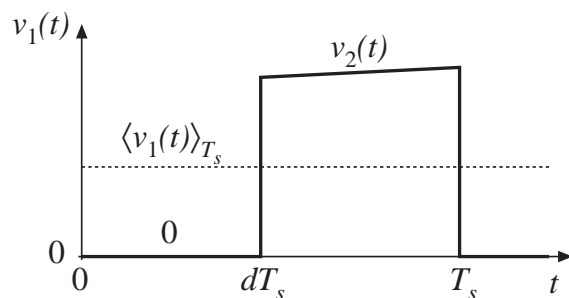

Average the waveforms of the dependent sources:

$$\langle v_1(t) \rangle_{T_s} = d'(t) \langle v_2(t) \rangle_{T_s}$$

$$\langle i_2(t) \rangle_{T_s} = d'(t) \langle i_1(t) \rangle_{T_s}$$

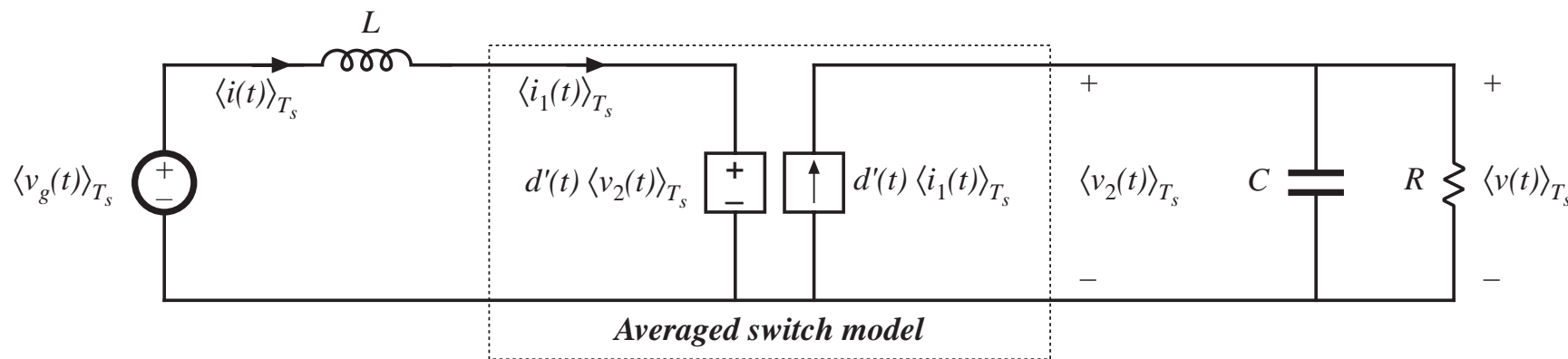
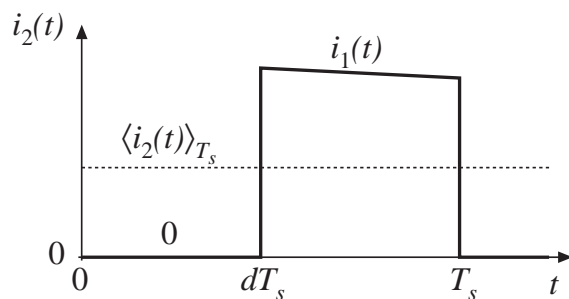

# Perturb and linearize

As usual, let:

$$\langle v_g(t) \rangle_{T_s} = V_g + \hat{v}_g(t)$$

$$d(t) = D + \hat{d}(t) \Rightarrow d'(t) = D' - \hat{d}(t)$$

$$\langle i(t) \rangle_{T_s} = \langle i_1(t) \rangle_{T_s} = I + \hat{i}(t)$$

$$\langle v(t) \rangle_{T_s} = \langle v_2(t) \rangle_{T_s} = V + \hat{v}(t)$$

$$\langle v_1(t) \rangle_{T_s} = V_1 + \hat{v}_1(t)$$

$$\langle i_2(t) \rangle_{T_s} = I_2 + \hat{i}_2(t)$$

The circuit becomes:

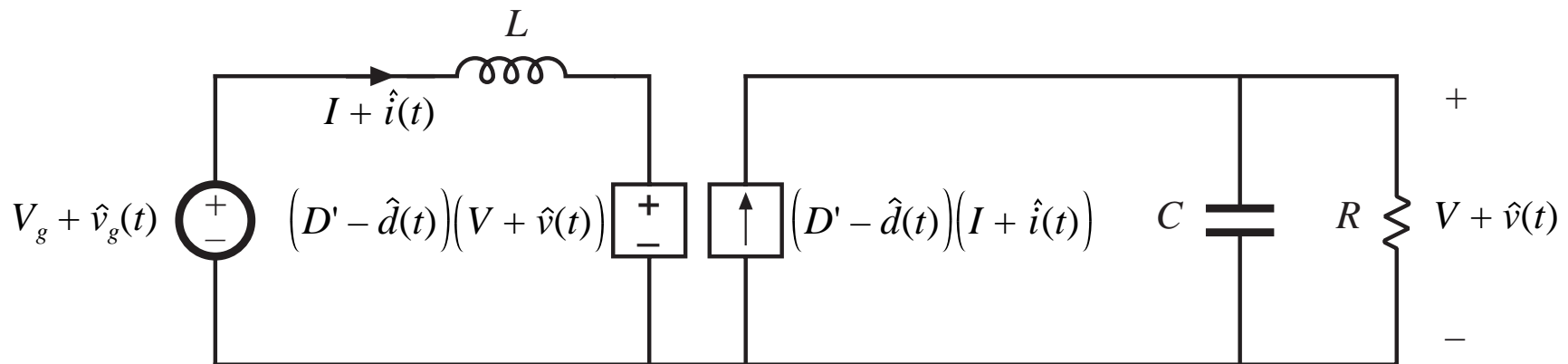

# Dependent voltage source

$$(D' - \hat{d}(t)) (V + \hat{v}(t)) = D' (V + \hat{v}(t)) - V \hat{d}(t) - \hat{v}(t) \hat{d}(t)$$

*nonlinear,  
2nd order*

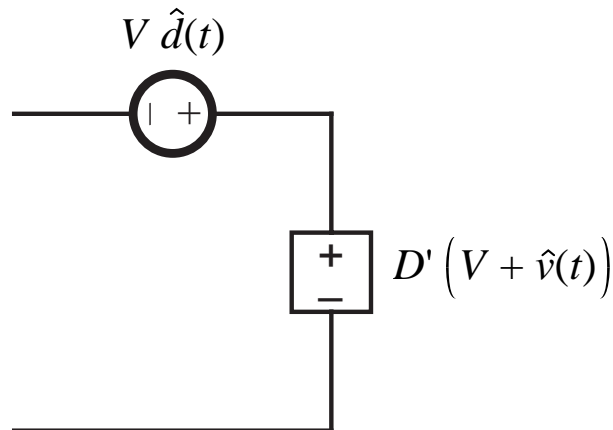

# Dependent current source

---

$$(D' - \hat{d}(t))(I + \hat{i}(t)) = D'(I + \hat{i}(t)) - I\hat{d}(t) - \hat{i}(t)\hat{d}(t)$$

*nonlinear,  
2nd order*

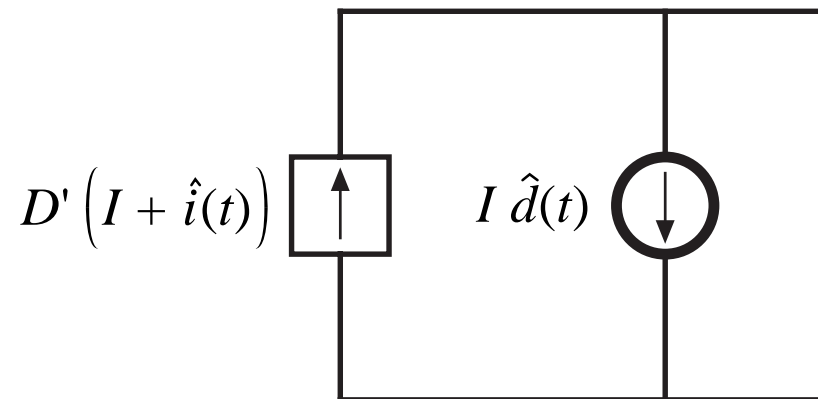

# Linearized circuit-averaged model

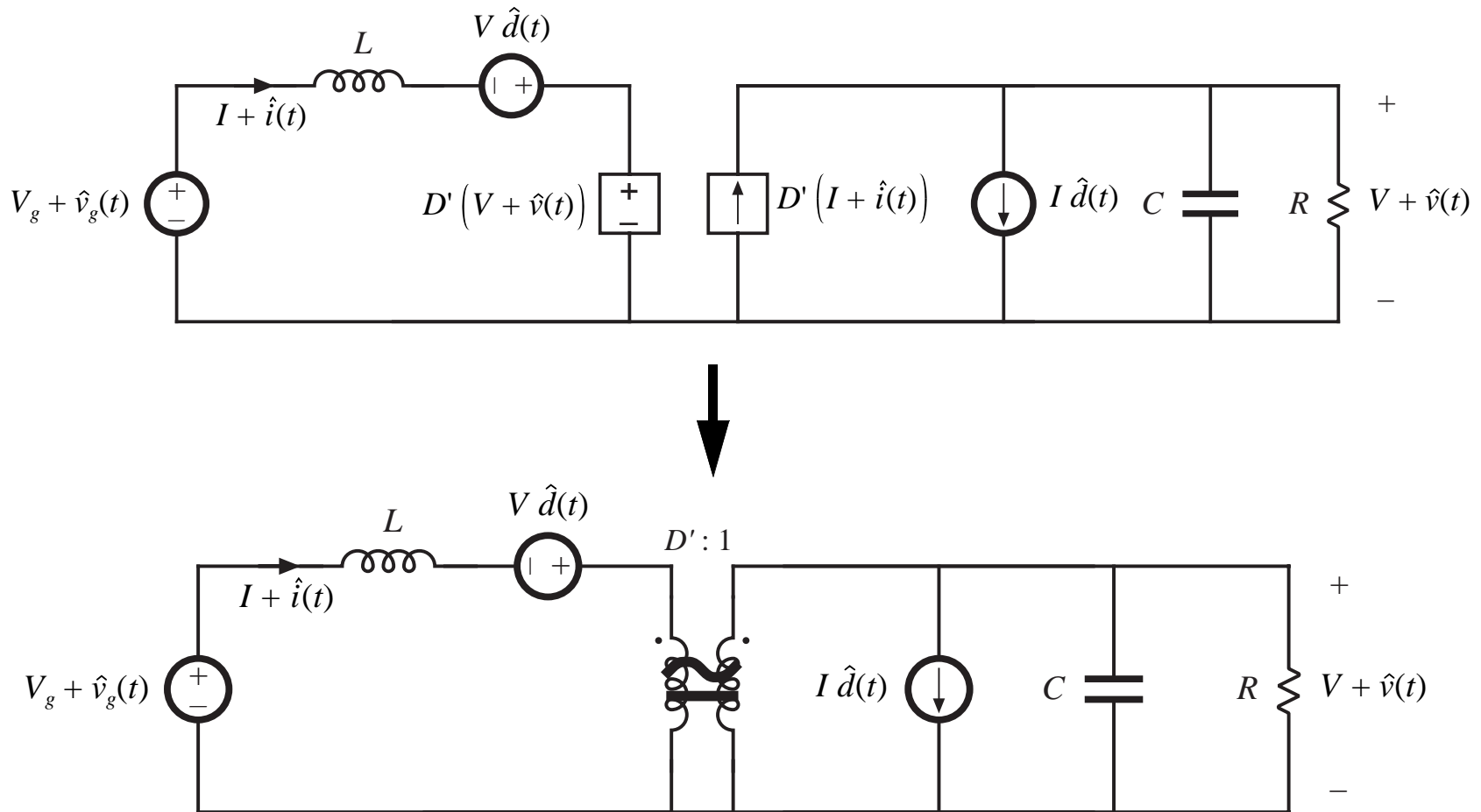

# Summary: Circuit averaging method

---

Model the switch network with equivalent voltage and current sources, such that an equivalent time-invariant network is obtained

Average converter waveforms over one switching period, to remove the switching harmonics

Perturb and linearize the resulting low-frequency model, to obtain a small-signal equivalent circuit

# Averaged switch modeling: CCM

*Circuit averaging of the boost converter: in essence, the switch network was replaced with an effective ideal transformer and generators:*

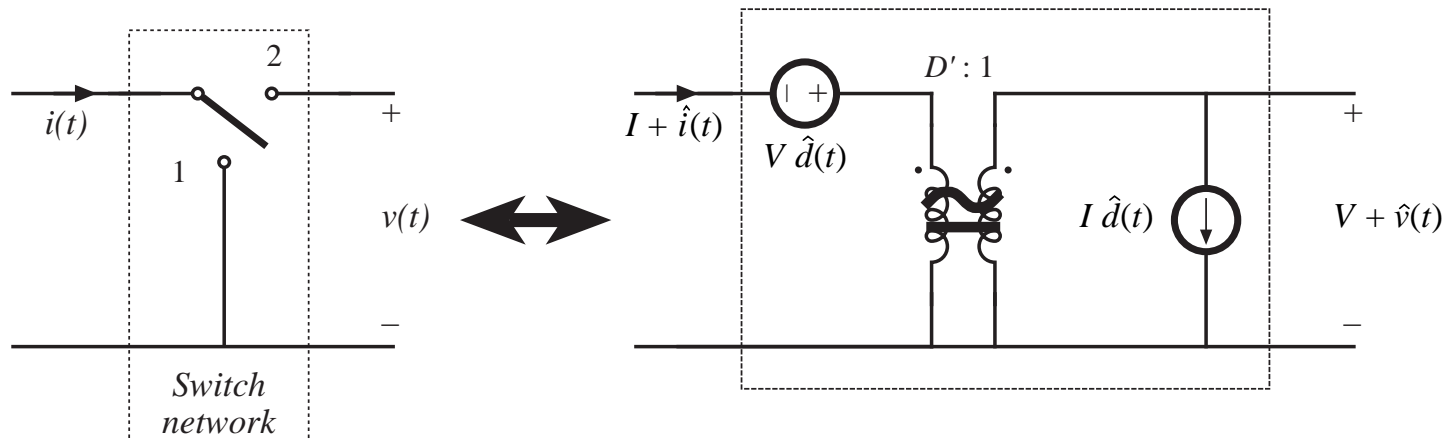

# Basic functions performed by switch network

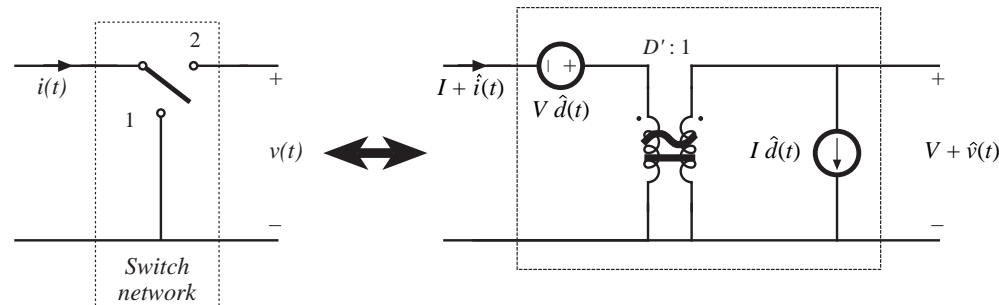

For the boost example, we can conclude that the switch network performs two basic functions:

- Transformation of dc and small-signal ac voltage and current levels, according to the  $D':1$  conversion ratio
- Introduction of ac voltage and current variations, drive by the control input duty cycle variations

Circuit averaging modifies only the switch network. Hence, to obtain a small-signal converter model, we need only replace the switch network with its averaged model. Such a procedure is called *averaged switch modeling*.



# Averaged switch modeling: Procedure

1. Define a switch network and its terminal waveforms. For a simple transistor-diode switch network as in the buck, boost, etc., there are two ports and four terminal quantities:  $v_1$ ,  $i_1$ ,  $v_2$ ,  $i_2$ . The switch network also contains a control input  $d$ . Buck example:

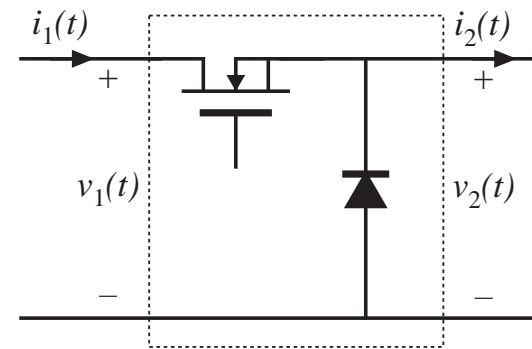

2. To derive an averaged switch model, express the average values of two of the terminal quantities, for example  $\langle v_2 \rangle_{T_s}$  and  $\langle i_1 \rangle_{T_s}$ , as functions of the other average terminal quantities  $\langle v_1 \rangle_{T_s}$  and  $\langle i_1 \rangle_{T_s}$ .  $\langle v_2 \rangle_{T_s}$  and  $\langle i_1 \rangle_{T_s}$  may also be functions of the control input  $d$ , but they should not be expressed in terms of other converter signals.

# The basic buck-type CCM switch cell

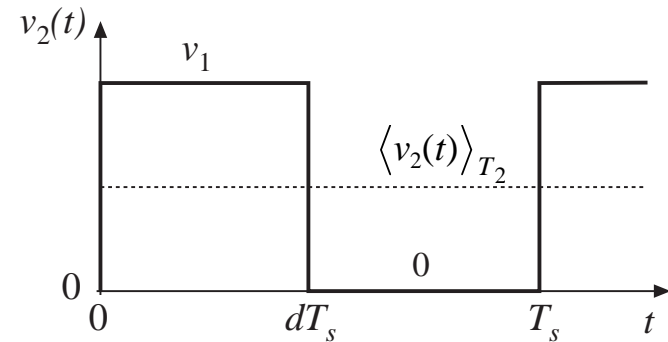
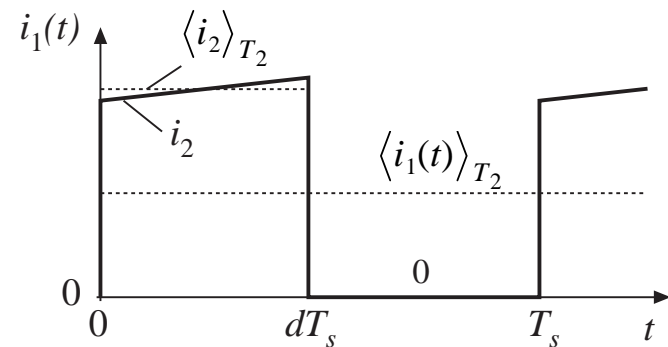
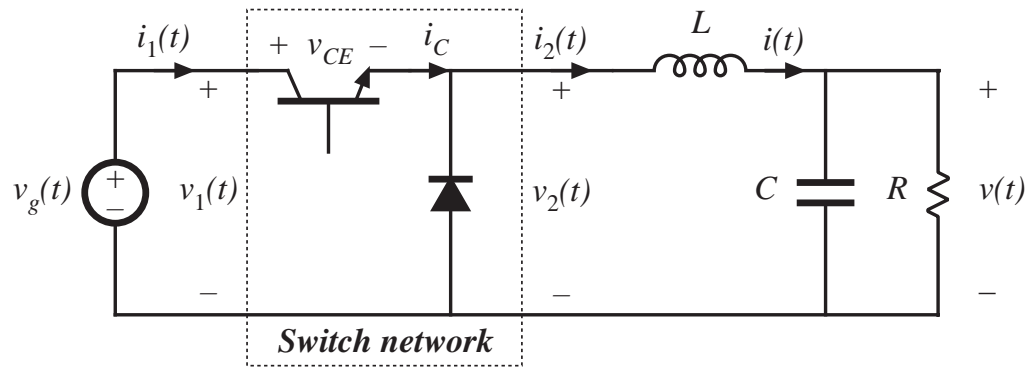

$$\langle i_1(t) \rangle_{T_s} = d(t) \langle i_2(t) \rangle_{T_s}$$

$$\langle v_2(t) \rangle_{T_s} = d(t) \langle v_1(t) \rangle_{T_s}$$

# Replacement of switch network by dependent sources, CCM buck example

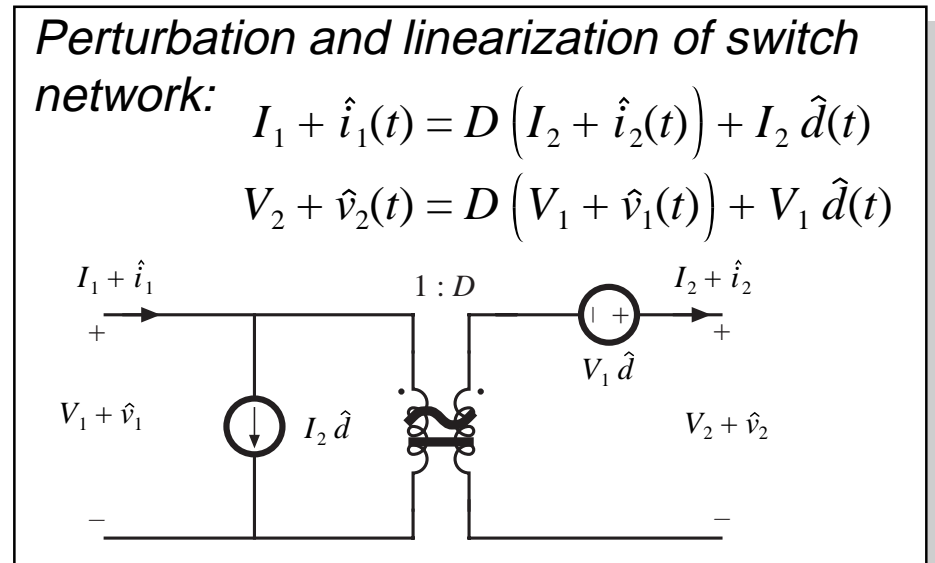
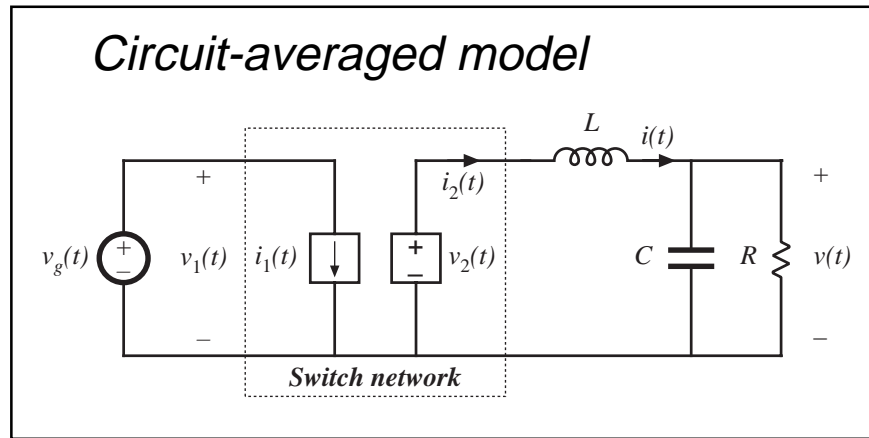

*Resulting averaged switch model: CCM buck converter*

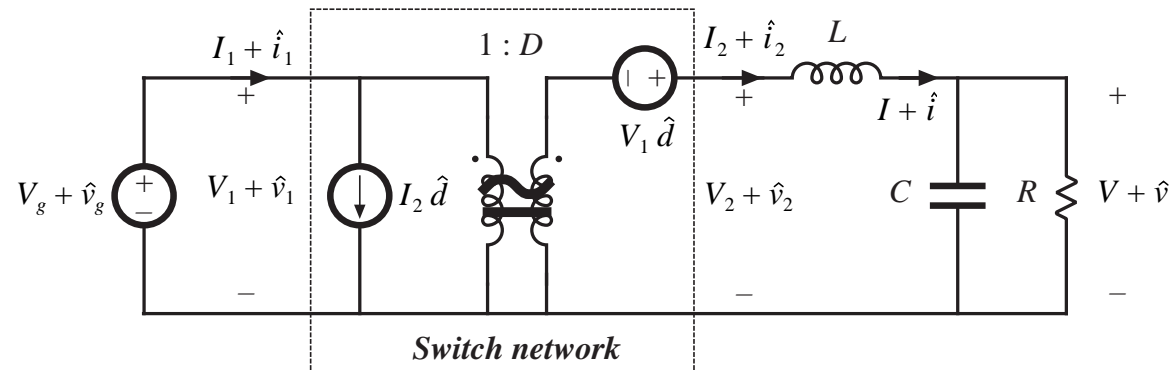

# Three basic switch networks, and their CCM dc and small-signal ac averaged switch models

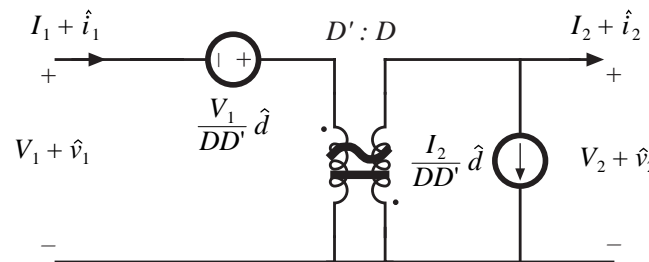
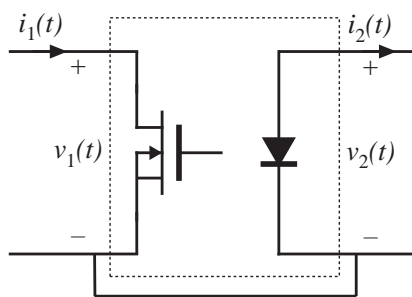
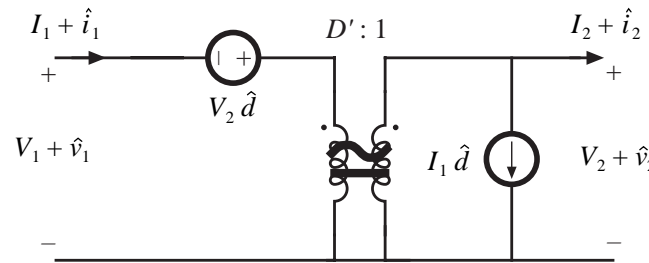
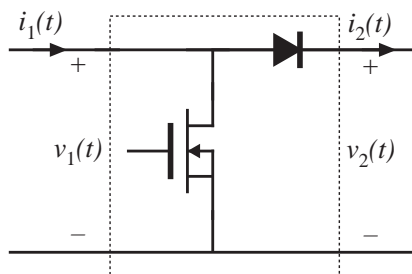
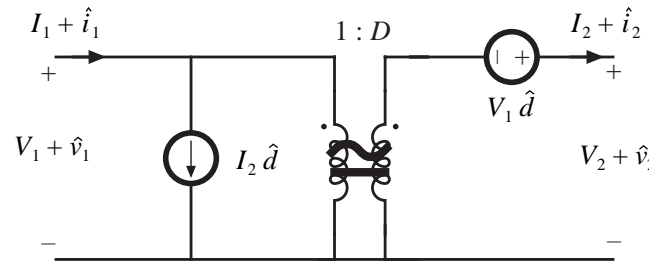
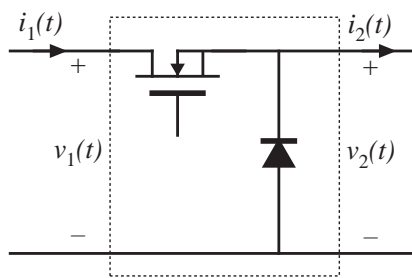

*see also*  
 Appendix 3  
 Averaged switch  
 modeling of a  
 CCM SEPIC

## Example: Averaged switch modeling of CCM buck converter, including switching loss

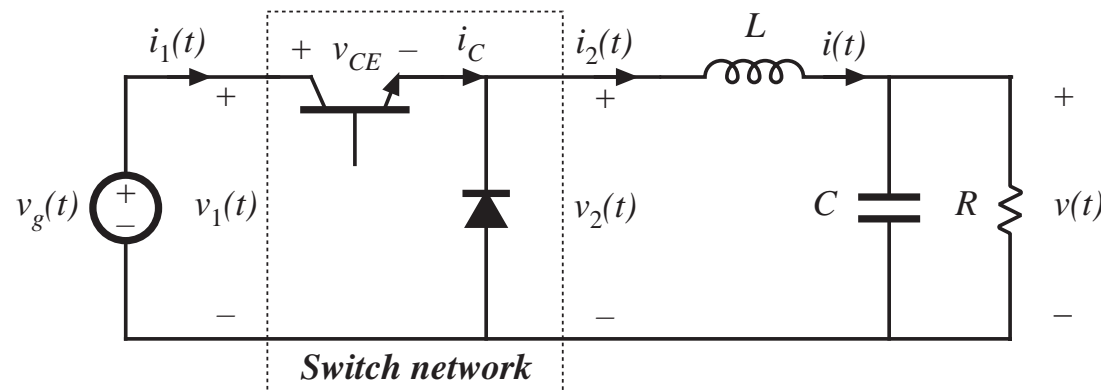

$$i_1(t) = i_C(t)$$

$$v_2(t) = v_1(t) - v_{CE}(t)$$

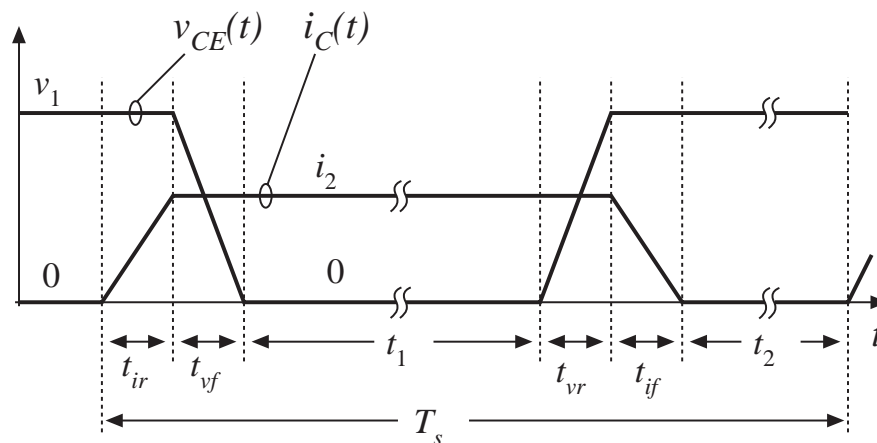

Switch network terminal waveforms:  $v_1, i_1, v_2, i_2$ . To derive averaged switch model, express  $\langle v_2 \rangle_{T_s}$  and  $\langle i_1 \rangle_{T_s}$  as functions of  $\langle v_1 \rangle_{T_s}$  and  $\langle i_1 \rangle_{T_s}$ .  $\langle v_2 \rangle_{T_s}$  and  $\langle i_1 \rangle_{T_s}$  may also be functions of the control input  $d$ , but they should not be expressed in terms of other converter signals.

# Averaging $i_1(t)$

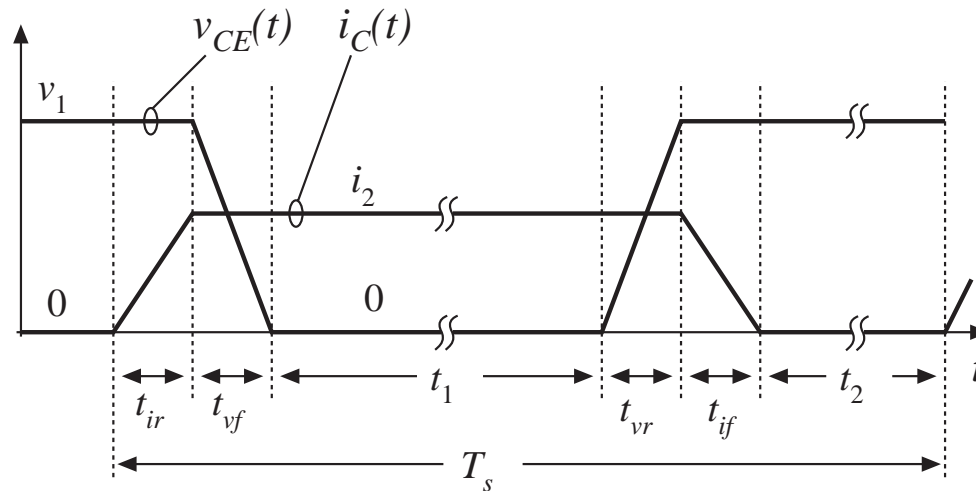

$$\begin{aligned} \langle i_1(t) \rangle_{T_s} &= \frac{1}{T_s} \int_0^{T_s} i_1(t) dt \\ &= \langle i_2(t) \rangle_{T_s} \left( \frac{t_1 + t_{vf} + t_{vr} + \frac{1}{2} t_{ir} + \frac{1}{2} t_{if}}{T_s} \right) \end{aligned}$$

## Expression for $\langle i_1(t) \rangle$

*Given*

$$\begin{aligned}\langle i_1(t) \rangle_{T_s} &= \frac{1}{T_s} \int_0^{T_s} i_1(t) dt \\ &= \langle i_2(t) \rangle_{T_s} \left( \frac{t_1 + t_{vf} + t_{vr} + \frac{1}{2} t_{ir} + \frac{1}{2} t_{if}}{T_s} \right)\end{aligned}$$

*Let*

$$d = \left( \frac{t_1 + \frac{1}{2} t_{vf} + \frac{1}{2} t_{vr} + \frac{1}{2} t_{ir} + \frac{1}{2} t_{if}}{T_s} \right)$$

$$d_v = \left( \frac{t_{vf} + t_{vr}}{T_s} \right)$$

$$d_i = \left( \frac{t_{ir} + t_{if}}{T_s} \right)$$

*Then we can write*

$$\langle i_1(t) \rangle_{T_s} = \langle i_2(t) \rangle_{T_s} \left( d + \frac{1}{2} d_v \right)$$

## Averaging the switch network output voltage $v_2(t)$

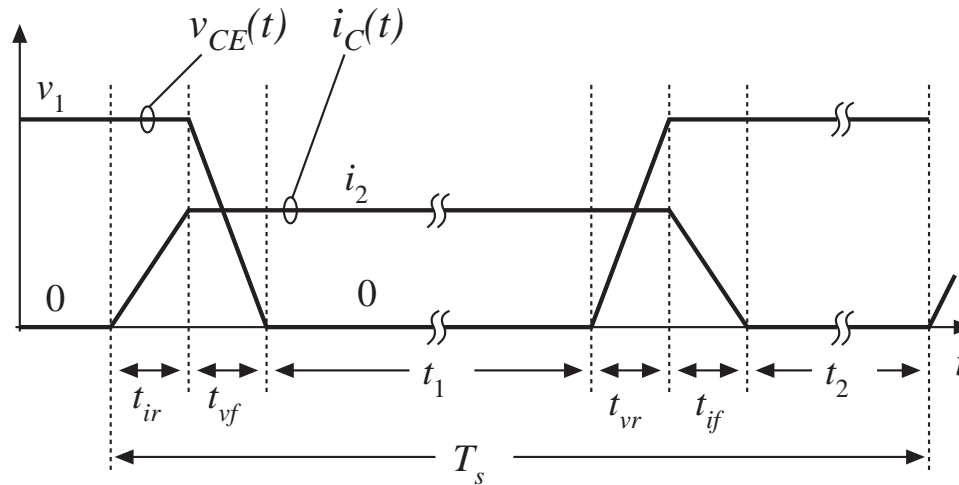

$$\langle v_2(t) \rangle_{T_s} = \langle v_1(t) - v_{CE}(t) \rangle_{T_s} = \frac{1}{T_s} \int_0^{T_s} (-v_{CE}(t)) dt + \langle v_1(t) \rangle_{T_s}$$

$$\langle v_2(t) \rangle_{T_s} = \langle v_1(t) \rangle_{T_s} \left( \frac{t_1 + \frac{1}{2} t_{vf} + \frac{1}{2} t_{vr}}{T_s} \right)$$

$$\langle v_2(t) \rangle_{T_s} = \langle v_1(t) \rangle_{T_s} \left( d - \frac{1}{2} d_i \right)$$



# Construction of large-signal averaged-switch model

$$\langle i_1(t) \rangle_{T_s} = \langle i_2(t) \rangle_{T_s} \left( d + \frac{1}{2} d_v \right) \quad \langle v_2(t) \rangle_{T_s} = \langle v_1(t) \rangle_{T_s} \left( d - \frac{1}{2} d_i \right)$$

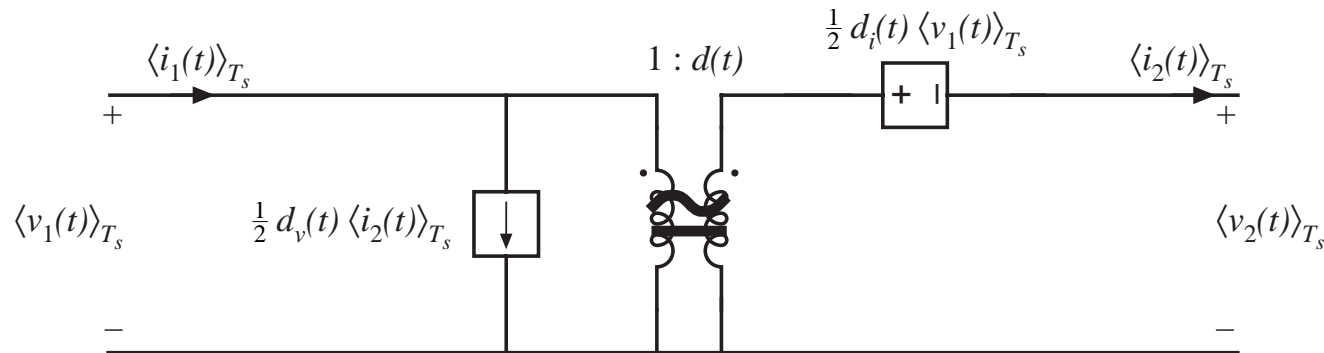
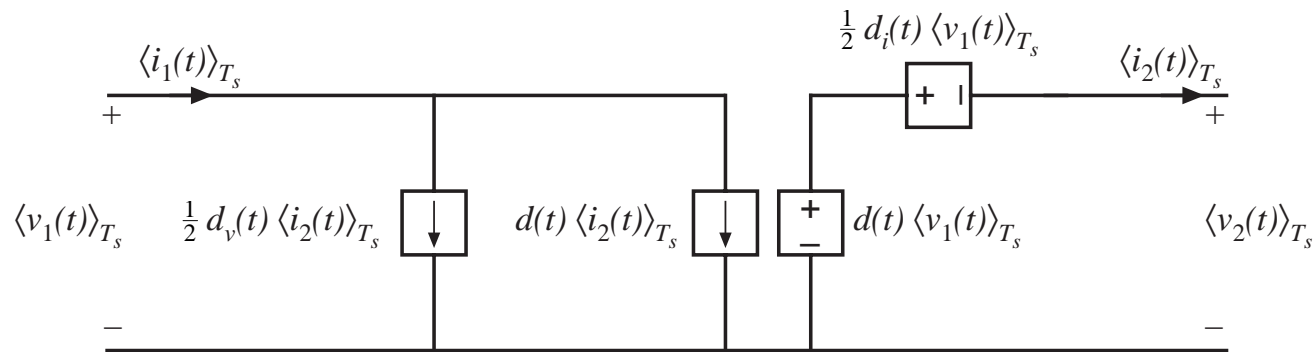

# Switching loss predicted by averaged switch model

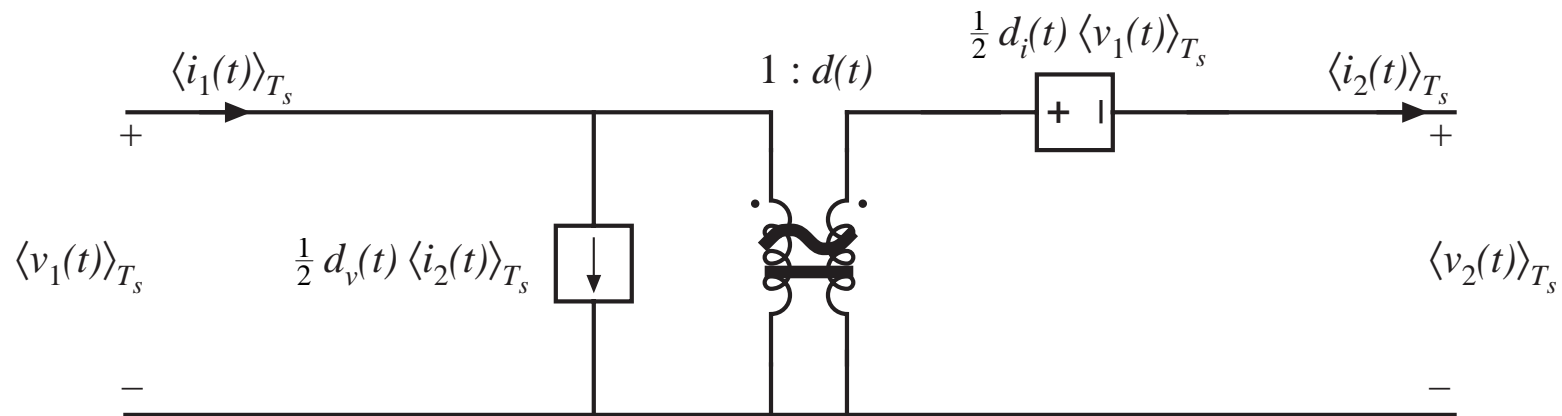

$$P_{sw} = \frac{1}{2} (d_v + d_i) \langle i_2(t) \rangle_{T_s} \langle v_1(t) \rangle_{T_s}$$

# Solution of averaged converter model in steady state

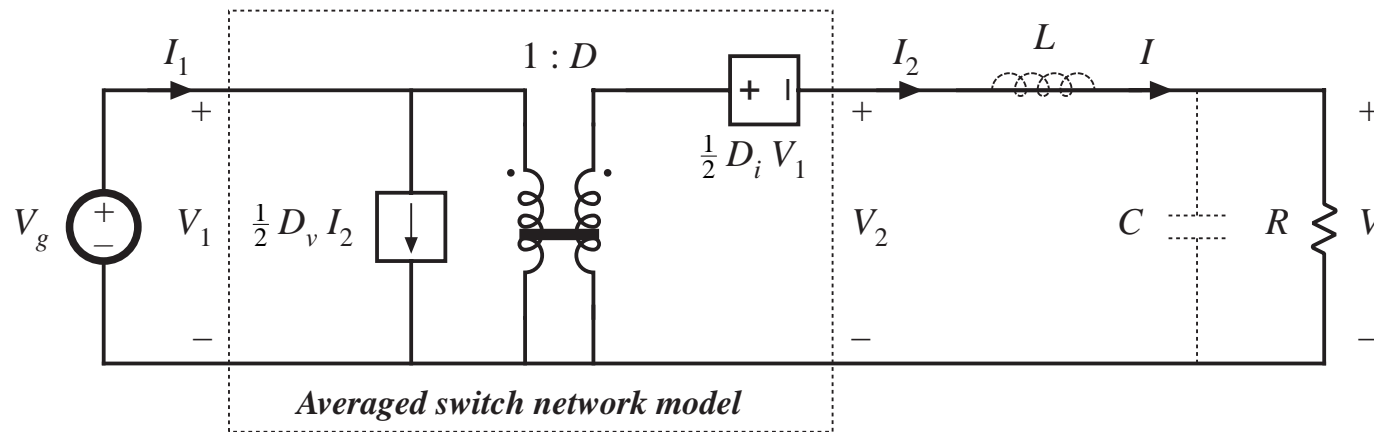

*Output voltage:*

$$V = \left( D - \frac{1}{2} D_i \right) V_g = D V_g \left( 1 - \frac{D_i}{2D} \right)$$

*Efficiency calculation:*

$$P_{in} = V_g I_1 = V_1 I_2 \left( D + \frac{1}{2} D_v \right)$$

$$P_{out} = V I_2 = V_1 I_2 \left( D - \frac{1}{2} D_i \right)$$

$$\eta = \frac{P_{out}}{P_{in}} = \frac{\left( D - \frac{1}{2} D_i \right)}{\left( D + \frac{1}{2} D_v \right)} = \frac{\left( 1 - \frac{D_i}{2D} \right)}{\left( 1 + \frac{D_v}{2D} \right)}$$

## 7.6. The canonical circuit model

---

All PWM CCM dc-dc converters perform the same basic functions:

- Transformation of voltage and current levels, ideally with 100% efficiency
- Low-pass filtering of waveforms
- Control of waveforms by variation of duty cycle

Hence, we expect their equivalent circuit models to be qualitatively similar.

Canonical model:

- A standard form of equivalent circuit model, which represents the above physical properties
- Plug in parameter values for a given specific converter

## 7.6.1. Development of the canonical circuit model

### 1. Transformation of dc voltage and current levels

- modeled as in Chapter 3 with ideal dc transformer
- effective turns ratio  $M(D)$
- can refine dc model by addition of effective loss elements, as in Chapter 3

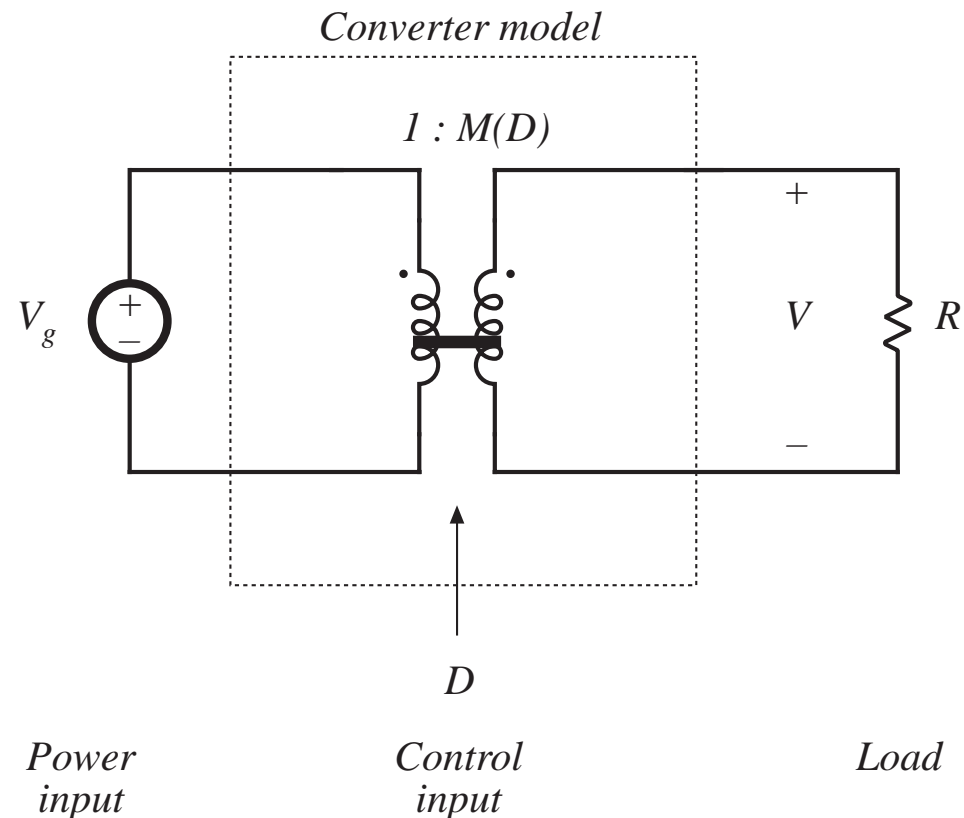

# Steps in the development of the canonical circuit model

2. *Ac variations in  $v_g(t)$  induce ac variations in  $v(t)$*
- *these variations are also transformed by the conversion ratio  $M(D)$*

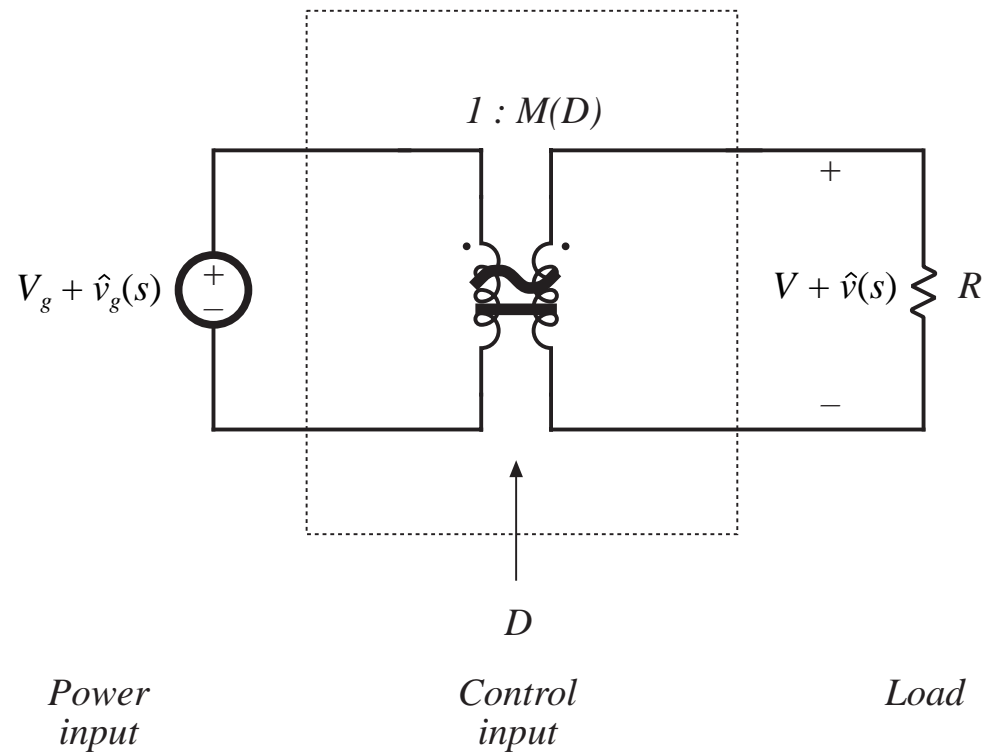

# Steps in the development of the canonical circuit model

3. Converter must contain an effective low-pass filter characteristic

- necessary to filter switching ripple
- also filters ac variations
- effective filter elements may not coincide with actual element values, but can also depend on operating point

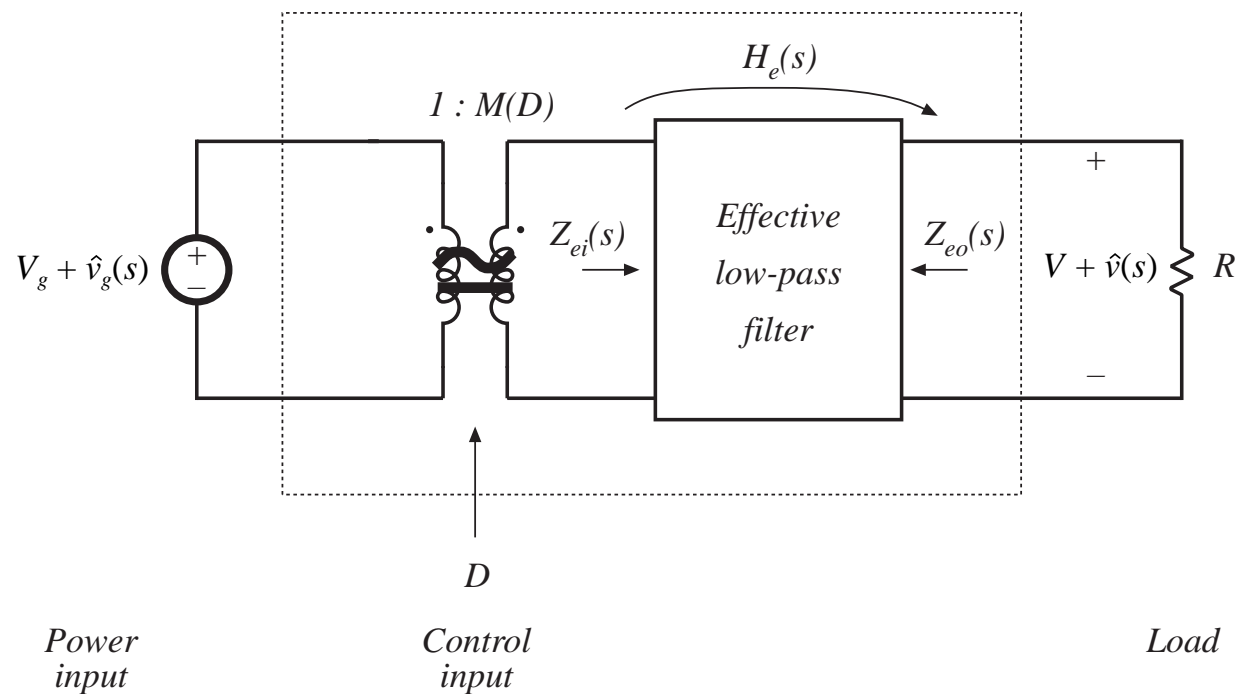

# Steps in the development of the canonical circuit model

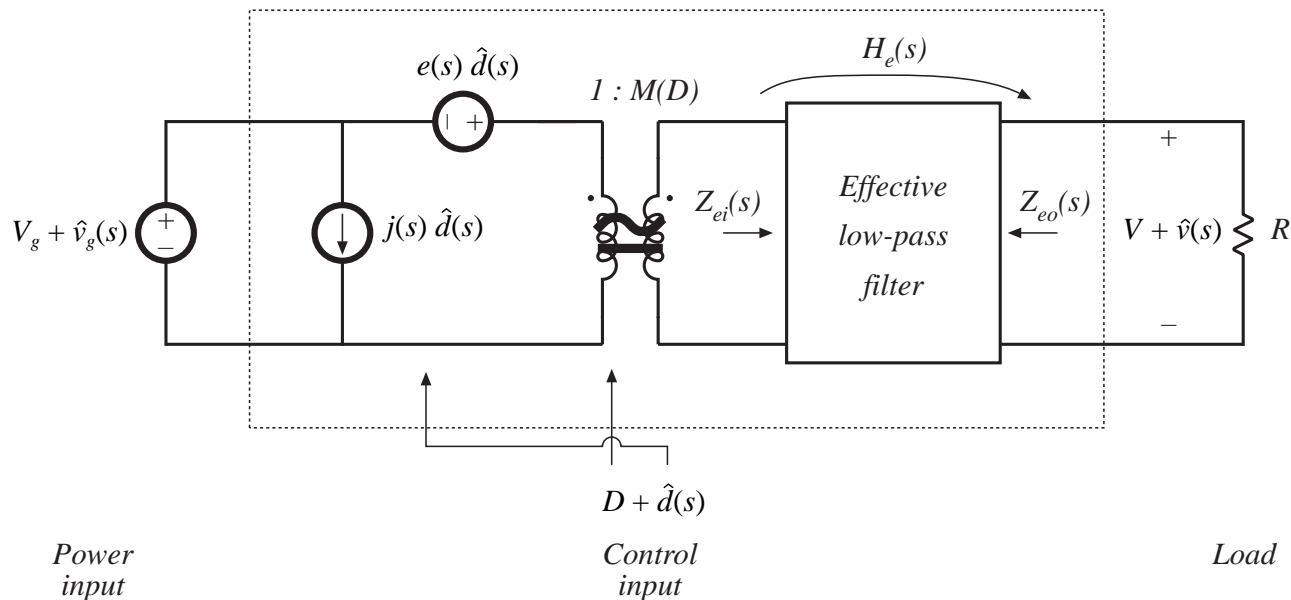

4. *Control input variations also induce ac variations in converter waveforms*
  - *Independent sources represent effects of variations in duty cycle*
  - *Can push all sources to input side as shown. Sources may then become frequency-dependent*



# Transfer functions predicted by canonical model

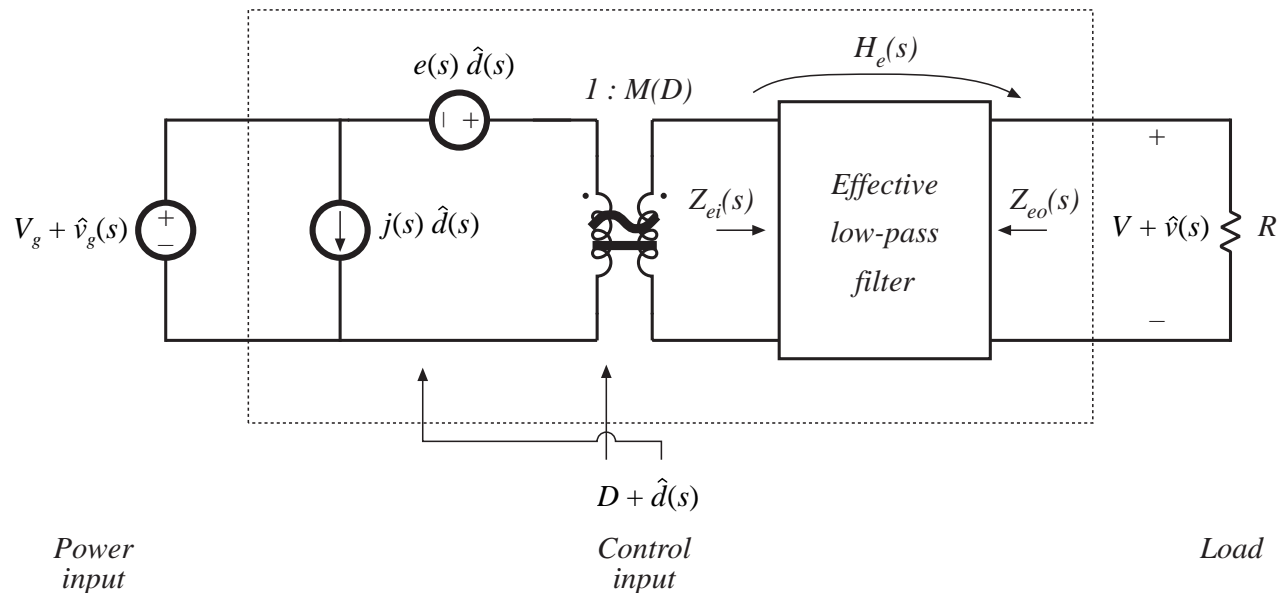

Line-to-output transfer function:

$$G_{vg}(s) = \frac{\hat{v}(s)}{\hat{v}_g(s)} = M(D) H_e(s)$$

Control-to-output transfer function:

$$G_{vd}(s) = \frac{\hat{v}(s)}{\hat{d}(s)} = e(s) M(D) H_e(s)$$

## 7.6.2. Example: manipulation of the buck-boost converter model into canonical form

*Small-signal ac model of the buck-boost converter*

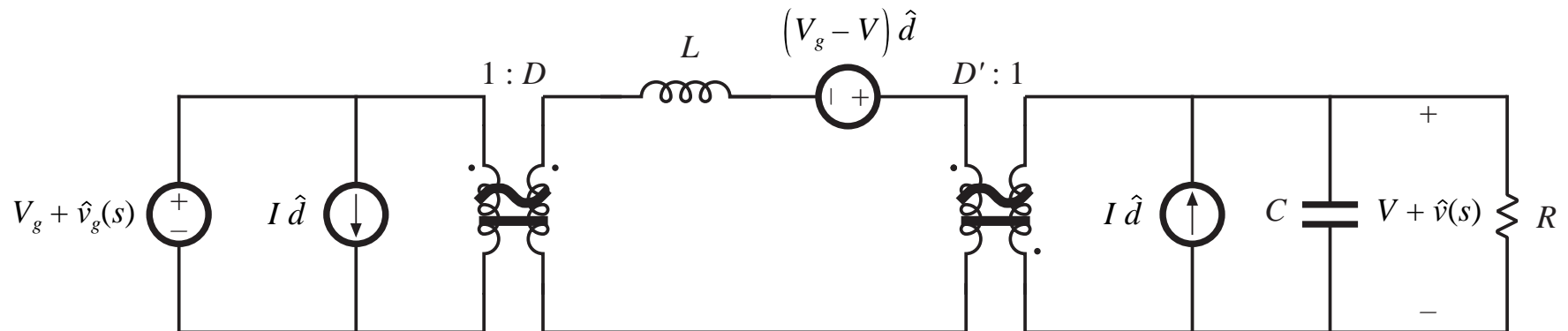

- Push independent sources to input side of transformers
- Push inductor to output side of transformers
- Combine transformers

# Step 1

*Push voltage source through 1:D transformer  
Move current source through D':1 transformer*

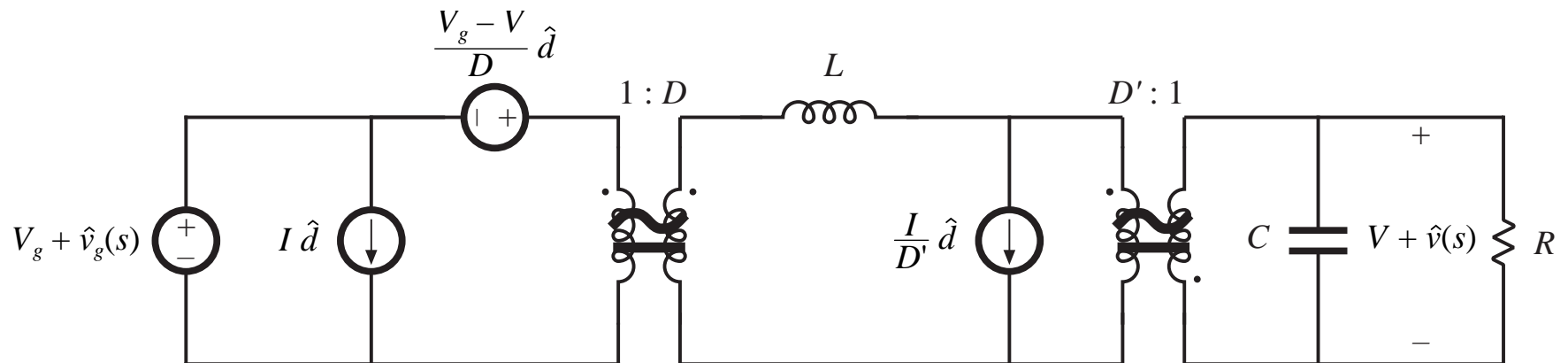

## Step 2

*How to move the current source past the inductor:*

*Break ground connection of current source, and connect to node A instead.*

*Connect an identical current source from node A to ground, so that the node equations are unchanged.*

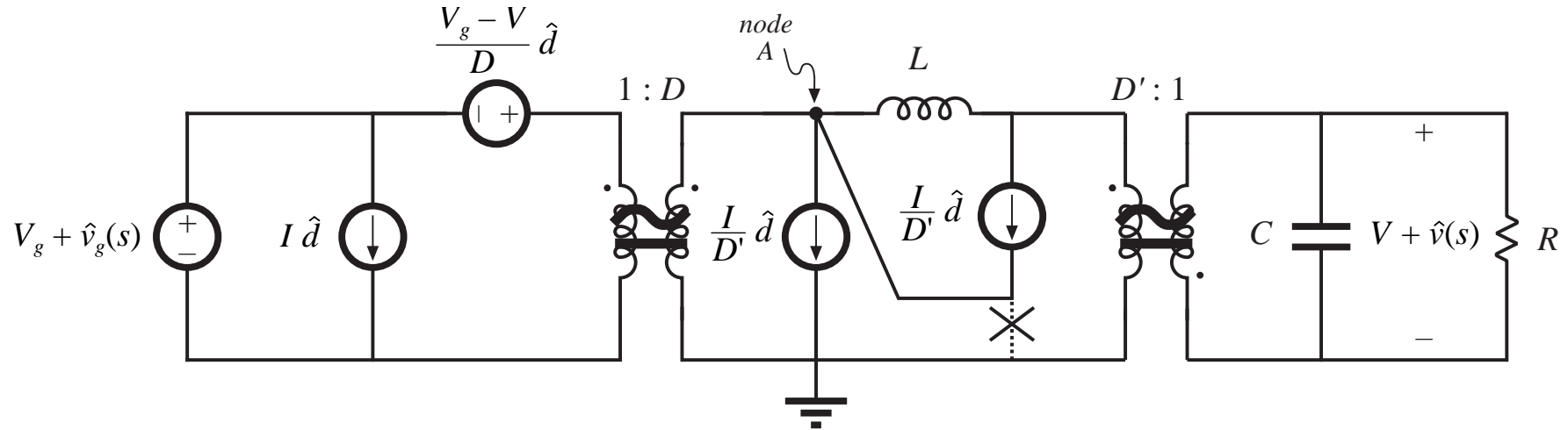

## Step 3

*The parallel-connected current source and inductor can now be replaced by a Thevenin-equivalent network:*

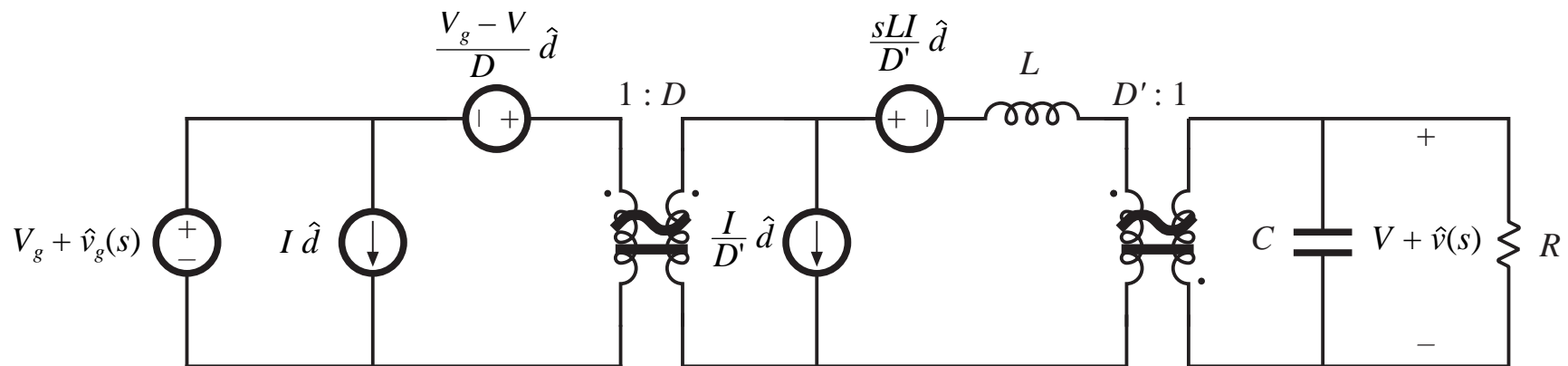

## Step 4

Now push current source through  $1:D$  transformer.

Push current source past voltage source, again by:

Breaking ground connection of current source, and connecting to node B instead.

Connecting an identical current source from node B to ground, so that the node equations are unchanged.

Note that the resulting parallel-connected voltage and current sources are equivalent to a single voltage source.

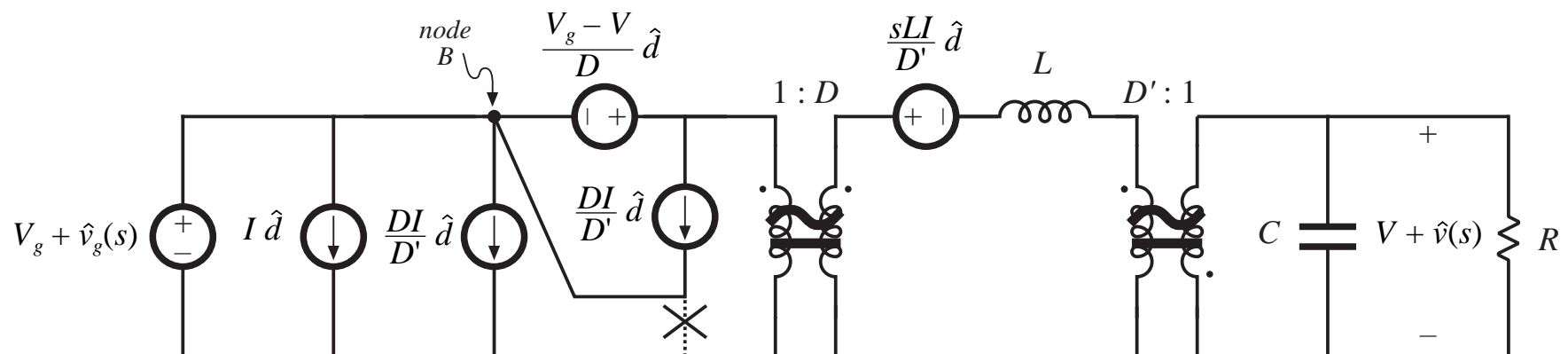

## Step 5: final result

*Push voltage source through 1:D transformer, and combine with existing input-side transformer.*

*Combine series-connected transformers.*

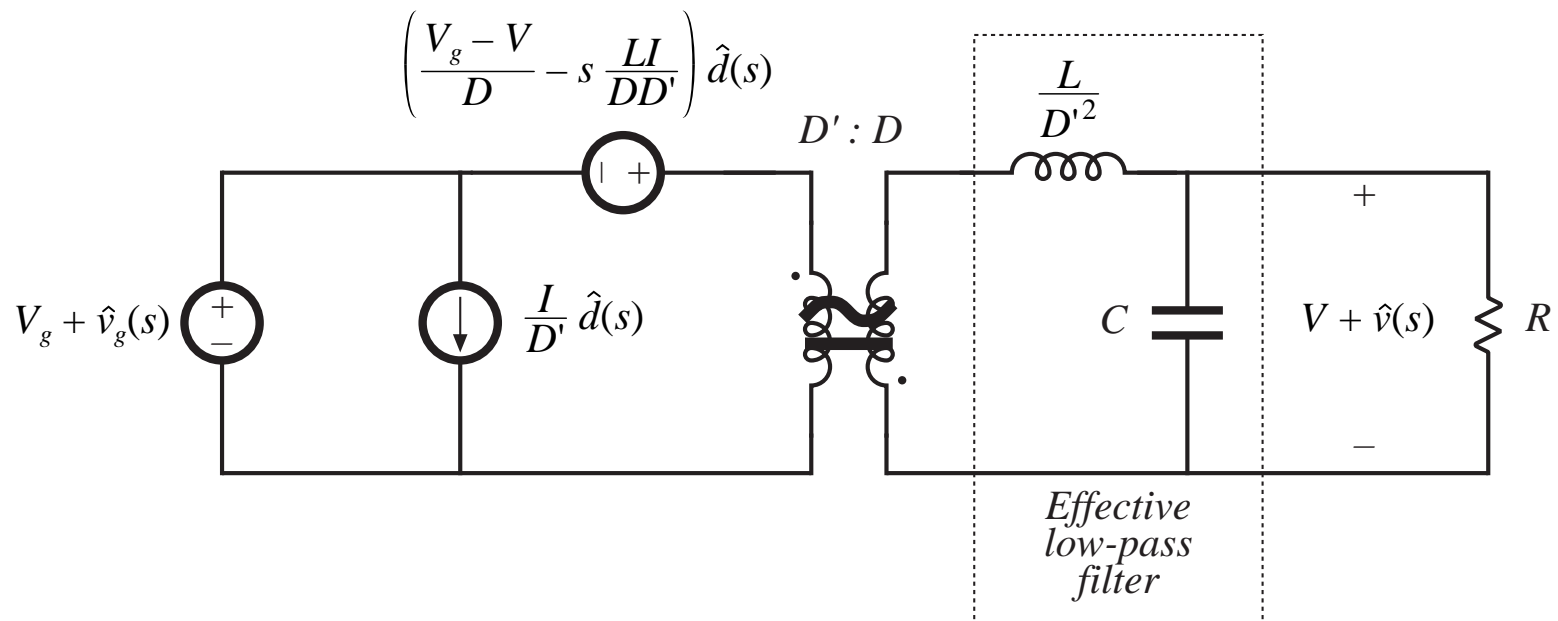

# Coefficient of control-input voltage generator

---

Voltage source coefficient is:

$$e(s) = \frac{V_g + V}{D} - \frac{s LI}{D D'}$$

Simplification, using dc relations, leads to

$$e(s) = -\frac{V}{D^2} \left( 1 - \frac{s DL}{D'^2 R} \right)$$

Pushing the sources past the inductor causes the generator to become frequency-dependent.



## 7.6.3. Canonical circuit parameters for some common converters

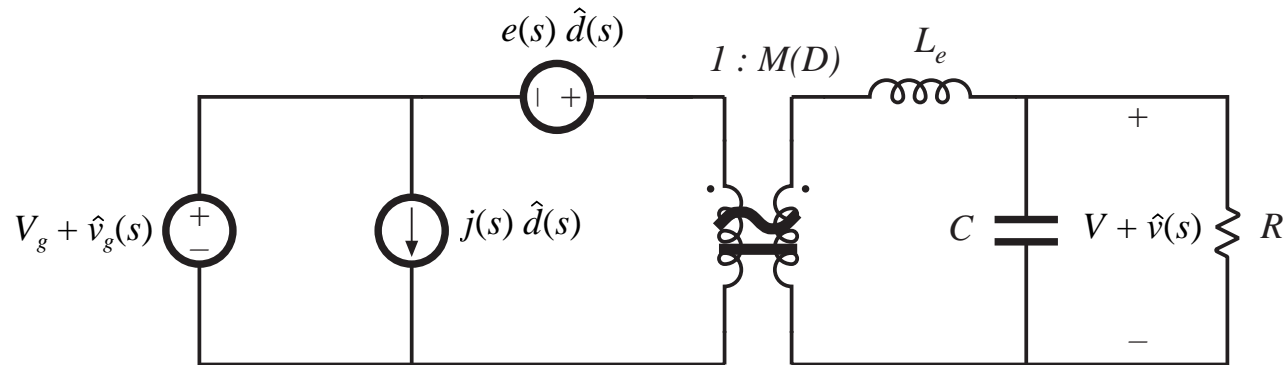

Table 7.1. Canonical model parameters for the ideal buck, boost, and buck-boost converters

Converter	$M(D)$	$L_e$	$e(s)$	$j(s)$
Buck	$D$	$L$	$\frac{V}{D^2}$	$\frac{V}{R}$
Boost	$\frac{1}{D'}$	$\frac{L}{D'^2}$	$V \left( 1 - \frac{sL}{D'^2 R} \right)$	$\frac{V}{D'^2 R}$
Buck-boost	$-\frac{D}{D'}$	$\frac{L}{D'^2}$	$-\frac{V}{D^2} \left( 1 - \frac{sDL}{D'^2 R} \right)$	$-\frac{V}{D'^2 R}$

## 7.7. Modeling the pulse-width modulator

Pulse-width modulator converts voltage signal  $v_c(t)$  into duty cycle signal  $d(t)$ .

What is the relation between  $v_c(t)$  and  $d(t)$ ?

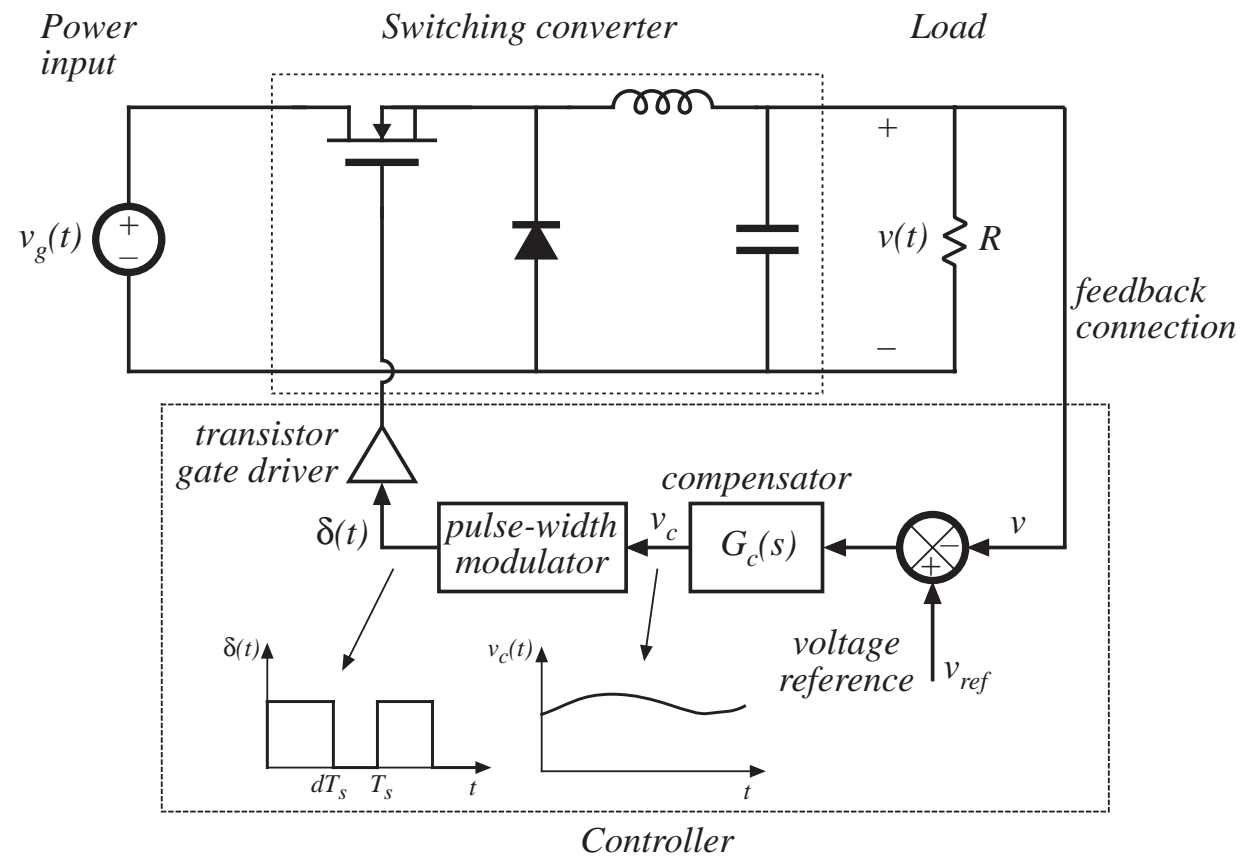

# A simple pulse-width modulator

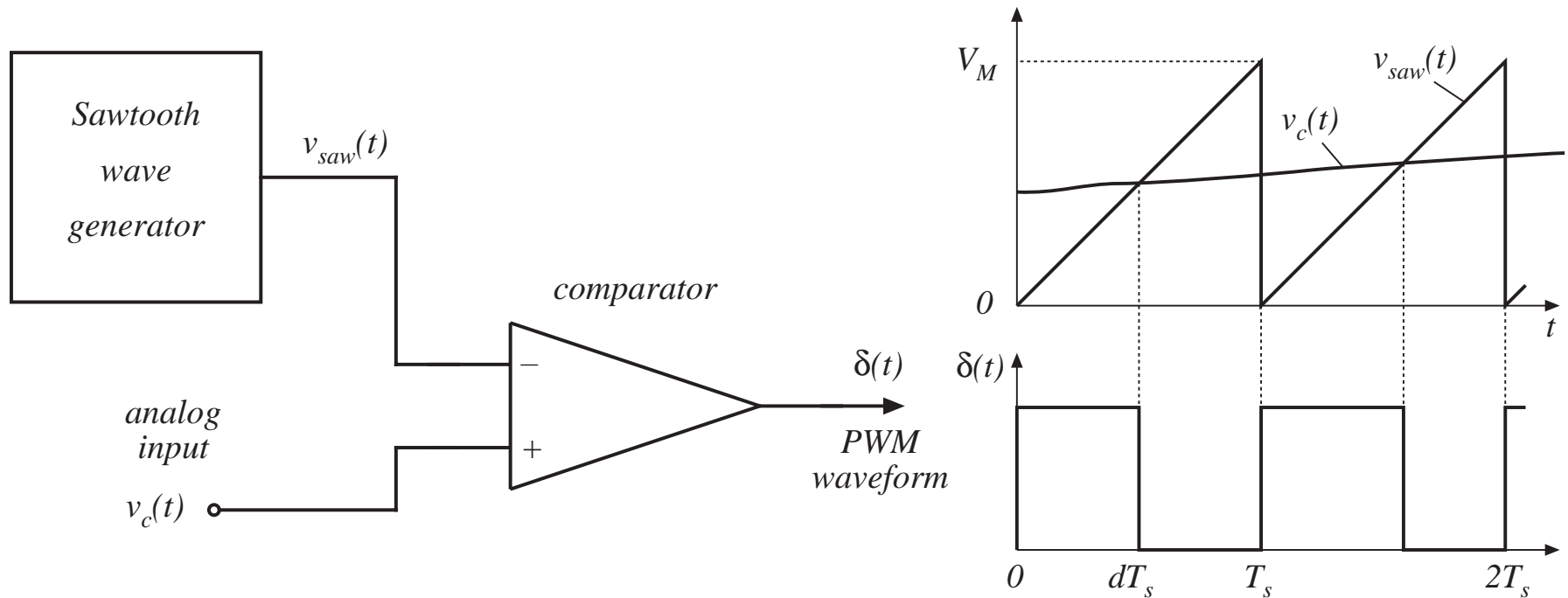

# Equation of pulse-width modulator

For a linear sawtooth waveform:

$$d(t) = \frac{v_c(t)}{V_M} \quad \text{for } 0 \leq v_c(t) \leq V_M$$

So  $d(t)$  is a linear function of  $v_c(t)$ .

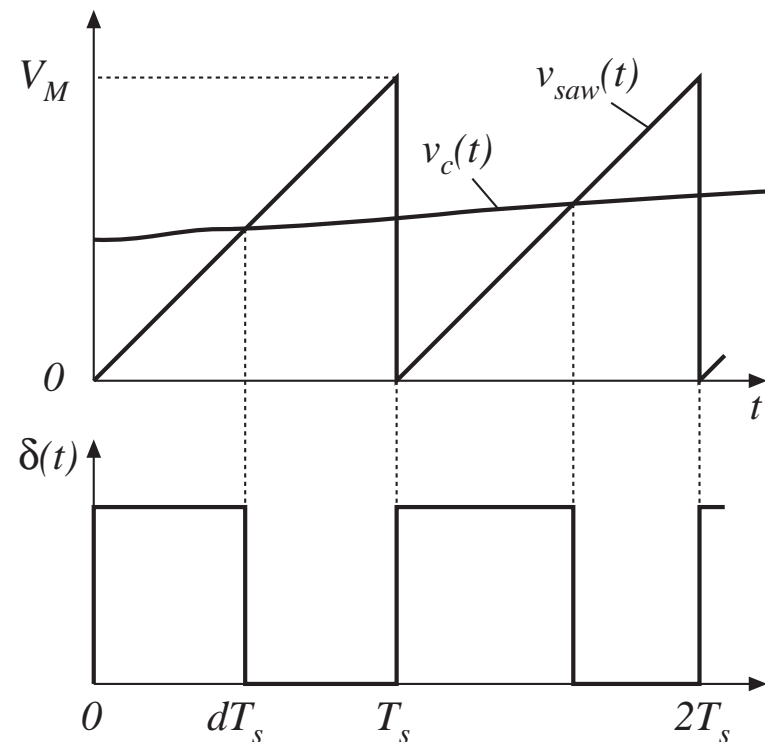

# Perturbed equation of pulse-width modulator

PWM equation:

$$d(t) = \frac{v_c(t)}{V_M} \quad \text{for } 0 \leq v_c(t) \leq V_M$$

Perturb:

$$v_c(t) = V_c + \hat{v}_c(t)$$

$$d(t) = D + \hat{d}(t)$$

Result:

$$D + \hat{d}(t) = \frac{V_c + \hat{v}_c(t)}{V_M}$$

Block diagram:

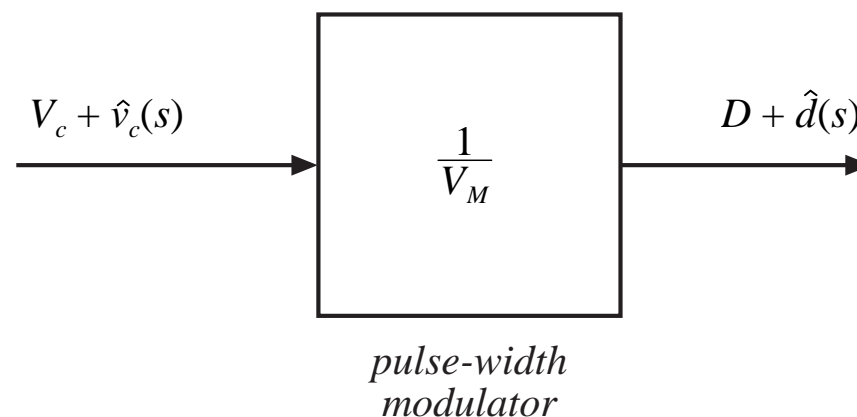

Dc and ac relations:

$$D = \frac{V_c}{V_M}$$

$$\hat{d}(t) = \frac{\hat{v}_c(t)}{V_M}$$

# Sampling in the pulse-width modulator

The input voltage is a continuous function of time, but there can be only one discrete value of the duty cycle for each switching period.

Therefore, the pulse-width modulator samples the control waveform, with sampling rate equal to the switching frequency.

In practice, this limits the useful frequencies of ac variations to values much less than the switching frequency. Control system bandwidth must be sufficiently less than the Nyquist rate  $f_s/2$ . Models that do not account for sampling are accurate only at frequencies much less than  $f_s/2$ .

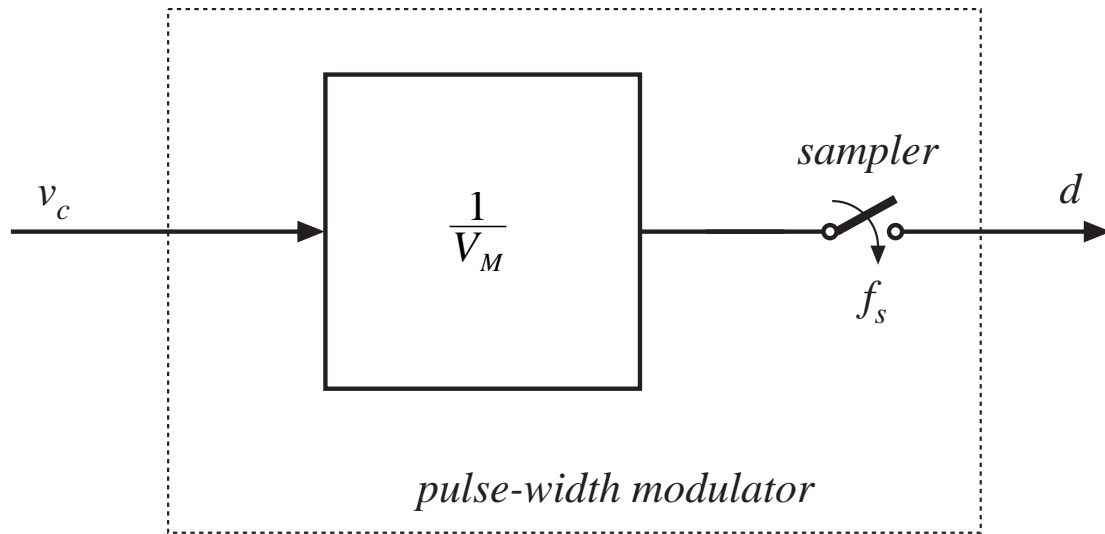

## 7.8. Summary of key points

---

1. The CCM converter analytical techniques of Chapters 2 and 3 can be extended to predict converter ac behavior. The key step is to average the converter waveforms over one switching period. This removes the switching harmonics, thereby exposing directly the desired dc and low-frequency ac components of the waveforms. In particular, expressions for the averaged inductor voltages, capacitor currents, and converter input current are usually found.
2. Since switching converters are nonlinear systems, it is desirable to construct small-signal linearized models. This is accomplished by perturbing and linearizing the averaged model about a quiescent operating point.
3. Ac equivalent circuits can be constructed, in the same manner used in Chapter 3 to construct dc equivalent circuits. If desired, the ac equivalent circuits may be refined to account for the effects of converter losses and other nonidealities.

# Summary of key points

---

4. The state-space averaging method of section 7.4 is essentially the same as the basic approach of section 7.2, except that the formality of the state-space network description is used. The general results are listed in section 7.4.2.
5. The circuit averaging technique also yields equivalent results, but the derivation involves manipulation of circuits rather than equations. Switching elements are replaced by dependent voltage and current sources, whose waveforms are defined to be identical to the switch waveforms of the actual circuit. This leads to a circuit having a time-invariant topology. The waveforms are then averaged to remove the switching ripple, and perturbed and linearized about a quiescent operating point to obtain a small-signal model.



## Summary of key points

---

6. When the switches are the only time-varying elements in the converter, then circuit averaging affects only the switch network. The converter model can then be derived by simply replacing the switch network with its averaged model. Dc and small-signal ac models of several common CCM switch networks are listed in section 7.5.4. Switching losses can also be modeled using this approach.

7. The canonical circuit describes the basic properties shared by all dc-dc PWM converters operating in the continuous conduction mode. At the heart of the model is the ideal  $1:M(D)$  transformer, introduced in Chapter 3 to represent the basic dc-dc conversion function, and generalized here to include ac variations. The converter reactive elements introduce an effective low-pass filter into the network. The model also includes independent sources which represent the effect of duty cycle variations. The parameter values in the canonical models of several basic converters are tabulated for easy reference.

# Summary of key points

---

8. The conventional pulse-width modulator circuit has linear gain, dependent on the slope of the sawtooth waveform, or equivalently on its peak-to-peak magnitude.