

ECEN5807

Modeling and Control of Power Electronic Systems

- **Instructor:** Dragan Maksimovic
 - Office: OT346, phone: 303-492-4863, fax: 303-492-2758
 - E-mail: maksimov@colorado.edu
 - Office hours
 - Wednesday 9-10am (Mountain), on-campus students have priority
 - Wednesday 10-11am (Mountain), off-campus students (telephone) have priority
 - Email questions will be answered within 24 hours (working days). Please use 5807 in the subject line
- **Course web site:**
 - <http://ecee.colorado.edu/~ecen5807>
 - Announcements, course materials, assignments, solutions, blog, CULearn,...
- **Textbook:**
 - Erickson and Maksimovic, *Fundamentals of Power Electronics*, 2nd edition, Springer 2000
- **On-line course lectures:**
 - Accessible through CAETE

Required Software

- Spice simulator
 - free LTspice is a recommended Spice simulator
- MATLAB/Simulink + Control Systems Toolbox
 - (\$99 student version is sufficient), and
 - Simulink Control Design (\$29 add-on with the student version)

Software is available to on-campus students on Power Lab and Circuits Lab computers

The course website includes relevant links to LTspice and MATLAB/Simulink

Assignments

- Weekly homeworks (12-13 total), 40% of the grade
HW1 will be assigned on Friday this week
- Midterm exam (open book/notes, take-home), 20% of the grade
- Final exam (comprehensive, open book/notes, take-home), 40% of the grade
- All assignments, due dates, and solutions posted on the course web site
- Late work will not be accepted except in cases of documented emergencies
- HW and exam scores will be posted during the semester via the CULearn system (linked on the course website)

Notes for off-campus students: due dates

- Due dates published on the course website are due dates for on-campus students (and CAETE students attending the lectures live)
- One week grace period is allowed to off-campus students: work must be received by the instructor by 5pm Mountain time no more than one week after the on-campus due date

Notes for off-campus students: ways to turn in your work

- Electronically, via the CULearn system

Scan your work using 1-bit black and white, at 150-200 dpi, with all pages in a single relatively small pdf file; if the file doesn't print quickly and correctly on printers available to the instructor and the graders, you will be required to transmit your assignments via other means

On-campus students can use this method as well

- Mail your work to:

Prof. Dragan Maksimovic
Campus Box 425
ECEE Department
University of Colorado
Boulder, CO 80309-0425
303-492-4863

- Fax your work to: 303-492-2758 (shared ECEE department machine)

List Prof. Maksimovic/ECEN5807 as the recipient

Keep a copy of your work!

ECEN5807 blog

- Linked on the course website
- You will receive an invitation to contribute to the blog via e-mail

ECEN5807 Spring 2011

Blog for students taking ECEN5807 Modeling and Control of Power Electronics, ECEE Department, University of Colorado at Boulder, Spring 2011

SUNDAY, DECEMBER 26, 2010

Welcome to ECEN5807 Spring 2011 blog

The purpose of this blog is to encourage and enable both on-campus and off-campus students to post questions, comments, ideas, discussions or pointers to on-line resources related to course materials and homework assignments. The instructor will *not* moderate or edit the blogs (except in cases of course policy violations), so you should *not* assume that any comments or ideas posted here have been approved, verified for correctness, or endorsed by the instructor. Course announcements, materials, solutions, etc. by the instructor will be discussed in lectures and posted on the course website, not on this blog.

Posted by Dragan at 9:48 AM 0 comments

ECEN 5807 POLICY

You may use this blog as a tool to post questions and comments related to Spring 2011 [ECEN5807](#) homework problems. However, simply posting your solutions or copying someone else's work is not allowed - all work you turn in must be your own. Absolutely no collaboration in any form is allowed on exams.

BLOG ARCHIVE

Power Electronics Program at CU Boulder

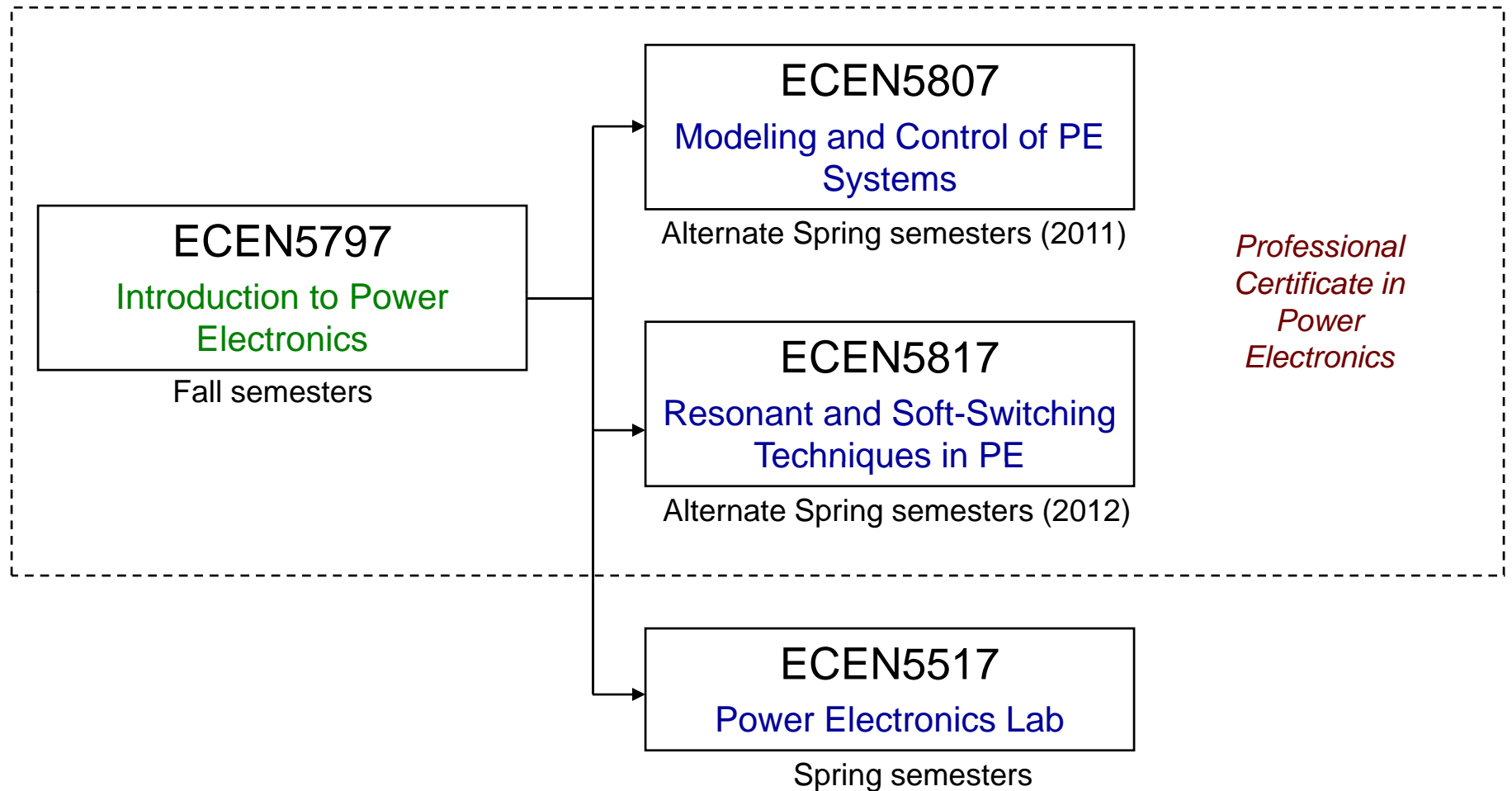

ECEN 5807 topics

1. Introduction to converter modeling and simulation using MATLAB/Simulink (notes)
2. Averaged-switch modeling and simulation (Section 7.4 and Appendix B)
3. Techniques of design-oriented analysis with switching converter applications
 - Middlebrook's extra-element and feedback theorem techniques (Appendix C and notes)
 - Input filter design (Chapter 10)
 - Writing complex converter transfer functions by inspection (notes)
 - Middlebrook's feedback theorem (notes)
4. Dynamic modeling of converters in discontinuous conduction mode
 - Averaged switch modeling (Chapter 11 and Appendix B)
 - Introduction to sampled-data modeling (notes)

ECEN 5807 topics

5. Current-mode control

- Averaged modeling of peak current-mode control (Chapter 12)
- More accurate models based on sampled-data modeling (notes)
- Averaged current-mode control (notes)

6. Modern rectifiers

- Power and harmonics in nonsinusoidal systems (Chapter 16)
- Pulse-width modulated low-harmonic (i.e. power-factor correction, or PFC) rectifiers (Chapter 18)
 - System modeling
 - Current control techniques
 - Voltage control techniques

7. Introduction to digital control of switch-mode power converters (notes)

- Digital realization of the basic control loop
- Discrete-time modeling
- Discrete-time compensator design examples