

# OPTICS LAB -ECEN 5606

Kelvin Wagner & Ben Braker

Experiment No. 4

## Linear Spectroscopy Techniques

February 15, 2018

### 1 Introduction

Spectroscopy, in most of its forms is the physical separation of light according to its wavelengths. This ability to quantify each resolvable portion of a spectrum and thereby characterize its source has been a very important tool in science and engineering; it has led to important discoveries in fields ranging from quantum mechanics to astronomy. In this experiment you will familiarize yourself with various spectrometers such as prisms, gratings, monochromators and scanning Fabry-Perot interferometers for spectrographic analysis, and you will learn when it is appropriate to use each of these instruments.

### 2 Background

The different frequency components of a light beam can be physically separated by exploiting properties or phenomenon which are wavelength dependent. Prisms exhibit different refractive indices to different wavelengths and hence refracts them at different angles. The location of the diffraction peaks from a grating changes with wavelength. A Fabry-Perot etalon resonates when its cavity length is an integral multiple of one half of the incident wavelength, so scanning the cavity length scans the resonant wavelength. Each of these wavelength- dependent properties may be used to build a spectrometer. In the following section you will be introduced to the spectrometers you will be using in this experiment.

#### 2.1 Prism spectrometer

A prism acts as a spectrometer by exploiting the wavelength dependence of refractive index. A polychromatic beam of light is collimated so that all the frequency components have the same angle of incidence on the prism. At the input air-glass interface of the prism (and at the output glass-air interface) each frequency of the beam sees a slightly different refractive index due to material dispersion and hence by Snell's law is refracted at a slightly different angle with respect to the prism surface normal. If both interfaces of the prism were parallel, this angular separation within the glass would be exactly compensated by the output interface. A prism, therefore has a wedge configuration such that the output glass-air interface further spreads the angular spectra. The light output by a prism is thus separated across different angles corresponding to the different wavelength components.

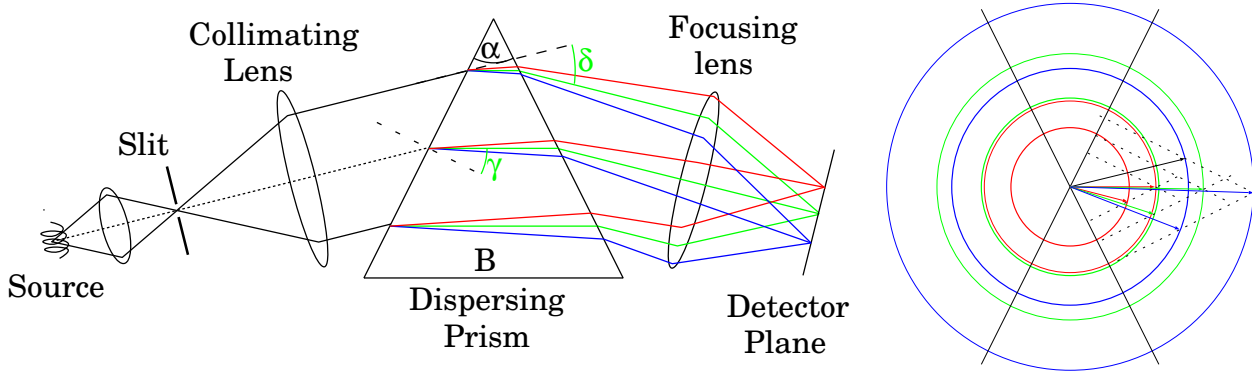

Figure 1: A simple prism spectrograph. The source is imaged onto a narrow slit and the emerging light is collimated by a lens. The refracted beams, emerging at different angles are focused by a second lens to give separate monochromatic images of the slit.

Fig. (1) shows the setup for a simple prism spectrograph. The light source illuminates a narrow slit and, an achromatic lens placed a focal length away from the slit collimates this beam to provide near perfect plane waves. This allows the beam of light to be incident across the entire face of the prism at a constant angle of incidence, so that the refraction angle is the same for all rays of a given color. The prism output is then focused onto an observation screen as shown. Since each color is incident on this lens at a different angle, each color is focused to a unique location in the focal plane of the lens, forming different monochromatic images of the slit.

The ultimate resolution limit of any spectrometer (assuming a sufficiently narrow slit) is determined by the spatial dispersion of its elements. If we assume all of the lenses in the system are larger than the prism face, then the resolution is determined by the size of prism. In spectroscopy the resolving power is determined as the ratio of the wavelength being observed to the smallest wavelength difference that can be resolved. The resolving power  $R$  of a prism is given by

$$R = \frac{\lambda}{\Delta\lambda} = w \frac{\sin \alpha}{\cos \gamma \cos \delta} \frac{dn}{d\lambda}, \quad (1)$$

where  $w$  is the beam width,  $\alpha$  the apex angle of the prism,  $\delta$  is the total deviation angle and  $\gamma$  is the angle of refraction at the first interface. It can be shown that at the angle of minimum deviation (when the input beam refracts parallel to the base B) then the geometrical factor is equal to the length of the base of the prism B in the direction of propagation. Hence the prism resolving power can be increased by using a larger prism (and larger lenses, if necessary).

## 2.2 Diffraction grating spectrometer

A grating illuminated by a beam of light can be thought of as an array of point sources re-radiating the incident illumination. Light from these secondary sources interfere and the angle of constructive interference is wavelength-dependent. This phenomena can be exploited to make a spectrometer, i.e. to separate a polychromatic light beam into its different frequency components. The condition for constructive interference is given by the grating equation:

$$m\lambda = d(\sin \theta_d \pm \sin \theta_i) \quad (2)$$

where  $\lambda$  is the wavelength,  $m$  is the diffracted order,  $d$  is the grating period spacing,  $\theta_d$  is the diffraction angle, and  $\theta_i$  is the incident angle. It states that, for two beams to interfere constructively, the difference between their path lengths must be an integral multiple of the wavelength.

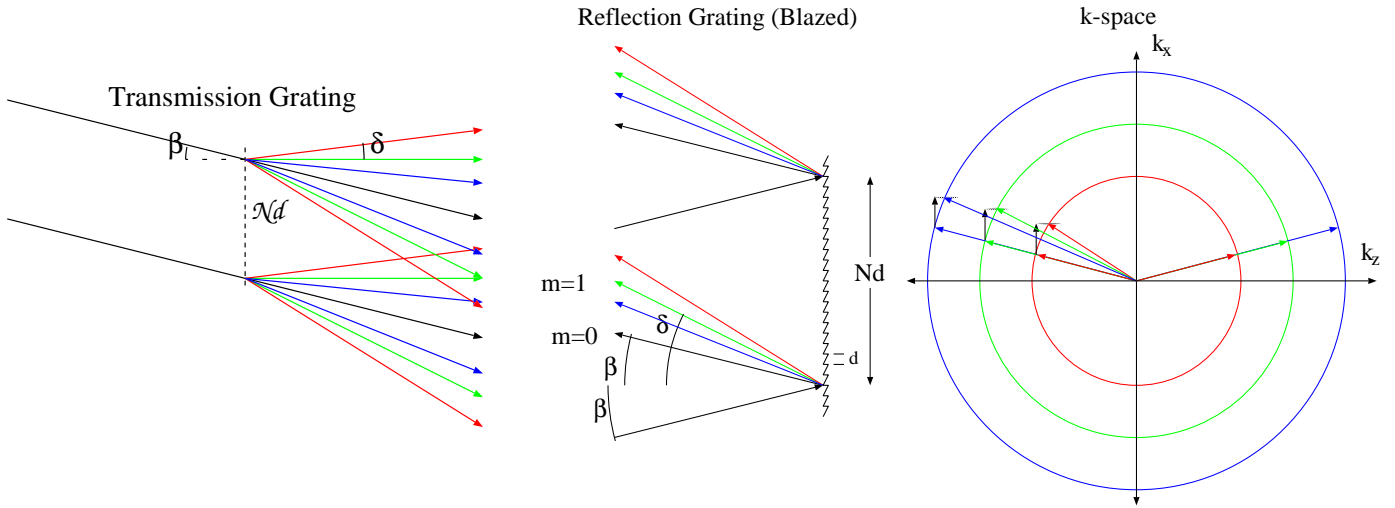

Figure 2: Geometry for determining the resolving power of a grating. The effective width of the grating is  $Nd \cos \delta_1$ , where the width of the grating is  $Nd$ . ( $N$ , the number of grating lines, and  $d$ , their separation.)

A grating for a spectrometer is usually a series of finely spaced grooves on a glass substrate. In many instances, the surface is metallized to produce a reflection grating. Diffraction gratings can also be created by holographic techniques.

The resolution limit of a grating spectrometer, as in the case of the prism spectrometer can be related to the width of the diffracted beam. In the  $m$ th order, a beam diffracted at an angle  $\delta_m$  by a fully illuminated grating has a beam width of  $W = Nd \cos \delta_m$ . The width of the grating is given by  $Nd$ ,  $N$  being the number of periods and  $d$  the periodicity, as shown in Fig. (2). The diffraction angle can be expressed in terms of the beam width as  $\sin \delta = \lambda / Nd \cos \delta_m$ . The angular separation between two different wavelengths is  $\Delta \delta_m = (m/d \cos \delta_m) \Delta \lambda$ . Solving for the resolving power  $R$ , we obtain

$$R = \frac{\lambda}{\Delta \lambda} = Nm$$

Thus only the total number of grooves in the illuminated portion of the grating and the order of the diffraction determines the resolving power of the grating. Special blazed gratings that operate at a very high order, known as echelles, can be used to increase the resolution.

## 2.3 Monochromator

Monochromators are devices which transmit a narrow band of wavelengths about a given central wavelength. By varying the central wavelength they can be used as a scanning device to scan and analyze any spectrum. Diffraction gratings driven by a sine bar drive are often used to vary the central wavelength. Fig. (3) and Fig. (5) help understand the operation of a monochromator. The input and the output slit positions are fixed and hence the angle  $\gamma$  between the input and output beam is a constant. A lens or concave mirror collimates light from the input slit and directs it onto the grating. The grating diffracts the incident light into various angular spectral components, which are again collimated and reflected towards the output slit. As the grating is rotated, only the wavelengths satisfying the grating equation (and the rotator equation given in Pre-Lab question #4) pass through the output slit. The remainder of the light is scattered and absorbed inside the monochromator.

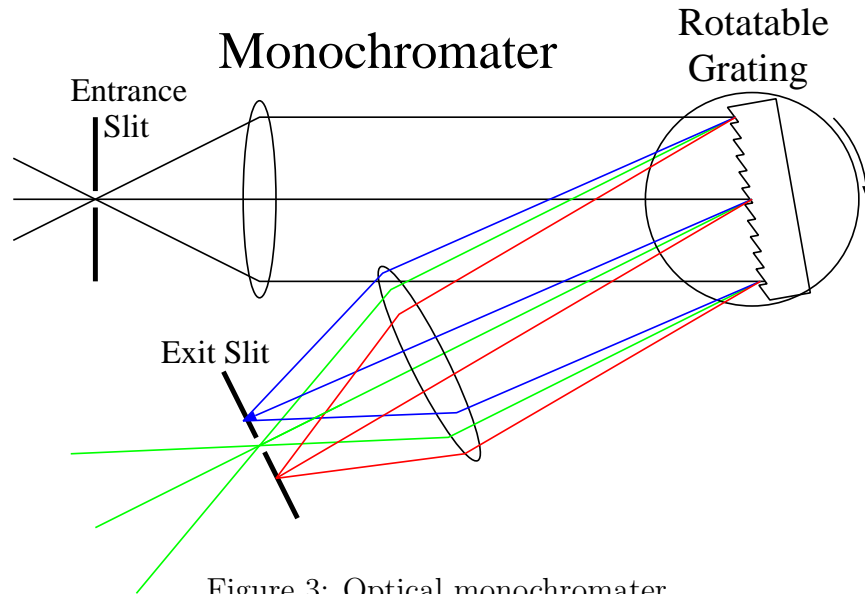

Figure 3: Optical monochromator

The monochromator design concentrates on the path of light from the input slit, off the grating and to the output slit. It is important to note the significance of  $m$ . in the grating equation. If some wavelength  $\lambda$  satisfies the grating equation it passes through in the slit as the first order, ( $m = 1$ ). However, the equation is also satisfied by  $(\lambda/2)$  for  $m = 2$ ,  $(\lambda/3)$  for  $m = 3$ , etc. Usually only the first order is desired and hence for accurate measurements, order sorting or blocking filters may be used to block the secondary wavelengths.

The monochromator input and output slits are chosen depending on the application it is used for. The slits can determine the throughput and the resolution of the device; a wide slit means a large bandpass. Hence a narrow slit is chosen when it is used as a source monochromator and a wide slit is used when it is used as a spectrum analyzer.

## 2.4 Fabry-Perot spectrometer

A Fabry-Perot spectrometer is an optical instrument that can be used as a variable band-pass filter or a spectrometer. It consists of two highly reflective, parallel mirrors separated by a distance,  $d$  (Fig. (4)). This arrangement forms a resonant optical cavity that transmits specific frequencies and rejects all the rest. The condition for resonance is that the mirror separation be an integral number of half wavelengths. The transmission of such a filter is shown in Fig. (4) . The frequency difference between adjacent transmission bands can be shown to be

$$\delta\nu = \frac{c}{2d}$$

where  $c =$  speed of light.

Even though this filter is designed to transmit about a particular wavelength, it is possible to “tune” a filter by tilting it with respect to the direction of incident light. The center of the pass band can be shifted to shorter wavelengths: from  $\lambda_0$  to  $\lambda' = \lambda_0 \cos \theta$  where  $\theta$  is the angle between the filter normal and the direction of light propagation. Although this procedure is convenient for small tilts, there is a considerable reflection loss at higher angles of incidence.

The resolution of a Fabry-Perot etalon is measured in terms of its Finesse  $\mathcal{F}$ , defined as the ratio of the separation between the transmission peaks to the half power width of each peak. Hence, the smaller the peak width and the smaller the mirror separation, the greater the resolution. In the absence of any other limits the mirror finesse is given by  $\mathcal{F} = \pi\sqrt{R}/(1 - R)$ , but this is

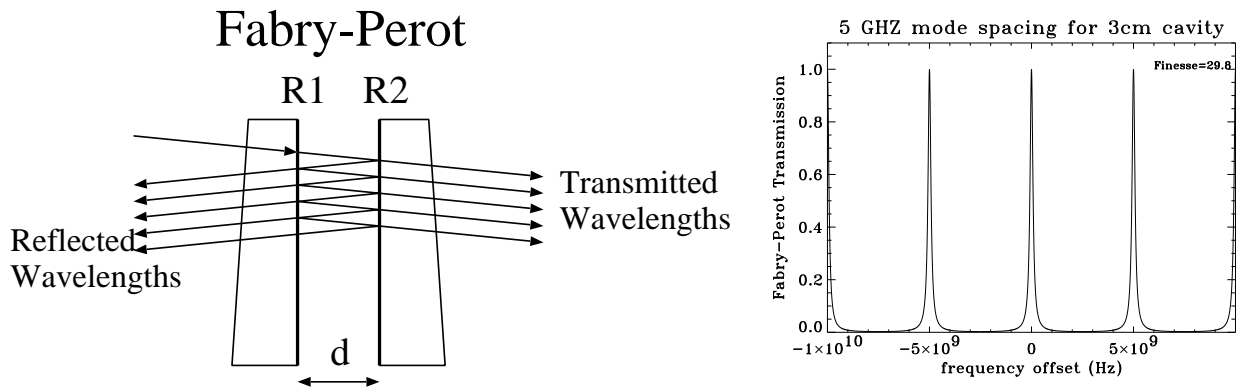

Figure 4: Fabry-Perot filter. (a) Consists of resonant cavity made by two highly reflective mirrors M1 and M2 separated by a distance  $d$  and aligned parallel to each other. (b) Transmission of light through a Fabry-Perot filter. The transmission occurs at frequencies spaced  $c/2d$  apart.

further limited by mirror flatness, detector size, pinhole size, and patience in alignment. The finesse-limited full-width-half-max ( $FSR/\mathcal{F}$ ) becomes  $FWHM = \frac{c(1-R)}{2\pi d\sqrt{R}}$ .

## 2.5 Equipment

- CUDA fiber-optic white light source
- Achromatic lens
- Diffraction grating
- ORIEL monochromator Model-77250
- Visible or Infra-red laser diode
- Spatial filter
- Collimating lens
- Additive & Subtractive color filters
- Burleigh Fabry-Perot interferometer
- Variable slit
- Prism mounted on rotating platform
- Optical Power meter (Newport or Thorlabs)
- interference filters
- Helium-Neon laser
- Iris
- Digital oscilloscope
- CCD camera
- Beamsplitter
- Translation stage

## 3 Preparation

Review the theory of gratings and prisms as dispersing elements, the operation of spectrometers and monochromators, and the theory of the scanning Fabry-Perot interferometer. Some suggestions are:

- Kingslake; Optical Systems Design; 16
- O'Shea; Modern Optical Design; 9
- Williams & Becklund; Optics; 10
- Klein; Optics; 5.6, 7.2, 7.3
- Nussbaum & Phillips; Contemporary Optics; 7
- Smith & Thompson; Optics; 14.7-15.4
- Pedrotti & Pedrotti; Introduction to Optics; 6, 11.6-11.9, 17

In addition you should read the monochromator description in the Oriel Catalog Vol. II and the Burleigh Fabry-Perot Interferometer Technical Memo and Instruction Manual. Bold letters indicate "highly recommended to be read before lab".

### 3.1 Prelab

1. Derive the condition for minimum deviation in a prism spectrometer. What is the relationship between the apex angle  $\alpha$  of the prism and the refraction angle  $\gamma$  (internal angle of refraction at the first prism interface) when the minimum deviation condition is satisfied? What is the resolving power of a prism with a base of length  $B$ , when the prism is aligned for minimum deviation ?
2. Derive the grating equation shown in Sec. (2.2) and the angular dispersion  $d\theta/d\lambda$  of a grating (mrad/nm). At what diffraction angle does the dispersion become linear (eg plot of  $\theta_d$  vs  $\lambda$ ), and what is the value of this dispersion? Show that the resolving power  $R = \lambda/\Delta\lambda$  of the grating is always less than  $2W/\lambda$  where  $W$  is the grating width. How does the resolving power of a grating compare to the resolving power of a prism of similar size.
3. Derive the free spectral range of a plane scanning Fabry-Perot interferometer and plot as a function of plate separation. Mirrors with 97.5% reflectivity and flatness of  $\lambda/100$  are used at separation of 1 mm and 10 cm. What are the Finesse limited FWHM resolution (in Hz) and free spectral ranges (in Hz) at these two plate separations?
4. [OPTIONAL] A spectrum can be scanned using a monochromator which uses a sine bar grating rotator as shown in Figure 5. The rotator equation is

$$\lambda = 2d \sin \theta \cos(\gamma/2)$$

where  $\lambda$  is the wavelength,  $d$  is the grating spacing,  $\gamma$  is the angle between input and output slits, and  $\theta$  is the angle by which the grating is rotated from the position when the zero'th order passes through the output slit. Derive the rotator equation and show that a constant rotation rate of the screw gives a linear change of the output wavelength with time.

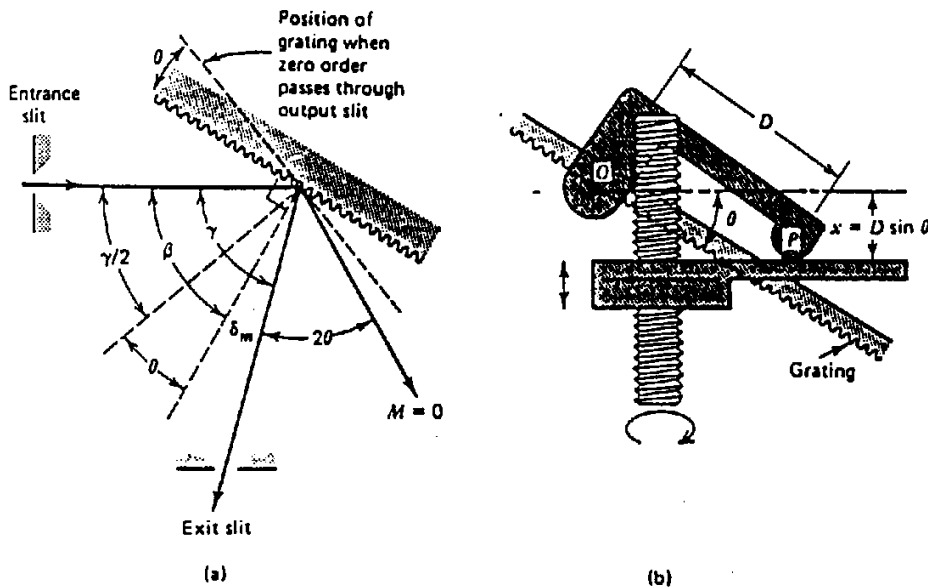

Figure 5: The sine bar drive. (a) Input and output beam geometry, (b) drive mechanism. This linkage changes the linear motion of the nut  $N$  on the screw into a circular motion of the grating so that the nut position is equal to the sine of the grating angle.  $O$  is the rotation point of the grating,  $P$  is the point where the linkage touches the nut on the screw and  $D$  is the distance between the two points.

## 4 Procedure (60 Pts.)

Note that Part 8, the Fabry-Perot interferometer is lengthy. So give yourself plenty of time for that section. For large groups, one member may want to work separately to set up part 7 while the others set up parts 1-6. Run all of the experiments together, however, since you will all need to take and analyze the data.

NOTE: Neatness counts! It will be an additional 10 Pts. in this lab.

### 1. Prism Spectrometer: (10 Pts.)

- (a) (1 Pt.) Set up the white light source to illuminate a vertical slit and get as much light as possible through the slit. Collimate the light passed by the slit with an achromatic lens as best as you can.

**Q:** Which direction, parallel or perpendicular to the slit, is easier to collimate, and why?

- (b) (1 Pt.) Place the prism on its rotating platform in the path of the collimated beam and observe the chromatically dispersed spectrum. Rotate the prism to the symmetric minimum deviation angle for yellow light ( $\lambda \approx 550$  nm).

**D:** Measure this angle.

- (c) (3 Pts.) Focus the dispersed light onto a card with a long focal length lens and measure the spectral width. Assume it is perfect white light source.

**D:** Estimate the dispersion  $d\theta/d\lambda$  in mrad/nm.

**Q:** What is the resolution achievable with this prism?

**Q:** What limits the resolution of this spectrometer, the input slit or the prism dispersive power?

- (d) **Subtractive color filters.** (2 Pts.) Insert the three subtractive color filters blocks (Yellow, Magenta, and Cyan) one by one in the beam path (try the different lengths).

**D:** Describe the spectrum, including estimates of the center wavelength, bandwidth, etc.

**D:** Now insert pairs of subtractive color filters in series and describe the resulting spectrum for each pair.

- (e) **Additive color filters.** (3 Pts.) In comparison, insert the three additive dielectric color filters (Red, Green, Blue) one by one.

**D:** Describe the spectrum, including estimates of the center wavelength, bandwidth, etc.

**Q:** What happens when you insert pairs of additive filters in series along the beam path?

**Q:** What is the difference between additive and subtractive color filters?

### 2. Grating spectrometer: (5 Pts.)

- (a) (1 Pt.) Replace the prism with a grating. Rotate to find the angle where the dispersion is linear with respect to wavelength, as found in Pre-Lab question #2. Is this the brightest order at this angle?

**Q:** What is this angle?

(b) *4 Pts.* Focus the output spectrum onto a card with a lens.

**Q:** What is the spectral width?

**Q:** What is the dispersion  $d\theta/d\lambda$  in mrad/nm?

**Q:** What is the resolution power of this grating when it is fully illuminated?

3. **[EXTRA CREDIT] Spectral filtering: (5 Pts.)**

(a) *(2 Pts.)* Place a mirror (or mirrors) in the plane where the card was; the spots should now focus on the mirror. Insert a beamsplitter between the white light source slit and the achromatic lens. Adjust the mirror (or mirrors) such that the reflected light falls back along the input light.

**Q:** What color is the reflected light?

**Q:** What is the relative power of the reflected light compared to the input light?

(b) *(3 Pts.)* Place a mask cut out of black paper just in front of the mirror (or mirrors) and pass specific segments of the spectrum. Now, make a mask with a small slit that passes a small segment of the spectrum.

**D:** Shift this spectral mask across the spatially-diffracted-spectrum on the mirror in at least 10 evenly spaced increments and measure the power at each segment.

**D:** Plot the spectrum of the source. What are the correct units on your y-axis?

4. **Characterizing a laser diode with a grating spectrometer: (5 Pts.)**

(a) *(1 Pt.)* Collimate the visible laser diode so that you can illuminate a grating.

**Q:** To obtain high resolution, should the elliptical-beam major axis be in the plane of dispersion or orthogonal to it?

(b) *(1 Pt.)* Describe the polarization dependence of the diffraction efficiency. This can be studied by placing a half-wave plate (HWP) between the laser diode and the spectrometer.

**D:** Rotate the HWP and measure the diffraction efficiency.

(c) *(3 Pts.)* Fourier transform the diffracted laser diode spectrum onto a CCD detector array, and display the spectrum on the monitor and an oscilloscope.

**D:** Measure and plot the spectrum of the laser below and above threshold.

**Q:** Can you resolve the mode structure? If yes, what is the mode separation?

**D:** Does the visible laser diode become single mode as you go up to 2-3 mW output power?

**D:** What happens as you change the temperature using the laser diode temperature controller?



## 5. Monochromator: (8 Pts.)

- (a) (6 Pts.) Focus the collimated beam and illuminate the input slit of the monochromator with the focused spot. You may need to narrow the source slit and adjust your imaging optics to form a tight spot through the monochromator input slit. Leave the source slit size as it is from now on. Using an iris, cut the beam size to about 2mm diameter. This will help you in getting more measurements in Part 6. Turn the monochromator knob to '000' and verify the light re-emerges from the output slit.

**D:** Open up the monochromator & describe how it works.

**D:** By carefully inspecting the optical path, determine how much of the grating is illuminated.

**Q:** For a 1200 lines/mm grating what is the best possible resolution you could expect from this instrument?

**Q:** Why is it only specified to .5 nm resolution, at best?

- (b) (2 Pts.) Now, insert an optical bandpass filter in the collimated beam and place the power meter immediately next to the output slit. Cover the monochromator and the power meter with dark cloth and seal all light leaks.

**D:** By adjusting the monochromator dial and measuring the power level as you change the dial, find the center wavelength and the passband of the spectral filter.

## 6. Measuring the spectrum of the white light source: (2 Pts.)

- (a) Now couple the white light into a multi-mode fiber if an appropriate fiber jumper is available, otherwise just focus directly into the spectrometer entrance port. The fiber core is around 50  $\mu\text{m}$ , so use a short focal length lens to re-image as much light into the fiber core as you can. Use a power meter at the other side of the fiber once you've gotten the fiber relatively close to the light. Maximize the coupled light by tweaking the position (x,y,z) and angle (yaw and elevation) of the fiber.

- (b) Once you have enough light coupled into the fiber, move the output fiber from the power meter to the spectrum analyzer.

- i. Double click on the BWspec executable on the desktop
- ii. To start collecting data go to the "Acquire" drop down menu and select "Acquire Continuously" - See first screen shot
- iii. You should now see a spectrum of the source. - (See second screen shot) Adjust the power of the light source to ensure there is no saturation. Alignment is a bit touchy when doing free space coupling so take time to ensure that the alignment is good, or use a multimode fiber patch cord

**D:** Plot and save the reference spectrum of the white light source from 400 to 1000 nm. This is your reference spectra to be used for normalization purposes in part 6.

## 7. Characterizing an interference filter using the spectrum Analyzer: (15 Pts.)

- (a) (3 Pts.) Place the bandpass filter in the path of the collimated beam.

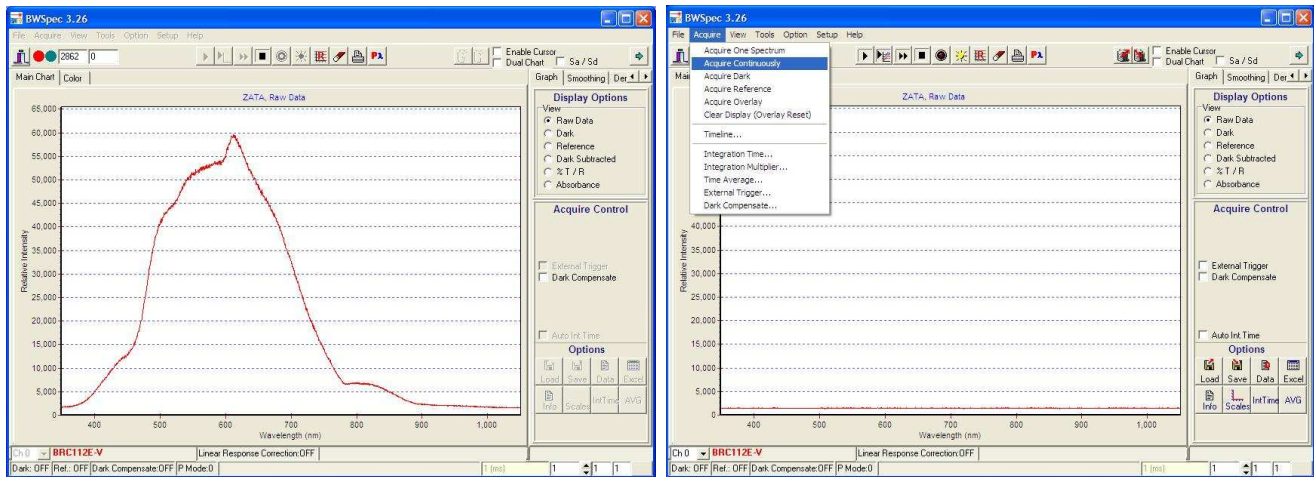

Figure 6: Control panel of the BWTEK Econic fiber coupled PC based grating spectrometer. Note that the software works on only one USB port of the PC, so if it requests an Admin login you must try a different USB port. After launching the software choose continuous acquisition. You can divide a measured spectrum by the reference spectrum in the Econic software.

**D:** Measure the transmission spectrum of this filter.

**Q:** What is the peak transmission amplitude and wavelength (you will have to normalize using your calibration spectrum)?

**Q:** What is the Full Width at Half Maximum (FWHM) bandwidth?

(b) (12 Pts.) Now tilt the bandpass filter through a few 15 degree increments, measuring the peak transmission amplitude and the FWHM at each angle. As you tilt it, make sure some of the full beam is incident on the interference filter. You DO NOT need to measure the full spectrum, just find the peak and the half-power points.

**D:** Plot peak transmission and FWHM as a function of rotation angle.

**Q:** Does tilting the filter tune it towards longer or shorter wavelengths? Why?

**Q:** What are the extremes of wavelength tunability?

**Q:** What does all this tell you about using interference filters in convergent light?

**D:** Try it and describe your results. (Hint-use a very aggressive lens.)

## 8. Fabry-Perot interferometer: (15 Pts.)

(a) (3 Pts.) Spatial filter and collimate the unpolarized HeNe laser, and center an iris on the output beam. Use this as the alignment beam and follow the procedure in Section 4 of the Burleigh Fabry-Perot instruction manual to align the interferometer. Keep the mirrors about 3 cm apart, to yield a FSR of about 5 GHz.

**D:** When you have a tiny wedge in the mirrors, you should see the laser spectrum over a few FSR displayed in space. Describe this.

(b) (2 Pts.) Use a lens to focus the output light onto a small detector or use a larger detector with a pinhole in front of it.

- D:** Calculate the limit of the finesse based on the pinhole diameter and make sure that this is not the limiting factor in your resolution by comparing with Pre-Lab Problem #3.
- (c) (*10 Pts.*) Read the RC-44 ramp generator instruction manual, and have your TA help you turn the Fabry-Perot into scanning mode. Examine the repeating ramp (or sawtooth wave) and the detector signal simultaneously on an oscilloscope. Vary the bias of the ramp systematically until you find the HeNe modes; these should appear as a series of distinct peaks in the detector output. Beware: poor finesse may result in a broad peak. Adjust the ramp parameters so that you scan over 1 FSR.
- Q:** What is the Finesse of your Fabry-Perot interferometer?
- D:** Resolve the modes of the HeNe and discuss your observations.
- D:** Estimate the length of the resonant cavity of the HeNe laser from the mode separation you have just measured.
- Q:** How many modes are contained within the gain profile, and what is the width of the gain profile?
- Q:** Are there any signs of thermal drift of the modes under the HeNe gain profile?
- D:** Now place a polarizer in front of the unpolarized HeNe and rotate it, describe your observations, and discuss what an unpolarized HeNe is.
- D:** OPTIONAL: Add magnets to the side of the HeNe and again rotate the polarizer. Does this affect the polarization of the modes?
- D:** Now Switch to the polarized HeNe by moving the kinematic mirror mount to its pick off location, but tweaking no other alignment. Hopefully you can still see modes. Is the mode spacing the same or different?